

EMI Power Filters

find the ideal method to filter the AC or DC power entering your system to prevent radiated or conducted EMI with our line of standard power filters and custom power solutions



Power Entry Modules, Power Line & 3 Phase Power Filters are designed in multiple configurations to cover a range of industrial applications. These have excellent attenuation for high voltage impulse, are available in single and dual stage and address FCC Part 15 regulations while meeting your power filtering needs... **PF5-PF6 & PF16-PF89**



Single Line Feed-Through (SLFT) Power Filters provide superior filtering in a compact, durable package with single, dual, and triple feed-throughs available. These filters are ideal for meeting broad frequency applications with a bolt-in style for easy installation... **PF7-PF14**



Military/Aerospace Multisection Filters provide excellent EMI filtering for demanding high reliability applications. We offer standard filters, as well as custom designed mechanical packages for unusual or tight fitting spaces and higher performance filtering and expanded voltage ratings... **PF91-PF98**



EMI Power Filter Solutions will lower your costs and reduce your time to market while providing your system with protection from radiated or conducted EMI. Our comprehensive consulting, diagnostic testing and world class manufacturing allows us to meet your design/project parameters... **PF99**



EMI Filter Expertise

We differentiate ourselves from typical filter suppliers by offering our customers an integrated approach to EMC problem solving through consulting, diagnostic testing, design and manufacturing.

- In-house test facilities to provide a total solution for your compliance issues – anechoic chamber, shielded room and NARTE certified engineers ready to test for European emission and immunity regulations, FCC Part 15 and MIL standards

- Global manufacturing and design support with agency approved products available
- Engineering expertise and vertical integration reduce your time to market and save you money
- High reliability products with low leakage and nonmagnetic options available
- Available to meet MIL-PRF-15733 and MIL-STD-461 standards

Application Guidelines

Need for EMI suppression

Global regulatory agencies have established limits to the amount of noise that man-made electronic devices can radiate or conduct. These regulations have gained greater importance as the world's electronic population intensifies and the proximity of electronic devices becomes closer.

EMI can propagate through two basic avenues: Conducted and Radiated

Conducted refers to events where the EMI energy flowthrough power lines, data cables and other wiring that carries functional data or power.

Radiated refers to energy that is propagated by magnetic or electric fields, which originate from other electronic or electrical systems.

Interference types

There are two modes of conducted noise: differential mode (symmetrical or normal mode) and common mode (asymmetrical mode).

Differential mode interference signals are present on one side of the line, referenced to the other. The currents flow along one phase and return along another phase.

Common mode interference signals are present on both sides of the line referenced to ground. The current flows from the source to ground along the ground path and returns along the phases.

Sources of EMI

Electromagnetic interference can occur naturally or through electronic sources. Lightning discharges, precipitation, sand and dust storms, and cosmic noise are sources of natural EMI.

EMI generated from power electrical products cause the most concern. These man-made sources, such as power lines, rotating machinery, power supplies and electronic transmission devices, all have their own signatures and noise pollution.

EMI filters, insertion loss and attenuation

Power line EMI filters are designed to attenuate (or reduce) all radio frequency emissions or energy that is above the applicable EMC specification. Most power line EMI filters utilize inductor/capacitor "low pass" component configurations that pass all DC or low frequency AC necessary energy and attenuate (suppress) higher frequencies containing noise or unwanted energy.



Power Filter Installation

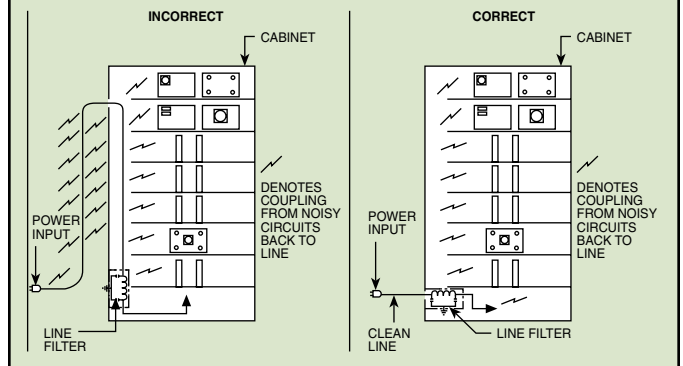

To insure a customer's "in system" unit to unit attenuation uniformity of power line filters, an insertion loss production line test is performed by API Technologies.

Each of the specific frequencies is measured using RF test equipment and the "reference signal level" of each frequency is stored. Some systems sweep the entire frequency range and store this "reference signal level". The filter to be measured, tested, or evaluated is then "inserted" between the generator and receiver that established the stored "reference signal level" on the RF test analyzer.

The measured difference without a filter ("the reference signal level") and with the filter "inserted" into the RF test equipment/analyzer is defined as insertion loss. The unit of measure for insertion loss is the decibel (dB). As noted on most curves in this bulletin, as frequency increases, the higher the insertion loss or dB value. The plot of frequency versus dB value establishes the typical insertion loss curve.

Installation Criteria

Proper installation of a filter network is critical to achieving successful filtering of electromagnetic interference. API recommends that power line filters be installed where the power line enters the equipment. The filter acts as a barrier between polluted energy and clean energy going into your equipment. It is important that the filter is connected to an effective ground plane and where proximity does not couple radiated noise to the clean lines.

Measurement Guidelines

API Technologies has the capability to perform a wide range of tests for EMI filters. Unique custom testing systems designed by Spectrum assure the accuracy required in today's demanding environments. Testing is performed by employing a 50 ohm source and load impedance per MIL-STD-220. The individual filter performance is stated in terms of insertion loss. Overall attenuation reflects the filter's interaction within the system. Individual filter performance may differ from system to system and each application should be verified through system testing. Examples of various testing abilities and configurations are outlined below.

Differential (Normal or Symmetrical) Mode Insertion Loss

Differential mode noise is caused by non-sinusoidal conduction of rectifiers and other switching devices creating harmonic distortion.

This noise is predominant from the power frequency to approximately 10 MHz. Since it follows conventional current flow, it is considered to be of the same magnitude but opposite phase of the other line. Spectrum measures differential mode insertion loss in a 50 ohm system with Balun transformers as shown.

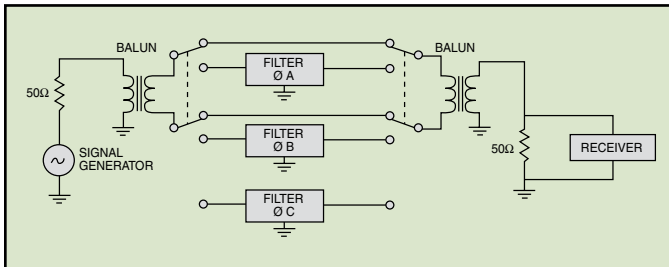

Common (Asymmetrical) Mode Insertion Loss

Since common mode insertion loss is of the same phase as the opposite line, they may not be of the same magnitude, depending on the end system circuitry. Spectrum Control tests common mode insertion loss on each line in a 50 ohm system as shown.

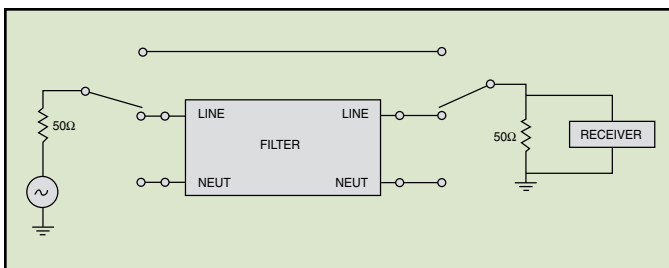

Leakage Current

Leakage is a measurement of reactive current (capacitance) to ground per line. Spectrum uses the following test setup for leakage current measurement.

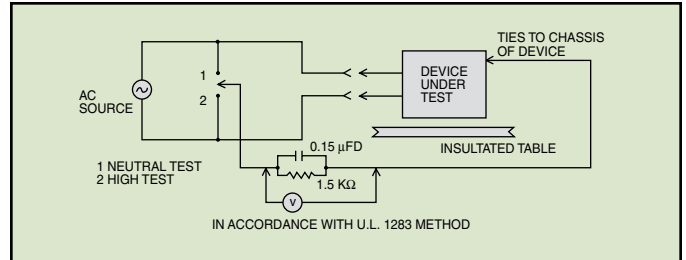

AC Voltage Drop

AC voltage drop is defined as $E_{in} - E_{out} = AC$ voltage drop.

Spectrum Control uses the following circuit for AC voltage drop testing:

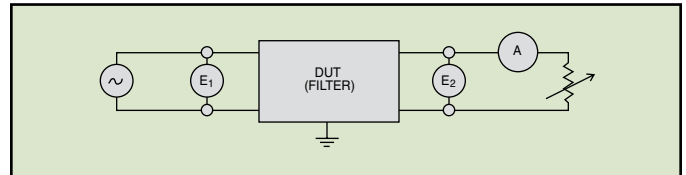

DC Voltage Drop

DC voltage drop is performed on each line individually. This test provides the total DC voltage drop for that line of the filter. The following circuit is used in testing:

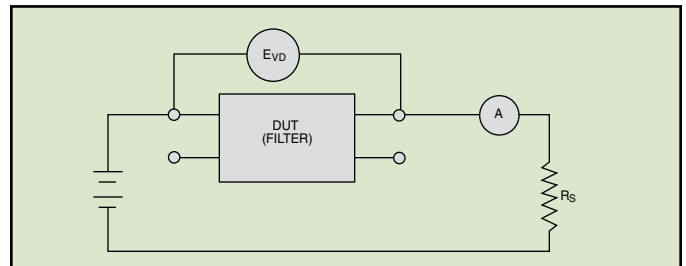

Power Entry Modules, Power Line Filters & 3 Phase Power Filters Part Numbering System

Part Numbering System

Example: **12-PMB-025-5-A**

Part number 12-PMB-025-5A represents a power line filter with threaded studs, current rated for 25 Amps and with a leakage current of 0.50 mA.

12	-	PMB	-	025	-	5	-	A
<p>Product Line Series</p> <p>10 = Filtered IEC Inlets 11 = Printed Circuit Board Mount 12 = Power Line Filters 13 = Three Phase Power Line Filters 14 = Fused or Switched & Fused Power Entry Filters (250V) 15 = Switched & Dual Fused 16 = Single Phase (250V)</p>		<p>Product Style</p> <p>BBF = 3 Phase, terminal block connection BFF = Bolt-in fused filter BPF = Bolt-in IEC w/Fast-on rear terminals BPL = Bolt-in IEC w/wire lead termination BSF = Bolt-in switched & fused CCL = Cylindrical, capacitive inputs w/Fast-ons CLF = Cylindrical, inductive inputs w/wire leads MMB = Multiple stage filtering w/threading studs MMF = Multiple stage filtering w/Fast-on terminal MPC = Miniature PCB mountable PDB = 3 Phase, delta w/threaded studs PDF = 3 Phase, delta w/Fast-ons PDL = 3 Phase, delta w/wire leads PMB = Power line filter w/threaded studs PMF = Power line filter w/Fast-ons PML = Power line filter w/wire leads PWB = 3 Phase, wye w/threaded studs PWE = 3 Phase, wye w/busbar PWF = 3 Phase, wye w/Fast-ons PWL = 3 Phase, wye w/wire leads</p>		<p>Current Rating</p> <p>001 = 1.0 Amp 002 = 2.0 Amps 003 = 3.0 Amps 005 = 5.0 Amps 006 = 6.0 Amps 010 = 10 Amps 015 = 15 Amps 016 = 16 Amps 020 = 20 Amps 025 = 25 Amps 030 = 30 Amps 035 = 35 Amps 050 = 50 Amps 080 = 80 Amps 100 = 100 Amps 150 = 150 Amps 160 = 16.0 Amps 200 = 200 Amps 300 = 300 Amps 400 = 400 Amps 500 = 500 Amps 600 = 600 Amps</p>		<p>Leakage Current (Y Cap)</p> <p>250 VAC 125VAC 0 = 0.075 mA DC = DC 1 = 0.01 mA 2 = 0.20 mA 3 = 0.35 mA 4 = 0.10mA 5 = 0.50 mA 6 = 0.60 mA 7 = 0.70 mA 8 = 1.0 mA 9 = 3.0 mA 10 = 2.0 mA 11 = 1.5 mA 12 = 4.5 mA 13 = 9.0 mA 14 = 20.0 mA 15 = 15.0 mA 17 = 33.0 mA 18 = 71.5 mA DC = DC</p>		<p>Outline Drawing/ Case Style</p> <p>1 Select case style from following * Cylindrical * Power line w/Fast-on * Power line w/threaded studs * Power line w/wire leads * PCB mount * Large case 3 Phase delta * Large case 3 Phase wye * IEC Inlet</p> <p>2 Refer to drawing list per selected case style</p> <p>3 Letter at the end of the part is found in the case style drawing list: A, B, C, D, E, F, etc.</p>

* Note: Not all series offer the product style, rating and leakage current

Power Entry Modules, Power Line Filters & 3 Phase Power Filters Part Numbering System

Part Numbering System

Example: **60-BPR-060-5-4**

Part number 60-BPR-060-5-4 represents a power entry module, bolt-in style with fast-on terminals, a current rating of 6 Amps, leakage current of 0.50 mA and capacitance of 0.047 μ F.

60	-	BPR	-	060	-	5	-	4
Product Line Series		Product Style		Current Rating		Leakage Current (Y Cap)		Capacitance (X Cap)
60 = Power Entry Modules		AFL = Appliance filter w/ inductive input		010 = 1.0 Amps		250 VAC		0 = none
61 = Mini PCB Power Filters		AFC = Appliance filter w/ capacitive input		015 = 1.5 Amps		0 = 0.075 mA		1 = 0.01 μ F
62 = Power Line Filters		ARL = AFL plus bleeder resistor		016 = 1.6 Amps		1 = 0.01 mA		2 = 0.022 μ F
63 = Three Phase Power Line Filters		BFF = Fused filter w/ Fast-on terminals		020 = 2.0 Amps		2 = 0.20 mA		3 = 0.033 μ F
64 = Fused or Switched & Fused Power Entry Filters (250V)		BFS = Fused filter w/solder lug terminals		030 = 3.0 Amps		3 = 0.35 mA		4 = 0.047 μ F
65 = Fused or Switched & Fused Power Entry Filters (125V)		BHP = High frequency bolt-in for PCB		040 = 4.0 Amps		4 = 0.10 mA		5 = 0.050 μ F
66 = Fused or Switched & Fused Low Leakage Power Entry Filters (250V)		BHS = High frequency bolt-in w/solder lugs		050 = 5.0 Amps		5 = 0.50 mA		6 = 0.068 μ F
67 = Fused or Switched & Fused Low Leakage Power Entry Filters (125V)		BPF = Bolt-In right angle terminals		060 = 6.0 Amps		6 = 0.60 mA		01 = 2 x 0.01 μ F
68 = Switched & Dual Fused Power Entry Filters		BPL = Bolt-in w/wire leads		080 = 8.0 Amps		7 = 0.70 mA		02 = 0.10 μ F & 0.22 μ F
69 = Dual Fused Only or Dual Switched Only Power Entry Filters		BPP = Bolt-in PCB mount		100 = 10.0 Amps		8 = 1.00 mA		04 = 2 x 0.22 μ F
		BPR = Bolt-in w/Fast-on tab terminals		150 = 15.0 Amps		9 = 3.00 mA		06 = 2 x 0.4 μ F & 0.22 μ F
		BPS = Bolt-in w/ solder lug terminals		160 = 16.0 Amps				10 = 0.15 μ F
		BSF = Bolt-in switched & fused		200 = 20.0 Amps				11 = 0.10 μ F
		MMF = Metal case w/fast-on tabs		300 = 30.0 Amps				12 = 0.22 μ F
		MPC = Miniature printed circuit board		400 = 40.0 Amps				13 = 0.33 μ F
		PMB = Metal case w/bolt-on terminals						14 = 0.47 μ F
		PMF = Metal case w/Fast-on tabs						16 = 0.22 μ F & 2 x 0.33 μ F
		PML = Metal case w/wire leads						21 = 1.00 μ F
		PPF = Plastic case w/Fast-on tabs						
		PQF = Plastic case w/Fast-on tabs						
		PRF = Plastic case w/Fast-on tabs						
		SOF = Switched filter w/ Fast-on tabs						
		SOS = Switched filter w/ solder tabs						
		SPL = Snap-in w/wire leads						
		SPR = Snap-in w/Fast-on terminals						
		SPS = Snap-in w/solder lug terminals						
		SSF = Snap-in switched & fused						
		ARC = AFC plus bleeder resistor						

* Note: Not all series offer the product style, rating and leakage current

High Current DC Single Line Feed-through Series



Features

- Voltage rating of 130VDC
- C configuration with Class Y4 capacitors
- Current rating up to 300 Amps
- Operating temperature range: -40°C to +85°C
- Excellent filtering in compact package
- Bolt-in style with D-shaped bushing for easy installation
- Low cost EMI solution
- Design flexibility
- UL and Semko approved

Applications

- Telecommunications (cellular base stations, telephone switching racks, etc.)
- Power supplies
- Medical equipment
- C.O.T.S. (Commercial-Off-The-Shelf) Military
- Industrial equipment controls
- Data transmission equipment

RoHS
COMPLIANT

Specifications

Part Number	Rated Current	Min. Cap.	Minimum Insertion Loss (db)*					
			.01MHz	.10MHz	1MHz	10MHz	100MHz	1000MHz
52F226-011-10	10A	10nF	-	-	4	21	41	60
52F226-011-16	16A							
52F226-011-32	32A							
52F226-011-63	63A							
52F226-011-100	100A	47nF	-	2	15	34	53	74
52F226-011-200	200A							
52F226-011-250	250A							
52F226-011-300	300A							
52F226-011-100	100A	100nF	-	5	21	40	60	85
52F226-011-250	250A							
52F226-011-300	300A							
52F226-011-100	100A							
52F226-021-16	16A	47nF	-	2	15	34	53	74
52F226-021-32	32A							
52F226-021-63	63A							
52F226-021-100	100A							
52F226-021-100	100A	100nF	2	16	33	52	75	90
52F226-021-200	200A							
52F226-021-250	250A							
52F226-021-300	300A							
52F226-031-16	16A	100nF	-	5	21	40	60	85
52F226-031-32	32A							
52F226-031-63	63A							
52F226-031-100	100A							
52F226-031-100	100A	470nF	2	16	33	52	75	90
52F226-031-200	200A							
52F226-031-250	250A							
52F226-031-300	300A							
52F226-041-16	16A	1000nF	6	20	40	60	85	90
52F226-041-32	32A							
52F226-041-63	63A							
52F226-041-100	100A							
52F226-041-100	100A	4700nF	15	35	54	74	90	90
52F226-041-200	200A							

* Optimum performance with proper installation

High Current DC Single Line Feed-through Series

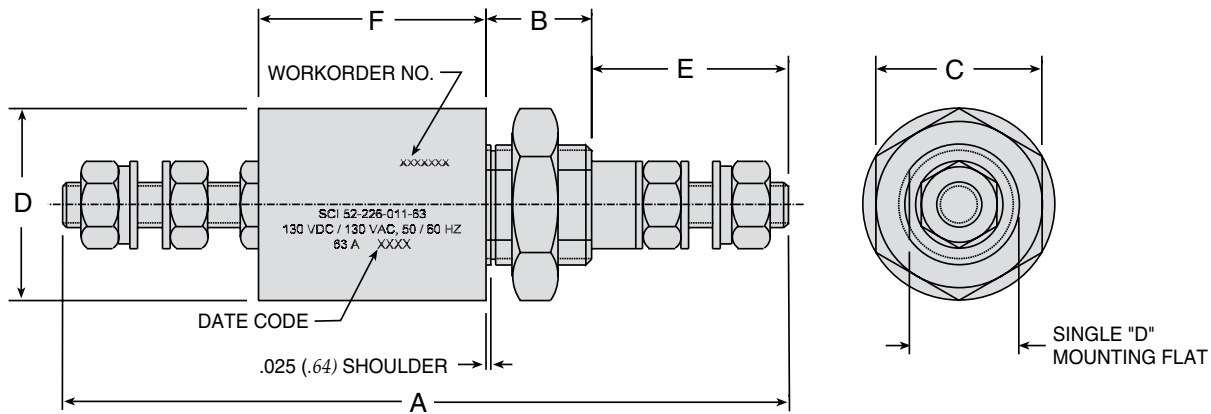

Dimensions

Part Number	A	B	C	D	E	F
52F226-011-10	2.24 (57)	0.39 (10)	0.51 (13)	0.56 (14.29)	0.63 (16)	0.71 (18)
52F226-011-16	2.48 (63)	0.47 (12)	0.67 (17)	0.75 (19.05)	0.71 (18)	
52F226-011-32						
52F226-011-63	3.78 (96)	0.55 (14)	0.87 (22)	1 (25.40)	1.02 (26)	1.18 (30)
52F226-011-100	4.45 (113)	0.63 (16)	1.06 (27)	1.25 (31.75)	1.26 (32)	1.30 (33)
52F226-011-200	5.12 (130)	0.75 (19)			1.57 (40)	
52F226-011-250	5.83 (148)		1.57 (40)	2 (50.80)	1.81 (46)	
52F226-011-300		6.30 (160)	1.57 (40)	2 (50.80)	1.81 (46)	1.65 (42)
52F226-021-16	2.95 (75)	0.47 (12)	0.67 (17)	0.75 (19.05)	0.71 (18)	1.18 (30)
52F226-021-32						
52F226-021-63	3.78 (96)	0.55 (14)	0.87 (22)	1 (25.40)	1.02 (26)	
52F226-021-100	4.45 (113)	0.63 (16)	1.06 (27)	1.25 (31.75)	1.26 (32)	1.30 (33)
52F226-021-200	5.12 (130)	0.75 (19)			1.57 (40)	
52F226-021-250	6.30 (160)		1.57 (40)	2 (50.80)	1.81 (46)	
52F226-021-300		6.30 (160)	1.57 (40)	2 (50.80)	1.81 (46)	2.13 (54)
52F226-031-16	2.95 (75)	0.47 (12)	0.67 (17)	0.75 (19.05)	0.71 (18)	1.18 (30)
52F226-031-32						
52F226-031-63	3.78 (96)	0.55 (14)	0.87 (22)	1 (25.40)	1.02 (26)	
52F226-031-100	4.45 (113)	0.63 (16)	1.06 (27)	1.25 (31.75)	1.26 (32)	1.30 (33)
52F226-031-200	5.79 (147)	0.75 (19)			1.5 (38.10)	
52F226-031-250	7.01 (178)		1.57 (40)	2 (50.80)	1.81 (46)	
52F226-031-300		7.01 (178)	1.57 (40)	2 (50.80)	1.81 (46)	2.83 (72)
52F226-041-16	3.23 (82)	0.63 (16)	1.06 (27)	1.25 (31.75)	0.71 (18)	1.30 (33)
52F226-041-32						
52F226-041-63	3.98 (101)	0.75 (19)	1.57 (40)	1.5 (38.10)	1.02 (26)	
52F226-041-100	5.24 (133)				1.26 (32)	1.97 (50)
52F226-041-200	6.50 (165)	0.75 (19)	1.57 (40)	2 (50.80)	1.57 (40)	2.68 (68)

Dimensions in inches (mm)

High Current DC Single Line Pi Series



RoHS
COMPLIANT

Features

- Voltage rating of 130VDC
- Pi configuration with Class Y4 capacitors
- Current rating up to 200 Amps
- Excellent filtering in compact package
- Bolt-in style with D-shaped bushing for easy installation
- Low cost EMI solution
- UL and Semko approved

Applications

- Telecommunications (cellular base stations, telephone switching racks, etc.)
- Power supplies
- Medical equipment
- C.O.T.S. (Commercial-Off-The-Shelf) Military
- Industrial equipment controls
- Data transmission equipment

Circuit Diagram

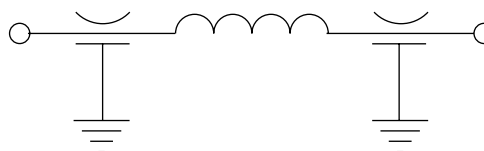

Specifications

Part Number	Rated Current	Min. Cap. (2X)	Minimum Insertion Loss (db) *					
			.01MHz	.10MHz	1MHz	10MHz	100MHz	1000MHz
Standard Performance								
52F226-020-10	10A	10nF	-	0.5	8	23	70	90
52F226-020-16	16A			35				
52F226-020-32	32A			2	10	23	50	
52F226-020-63	63A	100nF	8	27	67	90		
52F226-020-100	100A	470nF	4	21	70			
52F226-020-200	200A		7	23	30		60	
High Performance								
52F226-029-10	10A	100nF	-	8	25	75	90	90
52F226-029-16	16A							
52F226-029-32	32A							
52F226-029-63	63A	470nF	4	21	35	70		
52F226-029-100	100A	1000nF	8	26	57	73		
52F226-029-200	200A	4700nF	20	40	85	90		

* Optimum performance with proper installation

High Current DC Single Line Pi Series

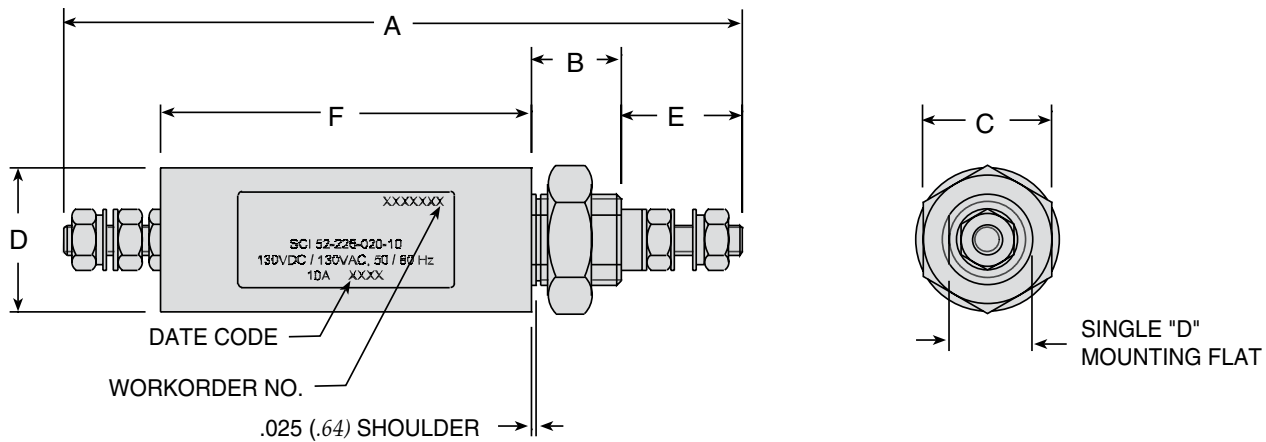

Dimensions

Part Number	A	B	C	D	E	F
Standard Performance						
52F226-020-10	3.54 (90)	0.47 (12)	0.67 (17)	0.75 (19.05)	0.63 (16)	1.93 (49)
52F226-020-16	3.86 (98)				0.71 (18)	2.09 (53)
52F226-020-32					1.02 (26)	3.70 (94)
52F226-020-63	6.30 (160)	0.55 (14)	0.87 (22)	1 (25.40)	1.26 (32)	4.09 (104)
52F226-020-100	7.24 (184)	0.63 (16)	1.06 (27)	1.25 (31.75)	1.57 (40)	4.41 (112)
52F226-020-200	8.23 (209)	0.75 (19)		1.50 (38.10)	1.57 (40)	4.41 (112)
High Performance						
52F226-029-10	5.12 (130)	0.47 (12)	0.67 (17)	0.75 (19.05)	0.63 (16)	3.50 (89)
52F226-029-16	5.47 (139)				0.71 (18)	3.70 (94)
52F226-029-32					1.02 (26)	4.13 (105)
52F226-029-63	6.81 (173)	0.63 (16)	1.06 (27)	1.25 (31.75)	1.26 (32)	5.71 (145)
52F226-029-100	8.98 (228)	0.75 (19)		1.50 (38.10)	1.57 (40)	7.17 (182)
52F226-029-200	11 (279)		1.57 (40)	2 (50.80)	1.57 (40)	7.17 (182)

Dimensions in inches (mm)

High Current AC Single Line Feed-through Series



RoHS
COMPLIANT

Features

- Voltage rating of 250VAC
- C configuration with Class Y2 capacitors
- Current rating up to 300 Amps
- Excellent filtering in compact package
- Bolt-in style with D-shaped bushing for easy installation
- Low cost EMI solution
- Design flexibility
- UL and Semko approvals pending

Applications

- Telecommunications (cellular base stations, telephone switching racks, etc.)
- Power supplies
- Medical equipment
- C.O.T.S. (Commercial-Off-The-Shelf) Military
- Industrial equipment controls
- Data transmission equipment

Specifications

Part Number	Rated Current	Min. Cap.	Minimum Insertion Loss (db) *										
			.01MHz	.10MHz	1MHz	10MHz	100MHz	1000MHz					
52F226-016-10	10A	2.2nF		-	-	9	30	45					
52F226-016-16	16A	4.7nF			2	15	34	54					
52F226-016-32	32A				4	21	41	60					
52F226-016-63	63A	10nF		2	15	34	53	74					
52F226-016-100	100A	47nF			5	21	40	60	85				
52F226-016-200	200A	100nF			5	21	40	60	85				
52F226-016-250	250A												
52F226-016-300	300A												
52F226-026-10	10A	4.7nF		-	-	2	15	34	54				
52F226-026-16	16A	10nF				4	21	41	60				
52F226-026-32	32A		2			15	34	53	74				
52F226-026-63	63A	47nF	5		21	40	60	85					
52F226-026-100	100A	100nF											
52F226-026-200	200A	220nF							10	27	47	67	90
52F226-026-250	250A												
52F226-026-300	300A												
52F226-036-16	16A	47nF	-		2	15	34	53	74				
52F226-036-32	32A	33nF				3	16		35	90			
52F226-036-63	63A	100nF		5		21	40	60	85				
52F226-036-100	100A	220nF		10	27	47	67	90					
52F226-036-200	200A	470nF							2	16	33	52	75
52F226-036-250	250A												
52F226-036-300	300A												
52F226-046-16	16A	100nF		-	5	21	40	60	85				
52F226-046-32	32A	47nF				2	15	34	53	74			
52F226-046-63	63A	220nF											
52F226-046-100	100A	470nF											
52F226-046-200	200A	1000nF	6		20						40	60	85
52F226-046-250	250A												
52F226-046-300	300A												

* Optimum performance with proper installation

High Current AC Single Line Feed-through Series

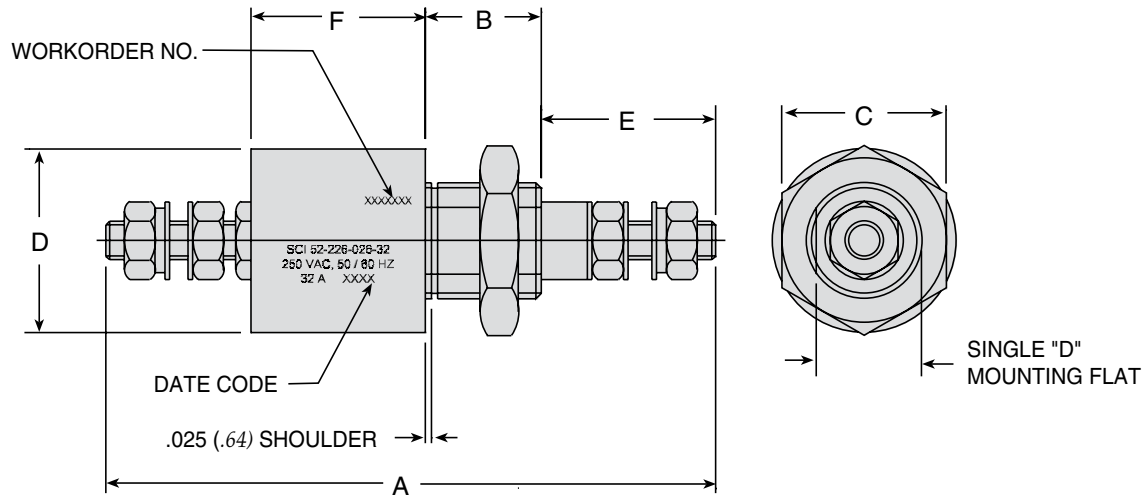

Dimensions

Part Number	A	B	C	D	E	F
52F226-016-10	2.24 (57)	0.39 (10)	0.51 (13)	0.56 (14.29)	0.63 (16)	0.71 (18)
52F226-016-16	2.48 (63)	0.47 (12)	0.67 (17)	0.75 (19.05)	0.71 (18)	
52F226-016-32						
52F226-016-63	3.78 (96)	0.55 (14)	0.87 (22)	1 (25.40)	1.02 (26)	1.18 (30)
52F226-016-100	4.45 (113)	0.63 (16)	1.06 (27)	1.25 (31.75)	1.26 (32)	1.30 (33)
52F226-016-200	5.12 (130)	0.75 (19)		1.5 (38.10)	1.57 (40)	
52F226-016-250	5.83 (148)		0.75 (19)	1.57 (40)	2 (50.80)	1.81 (46)
52F226-016-300						
52F226-026-10	2.24 (57)	0.39 (10)	0.51 (13)	0.56 (14.29)	0.63 (16)	0.71 (18)
52F226-026-16	2.48 (63)	0.47 (12)	0.67 (17)	0.75 (19.05)	0.71 (18)	
52F226-026-32						
52F226-026-63	3.78 (96)	0.55 (14)	0.87 (22)	1 (25.40)	1.02 (26)	1.18 (30)
52F226-026-100	4.45 (113)	0.63 (16)	1.06 (27)	1.25 (31.75)	1.26 (32)	1.30 (33)
52F226-026-200	5.12 (130)	0.75 (19)		1.5 (38.10)	1.57 (40)	
52F226-026-250	5.83 (148)		0.75 (19)	1.57 (40)	2 (50.80)	1.81 (46)
52F226-026-300						
52F226-036-16	2.95 (75)	0.47 (12)	0.67 (17)	0.75 (19.05)	0.71 (18)	1.18 (30)
52F226-036-32						
52F226-036-63	3.78 (96)	0.55 (14)	0.87 (22)	1 (25.40)	1.02 (26)	
52F226-036-100	4.57 (116)	0.75 (19)	1.06 (27)	1.5 (38.10)	1.26 (32)	1.30 (33)
52F226-036-200	5.79 (147)				1.57 (40)	
52F226-036-250	6.30 (160)		0.75 (19)	1.57 (40)	2 (50.80)	1.81 (46)
52F226-036-300						
52F226-046-16	3.03 (77)	0.55 (14)	0.87 (22)	1 (25.40)	0.71 (18)	1.18 (30)
52F226-046-32	2.95 (75)	0.47 (12)	0.67 (17)			
52F226-046-63	4.45 (113)	0.63 (16)	1.06 (27)	1.25 (31.75)	1.02 (26)	1.30 (33)
52F226-046-100	5.24 (133)	0.75 (19)		1.57 (40)	1.5 (38.10)	1.26 (32)
52F226-046-200	5.79 (147)		1.57 (40)		1.57 (40)	
52F226-046-250	6.30 (160)		0.75 (19)		1.57 (40)	2 (50.80)
52F226-046-300						

Dimensions in inches (mm)

High Current AC Single Line Pi Series



RoHS
COMPLIANT

Features

- Voltage rating of 250VAC
- Pi configuration with Class Y2 capacitors
- Current rating up to 300 Amps
- Excellent filtering in compact package
- Bolt-in style with D-shaped bushing for easy installation
- Low cost EMI solution
- Design flexibility
- UL and Semko approvals pending

Applications

- Telecommunications (cellular base stations, telephone switching racks, etc.)
- Power supplies
- Medical equipment
- C.O.T.S. (Commercial-Off-The-Shelf) Military
- Industrial equipment controls
- Data transmission equipment

Circuit Diagram

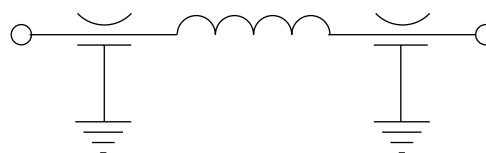

Specifications

Part Number	Rated Current	Min. Cap. (2X)	Minimum Insertion Loss (db) *					
			.01MHz	.10MHz	1MHz	10MHz	100MHz	1000MHz
Standard Performance								
52F226-037-10	10A	4.7nF	-	-	4	19	77	90
52F226-037-16	16A	10nF		1	8	22	50	
52F226-037-32	32A			4	21	52	80	
52F226-037-63	63A	47nF	1	8	25	73	90	
52F226-037-100	100A	100nF		9	26	75		
52F226-037-200	200A			1	21	57		
52F226-037-250	250A							
52F226-037-300	300A							
High Performance								
52F226-019-10	10A	10nF	-	1	9	30	80	90
52F226-019-16	16A	22nF		3	15	47		
52F226-019-32	32A			12	27	75		
52F226-019-63	63A	150nF	4	21	57	85	90	
52F226-019-100	100A	470nF						
52F226-019-200	200A							
52F226-019-250	250A							
52F226-019-300	300A							

* Optimum performance with proper installation

High Current AC Single Line Pi Series

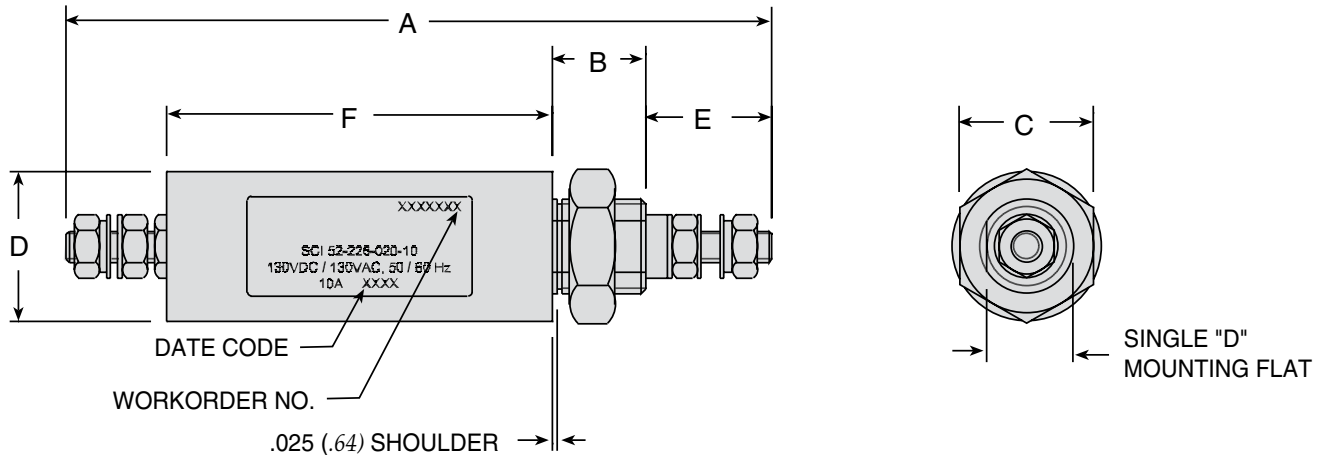

Dimensions

Part Number	A	B	C	D	E	F	
Standard Performance							
52F226-037-10	3.86 (98)	0.47 (12)	0.67 (17)	0.75 (19.05)	0.63 (16)	2.24 (57)	
52F226-037-16	4.17 (106)				0.71 (18)	2.40 (61)	
52F226-037-32					1.02 (26)	3.7 (94)	
52F226-037-63	6.30 (160)	0.55 (14)	0.87 (22)	1 (25.40)	1.26 (32)	4.09 (104)	
52F226-037-100	7.24 (184)	0.63 (16)	1.06 (27)	1.25 (31.75)	1.57 (40)	4.41 (112)	
52F226-037-200	8.23 (209)	0.75 (19)			1.57 (40)	1.81 (46)	3.66 (93)
52F226-037-250	7.87 (200)		1.5 (38.10)	1.57 (40)		1.81 (46)	3.66 (93)
52F226-037-300							
High Performance							
52F226-019-10	4.21 (107)	0.47 (12)	0.67 (17)	0.75 (19.05)	0.63 (16)	2.6 (66)	
52F226-019-16	4.57 (116)	0.55 (14)	0.87 (22)	1 (25.40)	0.71 (18)	2.72 (69)	
52F226-019-32							
52F226-019-63	6.81 (173)	0.63 (16)	1.06 (27)	1.25 (31.75)	1.02 (26)	4.13 (105)	
52F226-019-100	8.98 (228)	0.75 (19)		1.57 (40)	1.5 (38.10)	1.26 (32)	5.71 (145)
52F226-019-200	9.57 (243)		1.57 (40)		2 (50.80)	1.57 (40)	6.30 (160)
52F226-019-250	10.5 (267)						
52F226-019-300							

Dimensions in inches (mm)

High Current Filtered Terminal Blocks

Features

- Ideal for high current applications
- Design flexibility
- Available in 2 x 2 through 2 x 6 positions
- UL approved

Applications

- Telecommunications switching networks
- Cellular base stations
- Power supplies
- UPS
- Instrumentation
- High reliability radar and transmission systems
- Industrial controls
- Power distribution

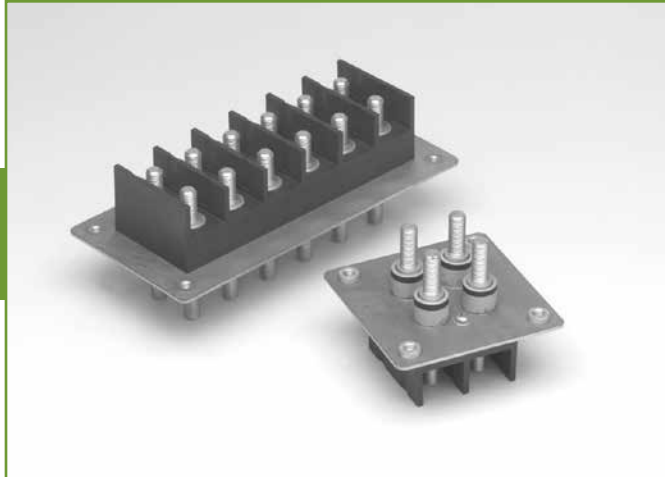

Specifications

ELECTRICAL

Voltage rating: 100 VDC per terminal
Capacitance: .015µF* +80% / -20% per cap
 .030µF +80% / -20% per pair
Dielectric withstanding voltage: 1000VDC for 1 minute
Current rating: 60 Amps max per terminal

Typical Insertion Loss — dB: In 50 Ohm Circuit		
1 MHz.....	8	70 MHz..... 36
5 MHz.....	24	100 MHz..... 33
10 MHz.....	32	160 MHz..... 25
50 MHz.....	38	200 MHz..... 25

MECHANICAL

Center spacing: US .200: (5.08 mm)
Wire size: AWG #12-26
Screw material: Steel, zinc chromate plate
Recommended PCB hole diameter: .05" (1.30 mm) contact hole
Molded material: UL rated 94VO polyamide
Tightening torque: 2.5 in.-lbs. max. (28 Ncm)
Terminal: Brass, tin-plated

* For filter elements with additional capacitance values, consult factory.

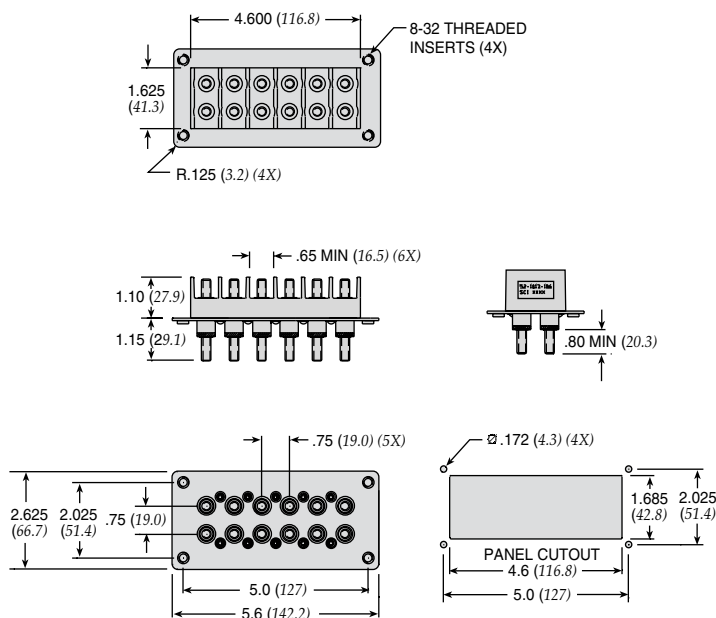

Part Number	Number of Terminals	A		B		C	
		in.	(mm)	in.	(mm)	in.	(mm)
52-1013-102	2x2	2.60	66.04	2.00	50.80	1.66	42.16
52-1013-103	2x3	3.35	85.09	2.75	69.85	2.41	61.21
52-1013-104	2x4	4.10	104.14	3.50	88.90	3.16	80.25
52-1013-105	2x5	4.85	123.19	4.25	107.95	3.91	99.31
52-1013-106	2x6	5.60	142.24	5.00	127.00	4.66	118.36

Dimensions in inches (mm)

Power Entry Modules Bolt-in Rear Terminals

60-BPR & BPS Series

Features

- Ideally suited for products that must conform to FCC part 15 regulations
- Metal case offers high performance
- Meets over voltage of IEC 664 category II and complies with IEC 950
- Uses IEC connector that meets most safety standards
- Solder lug and Fast-on tab terminals available
- Operating temperature: -25°C to +85°C (including temperature rise, see graph on page PF17)
- UL approved low leakage version also available

Applications

- Digital equipment
- Personal computers and peripherals
- Measuring instruments
- Monitor and display units



Tested and found to be IAW VDE 0565 Part 3.



Circuit Diagram

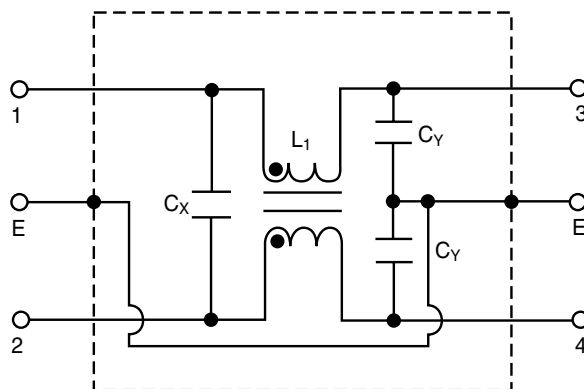

Specifications

Model*	Rated Voltage (@ 50/60Hz)	Rated Current	Leakage Current (Max.)	Capacitance		Inductance (L ₁)	Temperature Rise (Max.)
				C _Y	C _X		
60-XXX-010-3-2	250VAC	1A	0.35mA	2200pF ± 20%	.022uF ± 20%	6.0mH	30°C
60-XXX-010-3-4					.047uF ± 20%		
60-XXX-010-5-2			0.50mA	3300pF ± 20%	.022uF ± 20%		
60-XXX-010-5-4					.047uF ± 20%		
60-XXX-020-3-2	250VAC	2A	0.35mA	2200pF ± 20%	.022uF ± 20%	2.4mH	30°C
60-XXX-020-3-4					.047uF ± 20%		
60-XXX-020-5-2			0.50mA	3300pF ± 20%	.022uF ± 20%		
60-XXX-020-5-4					.047uF ± 20%		
60-XXX-030-3-2	250VAC	3A	0.35mA	2200pF ± 20%	.022uF ± 20%	1.2mH	30°C
60-XXX-030-3-4					.047uF ± 20%		
60-XXX-030-5-2			0.50mA	3300pF ± 20%	.022uF ± 20%		
60-XXX-030-5-4					.047uF ± 20%		
60-XXX-060-3-2	250VAC	6A	0.35mA	2200pF ± 20%	.022uF ± 20%	0.53mH	45°C
60-XXX-060-3-4					.047uF ± 20%		
60-XXX-060-5-2			0.50mA	3300pF ± 20%	.022uF ± 20%		
60-XXX-060-5-4					.047uF ± 20%		
60-XXX-100-3-2	250VAC	10A	0.35mA	2200pF ± 20%	.022uF ± 20%	0.26mH	45°C
60-XXX-100-5-2			0.50mA	3300pF ± 20%	.022uF ± 20%		
60-BPR-150-3-11	250VAC	15A	0.35mA	2200pF ± 20%	.1uF ± 20%	0.15mH	45°C

Note: Test voltage: 1500VAC one minute, line to ground
Insulation resistance: 300 Mohm min. at 500VDC
Voltage drop: 1V max. at rated current
Weight: 45g
Input: Compatible with IEC-320

* Substitute BPR or BPS for XXX

BPS - Solder lug terminals
BPR - Fast-on tab terminals

Power Entry Modules Bolt-in Rear Terminals

60-BPR & BPS Series

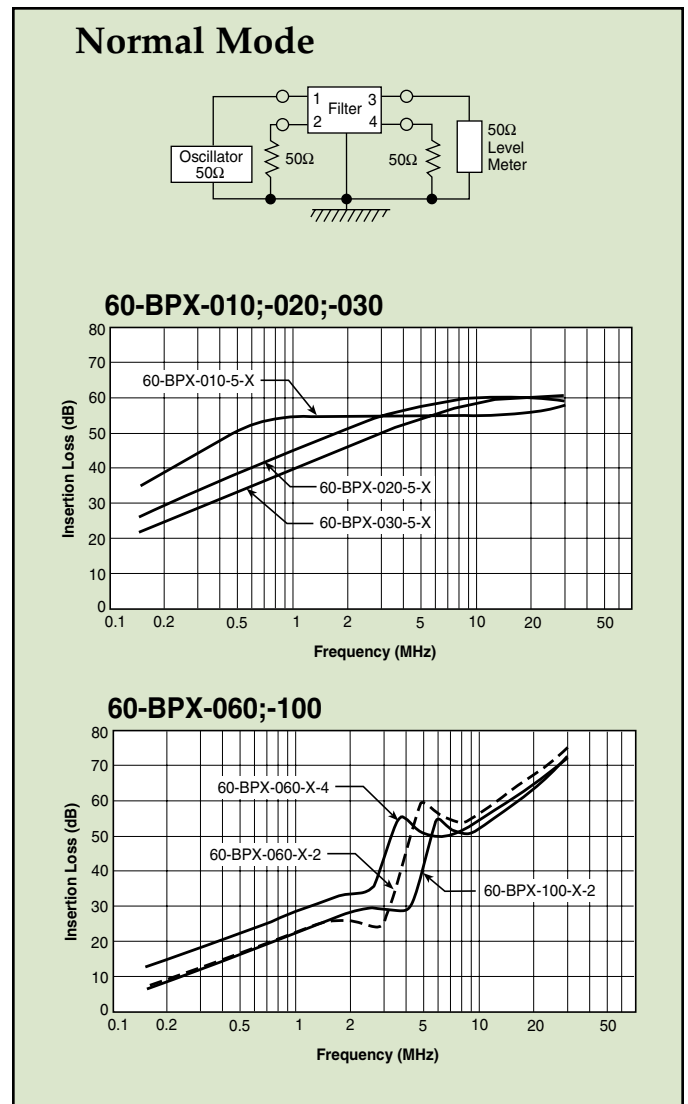
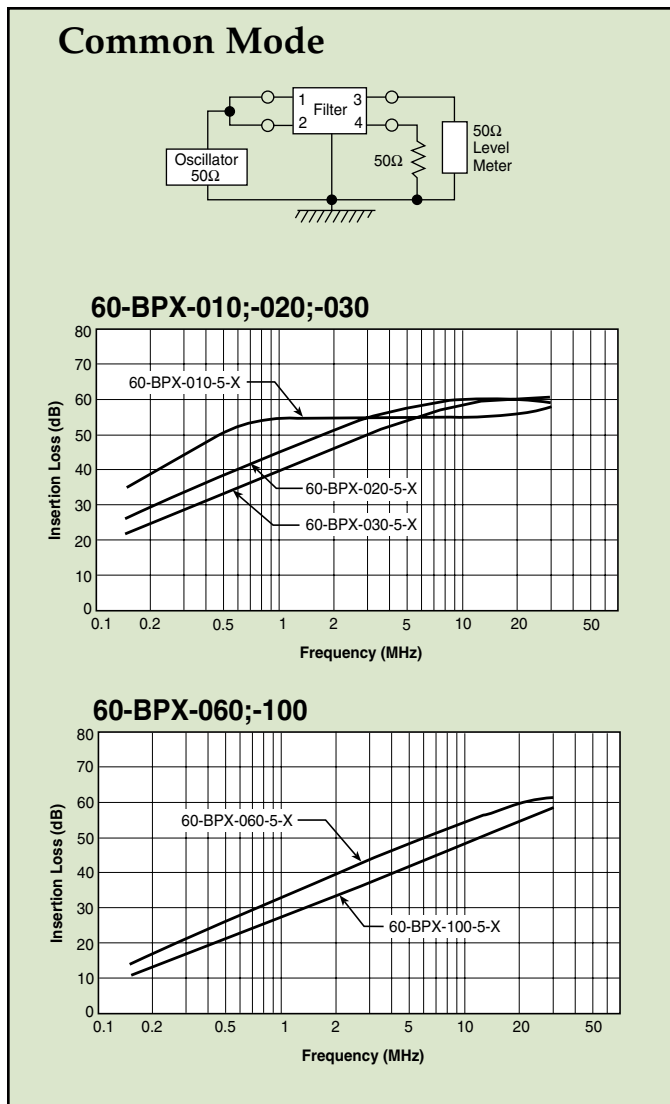
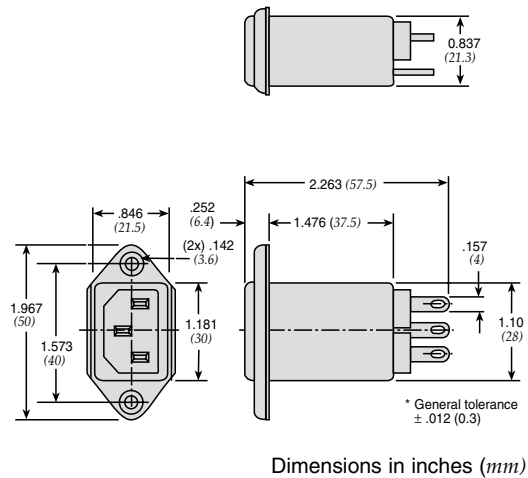
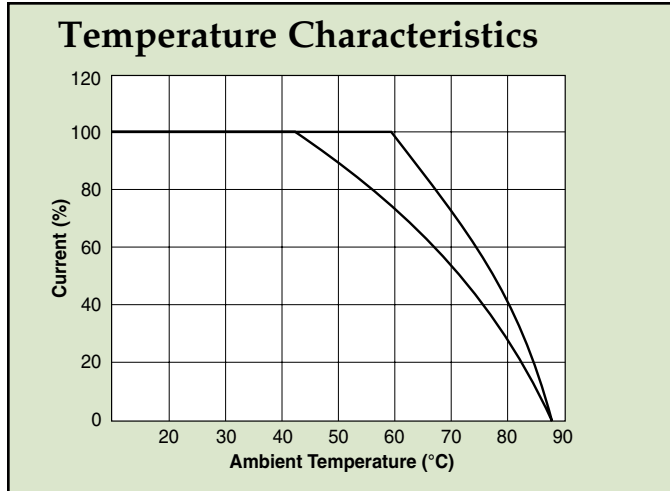

Power Entry Modules Bolt-in Right Angle Terminals



60-BPF Series

Features

- Ideally suited for products that must conform to FCC part 15 regulations
- Metal case offers high performance
- Meets over voltage of IEC 664 category II and complies with IEC 950
- Uses IEC connector that meets most safety standards
- PCB mounting types available (see page PF46)
- Length under tab is shortened for small spaces
- Operating temperature: -25°C to +85°C (including temperature rise, see graph on page PF19)
- UL approved low leakage version also available



Tested and found to be IAW VDE 0565 Part 3.

Applications

- Digital equipment
- Personal computers and peripherals
- Measuring instruments
- Monitor and display units

Circuit Diagram

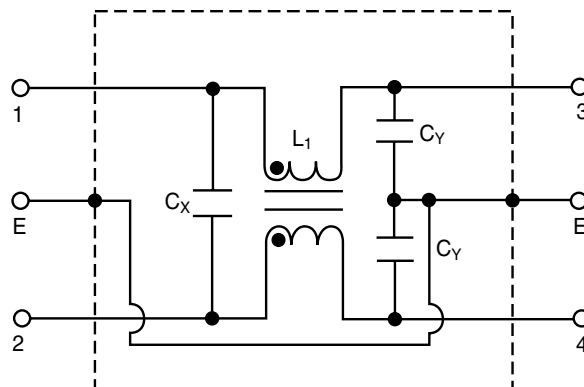

Specifications

Model	Rated Voltage (@ 50/60Hz)	Rated Current	Leakage Current (Max.)	Capacitance		Inductance (L ₁)	Temperature Rise (Max.)
				C _Y	C _X		
60-BPF-010-3-2	250VAC	1A	0.35mA	2200pF ± 20%	.022uF ± 20%	6.0mH	30°C
60-BPF-010-3-4					.047uF ± 20%		
60-BPF-010-5-2			0.50mA	3300pF ± 20%	.022uF ± 20%		
60-BPF-010-5-4					.047uF ± 20%		
60-BPF-020-3-2	250VAC	2A	0.35mA	2200pF ± 20%	.022uF ± 20%	2.4mH	30°C
60-BPF-020-3-4					.047uF ± 20%		
60-BPF-020-5-2			0.50mA	3300pF ± 20%	.022uF ± 20%		
60-BPF-020-5-4					.047uF ± 20%		
60-BPF-030-3-2	250VAC	3A	0.35mA	2200pF ± 20%	.022uF ± 20%	1.2mH	30°C
60-BPF-030-3-4					.047uF ± 20%		
60-BPF-030-5-2			0.50mA	3300pF ± 20%	.022uF ± 20%		
60-BPF-030-5-4					.047uF ± 20%		
60-BPF-060-3-2	250VAC	6A	0.35mA	2200pF ± 20%	.022uF ± 20%	0.53mH	45°C
60-BPF-060-3-4					.047uF ± 20%		
60-BPF-060-5-2			0.50mA	3300pF ± 20%	.022uF ± 20%		
60-BPF-060-5-4					.047uF ± 20%		

Note: Test voltage: 1500VAC one minute, line to ground
 Insulation resistance: 300 Mohm min. at 500VDC
 Voltage drop: 1V max. at rated current
 Weight: 50g
 Input: Compatible with IEC-320

Power Entry Modules Bolt-in Right Angle Terminals

60-BPF Series

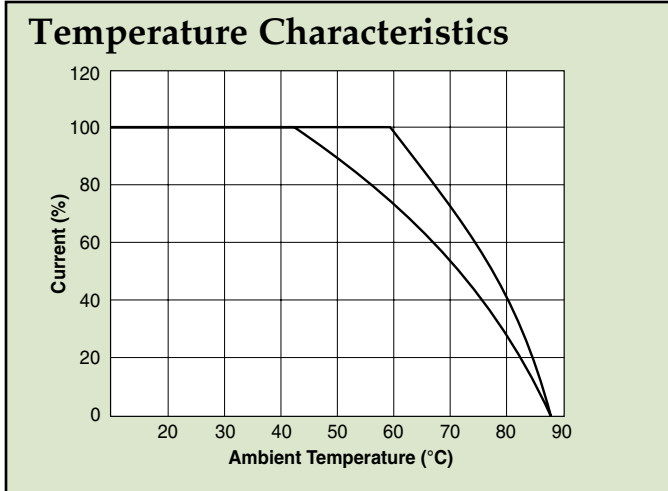

60-BPF Fast-on Terminals

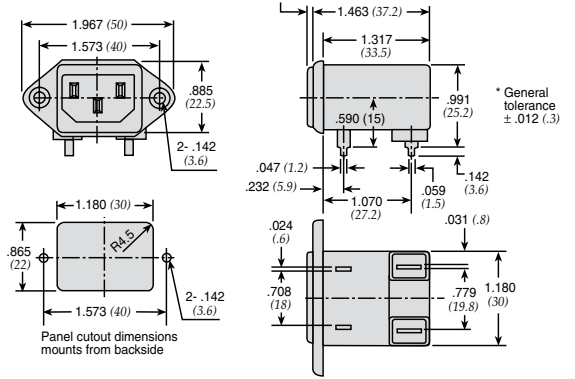

Dimensions in inches (mm)

Common Mode

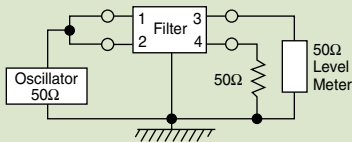

60-BPF-010;-020

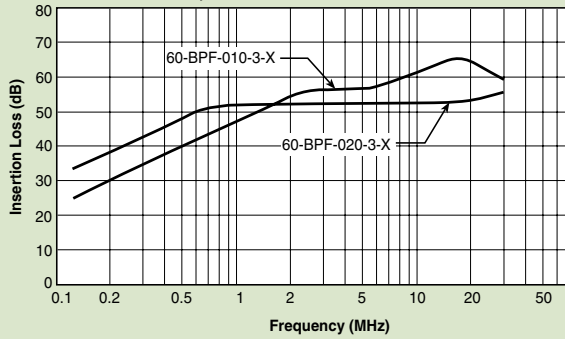

60-BPF-030;-060

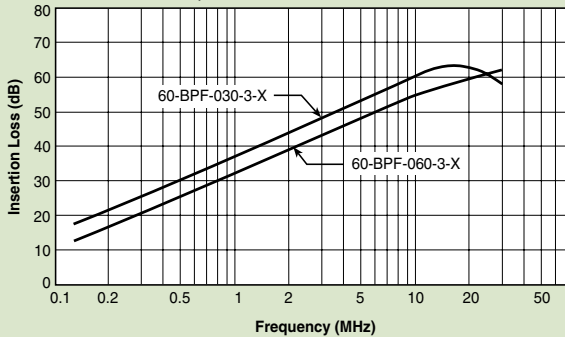

Normal Mode

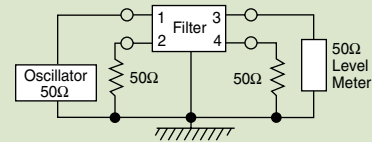

60-BPF-010;-020

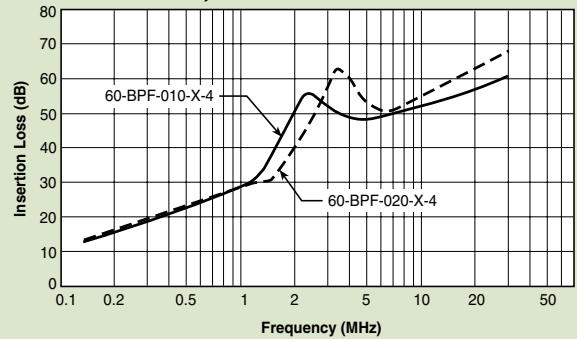

60-BPF-030;-060

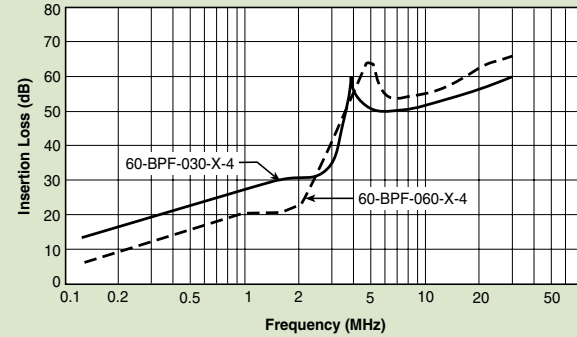

Power Entry Modules High Frequency Attenuation



60-BHS Series

Features

- Ideally suited for products that must conform to FCC part 15 regulations
- Metal cased miniature filter offers high performance
- Meets over voltage of IEC 664 category II and complies with IEC 950
- PCB mounting types available (see page PF48)
- PCB mounting minimizes space and provides economical installation
- Excellent filtering characteristics for high frequencies
- Earth coil standard
- Operating temperature: -25°C to +85°C (including temperature rise, see graph on page PF21)



Tested and found to be IAW VDE 0565 Part 3.

Applications

- Digital equipment
- Personal computers and peripherals
- Measuring instruments
- Monitor and display units

Circuit Diagram

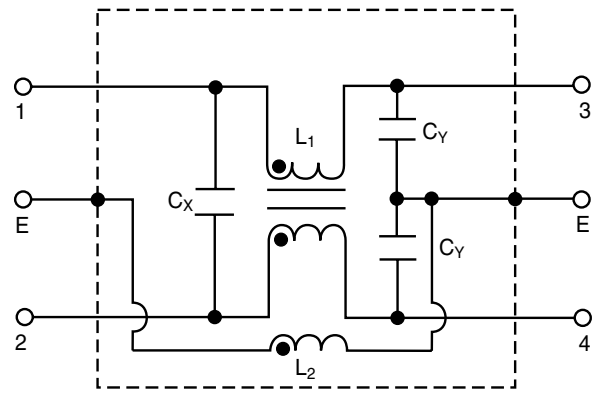

Specifications

Model	Rated Voltage (@ 50/60Hz)	Rated Current	Leakage Current (Max.)	Capacitance		Inductance (L ₁) (L ₂)		Temperature Rise (Max.)
				C _Y	C _X	(L ₁)	(L ₂)	
60-BHS-010-3-11	250VAC	1A	0.35mA	2200pF ± 20%	0.1uF ± 20%	6mH	18.3uH	30°C
60-BHS-010-3-4					.047uF ± 20%			
60-BHS-010-5-11			0.50mA	3300pF ± 20%	0.1uF ± 20%			
60-BHS-010-5-4					.047uF ± 20%			
60-BHS-020-3-11	250VAC	2A	0.35mA	2200pF ± 20%	0.1uF ± 20%	2.4mH	18.3uH	30°C
60-BHS-020-3-4					.047uF ± 20%			
60-BHS-020-5-11			0.50mA	3300pF ± 20%	0.1uF ± 20%			
60-BHS-020-5-4					.047uF ± 20%			
60-BHS-030-3-11	250VAC	3A	0.35mA	2200pF ± 20%	0.1uF ± 20%	1.2mH	18.3uH	30°C
60-BHS-030-3-4					.047uF ± 20%			
60-BHS-030-5-11			0.50mA	3300pF ± 20%	0.1uF ± 20%			
60-BHS-030-5-4					.047uF ± 20%			
60-BHS-060-3-11	250VAC	6A	0.35mA	2200pF ± 20%	0.1uF ± 20%	.53mH	18.3uH	45°C
60-BHS-060-3-4					.047uF ± 20%			
60-BHS-060-5-11			0.50mA	3300pF ± 20%	0.1uF ± 20%			
60-BHS-060-5-4					.047uF ± 20%			

Note: Test voltage: 1500VAC one minute, line to ground
 Insulation resistance: 300 Mohm min. at 500VDC
 Voltage drop: 1V max. at rated current
 Weight: 50g
 Input: Compatible with IEC-320

Power Entry Modules High Frequency Attenuation

60-BHS Series

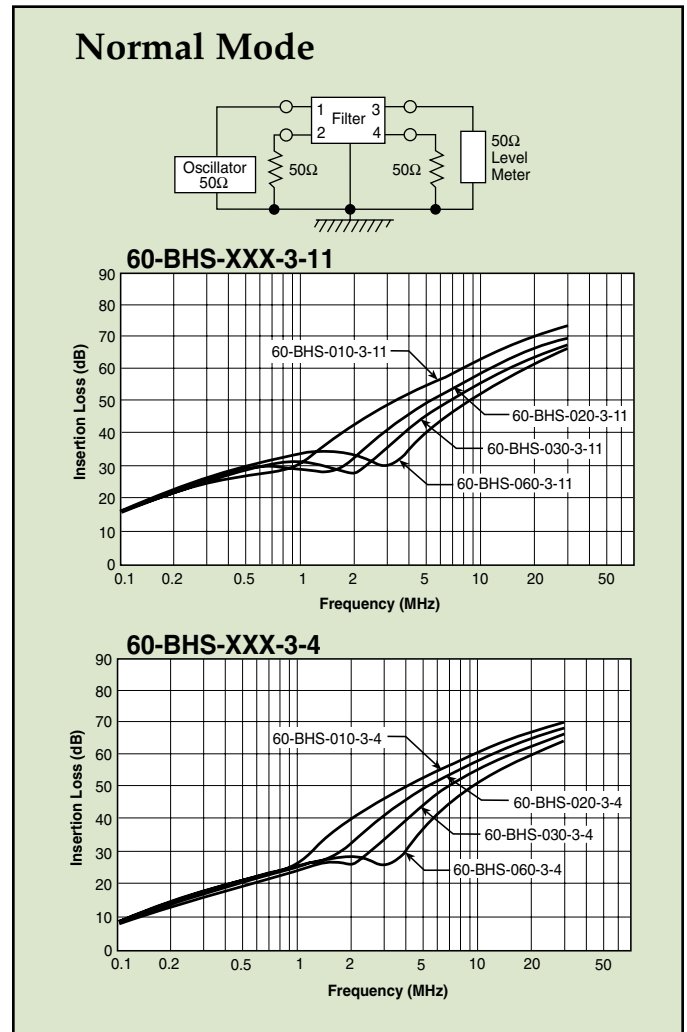
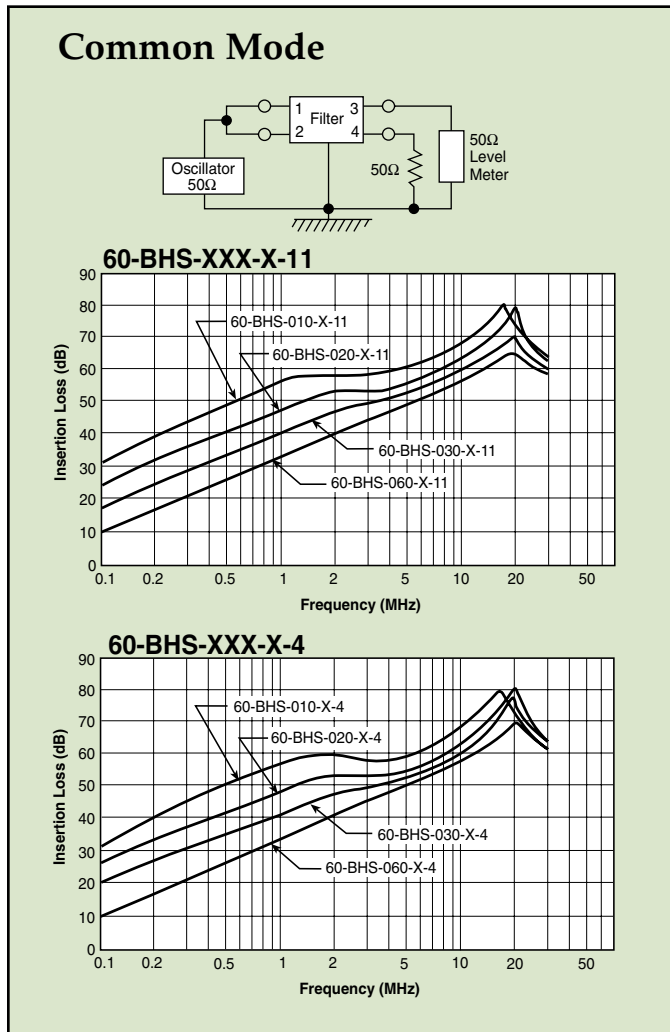
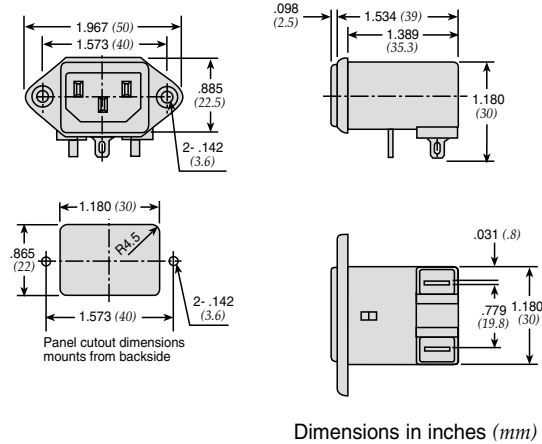
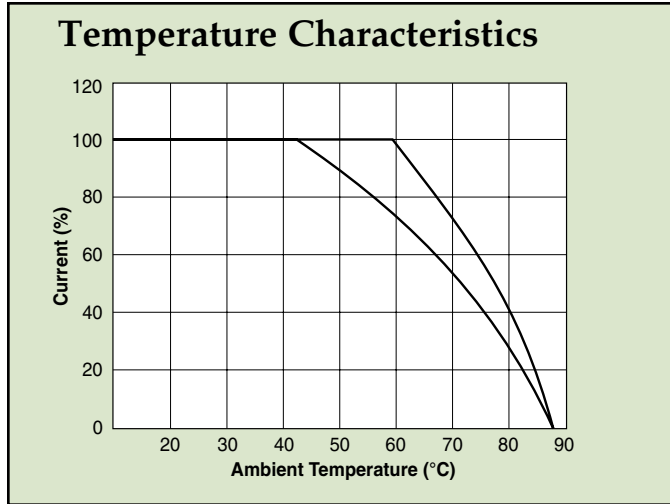

Power Entry Modules Bolt-in Rear Terminals

For General Purpose Applications

10-BPF Series



Features

- Ideally suited for products that must conform to FCC part 15 regulations
- Metal case offers high performance
- Meets over voltage of IEC 664 category II and complies with IEC 950
- Uses IEC connector that meets most safety standards
- Operating temperature: -25°C to +70°C
- Compact configuration

Applications

- Digital equipment
- Personal computers and peripherals
- Measuring instruments
- Monitor and display units



Circuit Diagram

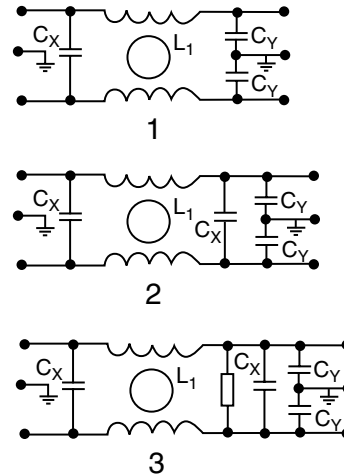

Specifications

Model	Rated Voltage (@ 50/60Hz)	Rated Current	Leakage Current (Max.)	Capacitance		Inductance (L ₁)	Circuit Diagram	Figure	Temperature Rise (Max.)
				C _y	C _x				
10-BPF-001-5-A	120/250VAC	1A	0.50mA	3300pF	2200pF	3.0mH	1	A	30°C
10-BPF-001-5-C								C	
10-BPF-003-5-A		3A		0.01uF	1.5mH	2	A		
10-BPF-003-5-C							C		
10-BPF-003-5-D		6A		0.01uF	0.5mH	1	B		
10-BPF-006-5-A							A		
10-BPF-006-5-C							C		
10-BPF-006-5-D							B		
10-BPF-010-5-A		10A		0.01uF	0.5mH	1	A		
10-BPF-010-5-D							B		

Note: Test voltage: 1500VAC one minute, line to ground
 Insulation resistance: 300 Mohm min. at 500VDC
 Voltage drop: 1V max. at rated current
 Weight: 45g
 Input: Compatible with IEC-320

Power Entry Modules Bolt-in Rear Terminals For General Purpose Applications

Figure A

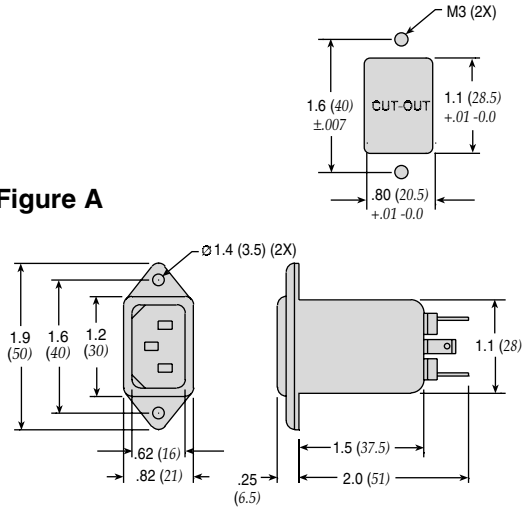

Figure B

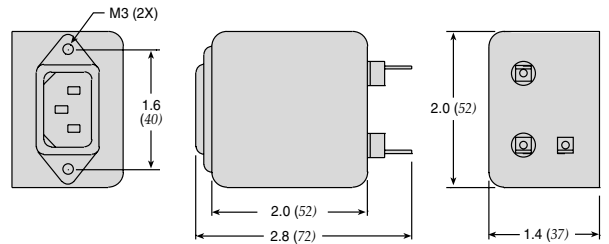
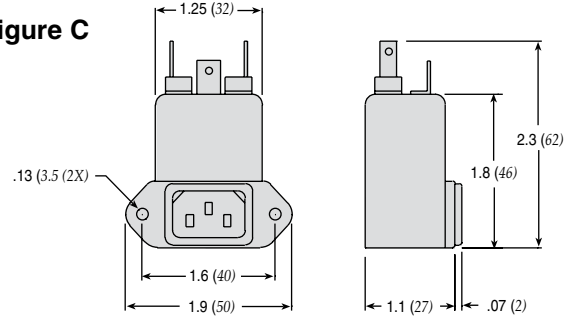
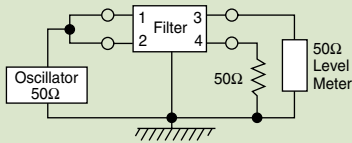

Figure C



Dimensions in inches (mm)

Common Mode



10-BPF-001;-003

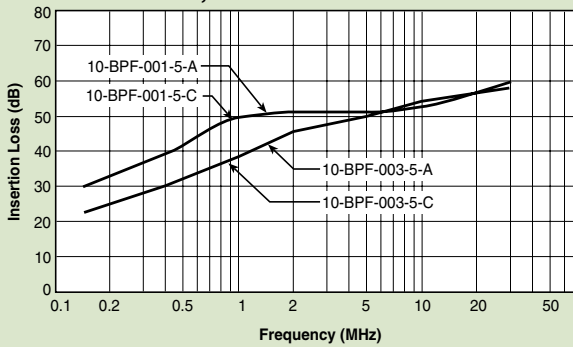

10-BPF-006;-010

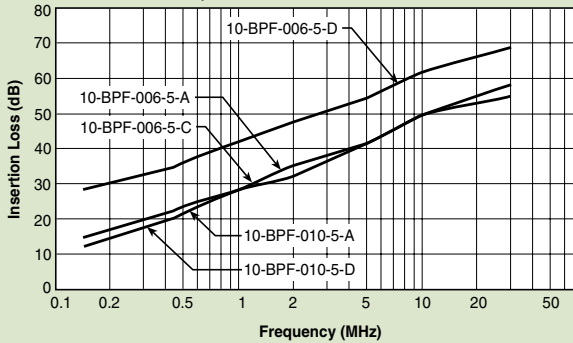

Normal Mode

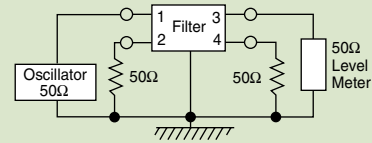

10-BPF-001;-003

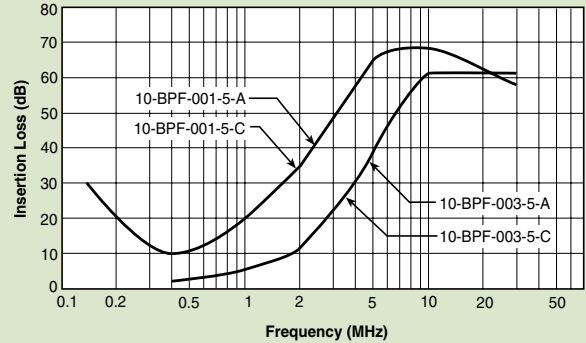

10-BPF-006;-010

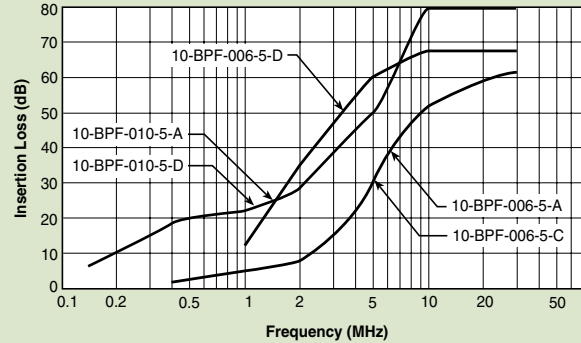

Power Entry Modules Bolt-in Rear Terminals

For Medical Purpose Applications



10-BPF Series



Features

- Ideally suited for products that must conform to FCC part 15 regulations
- Metal case offers high performance
- Meets over voltage of IEC 664 category II and complies with IEC 950
- Uses IEC connector that meets most safety standards
- Operating temperature: -25°C to +70°C
- Compact configuration
- Low leakage current

Applications

- Digital equipment
- Personal computers and peripherals
- Measuring instruments
- Monitor and display units

Circuit Diagram

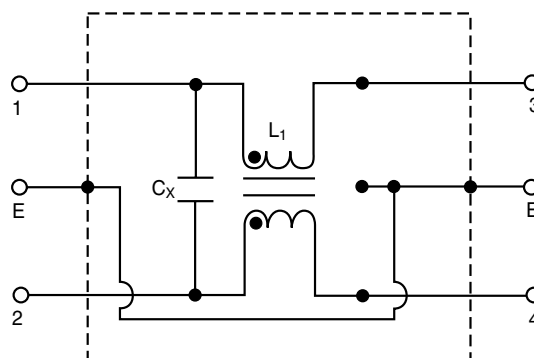

Specifications

Model	Rated Voltage (@ 50/60Hz)	Rated Current	Leakage Current (Max.)	Capacitance C _x	Inductance (L ₁)	Circuit Diagram	Figure	Temperature Rise (Max.)
10-BPF-001-2-A	120/250VAC	1A	5uA	0.01uF	3.0mH	1	A	30°C
10-BPF-003-2-A		3A			1.5mH			
10-BPF-006-2-A		6A			0.5mH			

Note: Test voltage: 1500VAC one minute, line to ground
 Insulation resistance: 300 Mohm min. at 500VDC
 Voltage drop: 1V max. at rated current
 Weight: 45g
 Input: Compatible with IEC-320

Power Entry Modules Bolt-in Rear Terminals For Medical Purpose Applications

10-BPF Series

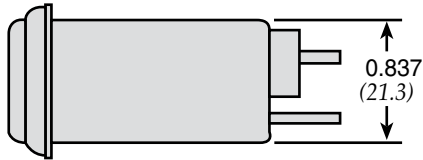

Dimensions in inches (mm)

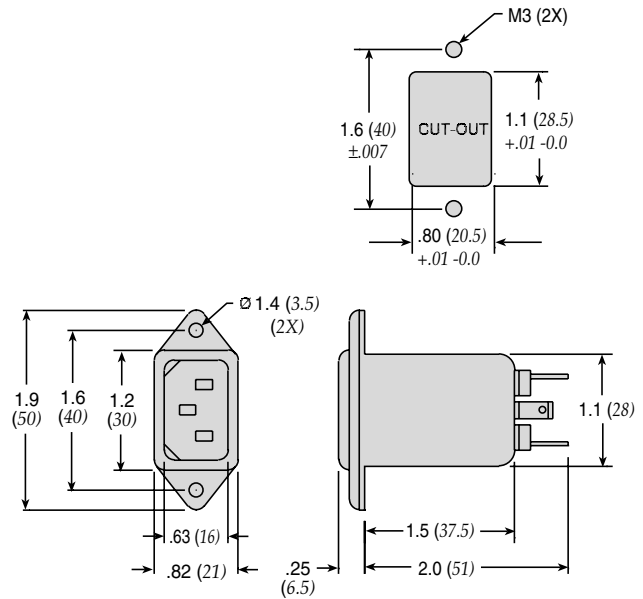

Common Mode

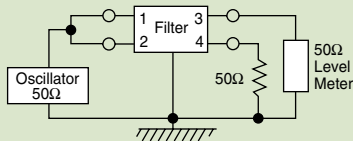

10-BPF-001;-003;-006

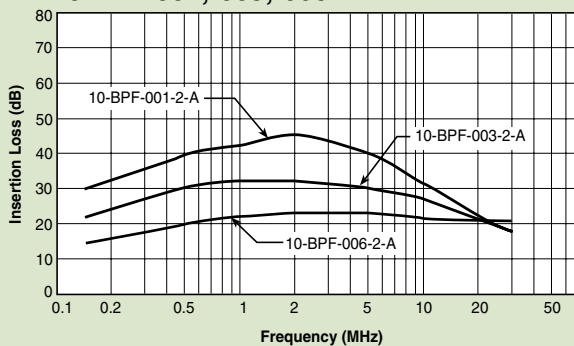

Normal Mode

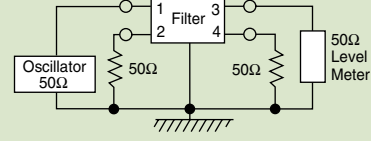

10-BPF-001;-003;-006

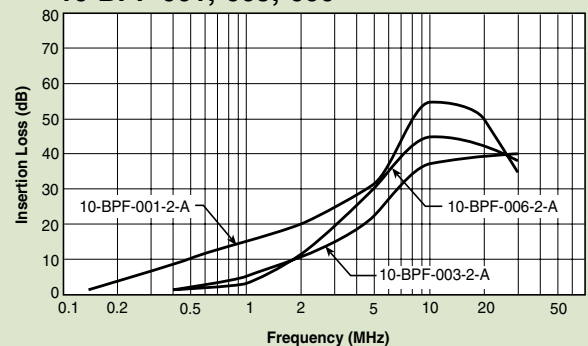

Power Entry Modules Snap-in with Wire Leads



60-SPL Series

Features

- Ideally suited for products that must conform to FCC part 15 regulations
- Metal cased miniature filter offers high performance
- Meets over voltage of IEC 664 category II and complies with IEC 950
- Uses IEC connector that meets most safety standards
- Snap-in style saves labor and hardware inventory
- Wire output minimizes space and provides economical installation
- Operating temperature: -25°C to +85°C (including temperature rise, see graph on page PF27)



Tested and found to be IAW VDE 0565 Part 3.

Applications

- Digital equipment
- Personal computers and peripherals
- Measuring instruments
- Monitor and display units

Circuit Diagram

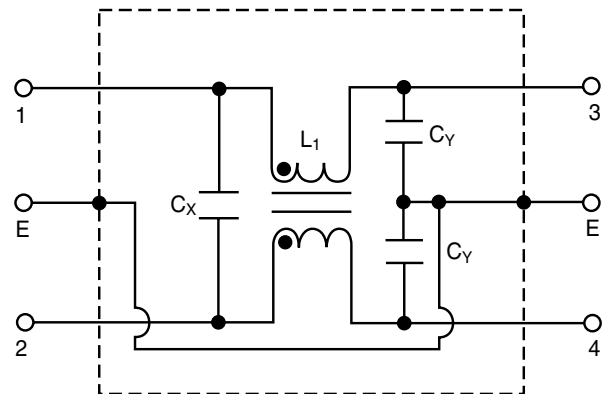

Specifications

Model	Rated Voltage (@ 50/60Hz)	Rated Current	Leakage Current (Max.)	Capacitance		Inductance (L ₁)	Temperature Rise (Max.)	
				C _Y	C _X			
60-SPL-010-3-2	250VAC	1A	0.35mA	2200pF ± 20%	22nF ± 20%	6.0mH	30°C	
60-SPL-010-3-3					33nF ± 20%			
60-SPL-010-5-2			0.50mA	3300pF ± 20%	22nF ± 20%			
60-SPL-010-5-3					33nF ± 20%			
60-SPL-020-3-2	250VAC	2A	0.35mA	2200pF ± 20%	22nF ± 20%	2.4mH	30°C	
60-SPL-020-3-3					33nF ± 20%			
60-SPL-020-5-2			0.50mA	3300pF ± 20%	22nF ± 20%			
60-SPL-020-5-3					33nF ± 20%			
60-SPL-030-3-2	250VAC	3A	0.35mA	2200pF ± 20%	.022uF ± 20%	1.2mH	30°C	
60-SPL-030-3-3				3300pF ± 20%				
60-SPL-030-5-2			0.50mA	3300pF ± 20%	2200pF ± 20%			.033uF ± 20%
60-SPL-030-5-3					3300pF ± 20%			
60-SPL-060-3-2	250VAC	6A	0.35mA	2200pF ± 20%	22nF ± 20%	0.53mH	45°C	
60-SPL-060-3-3					33nF ± 20%			
60-SPL-060-5-2			0.50mA	3300pF ± 20%	22nF ± 20%			
60-SPL-060-5-3					33nF ± 20%			

Note: Test voltage: 1500VAC one minute, line to ground
 Insulation resistance: 300 Mohm min. at 500VDC
 Voltage drop: 1V max. at rated current
 Weight: 50g
 Input: Compatible with IEC-320

Power Entry Modules Snap-in with Wire Leads

60-SPL Series

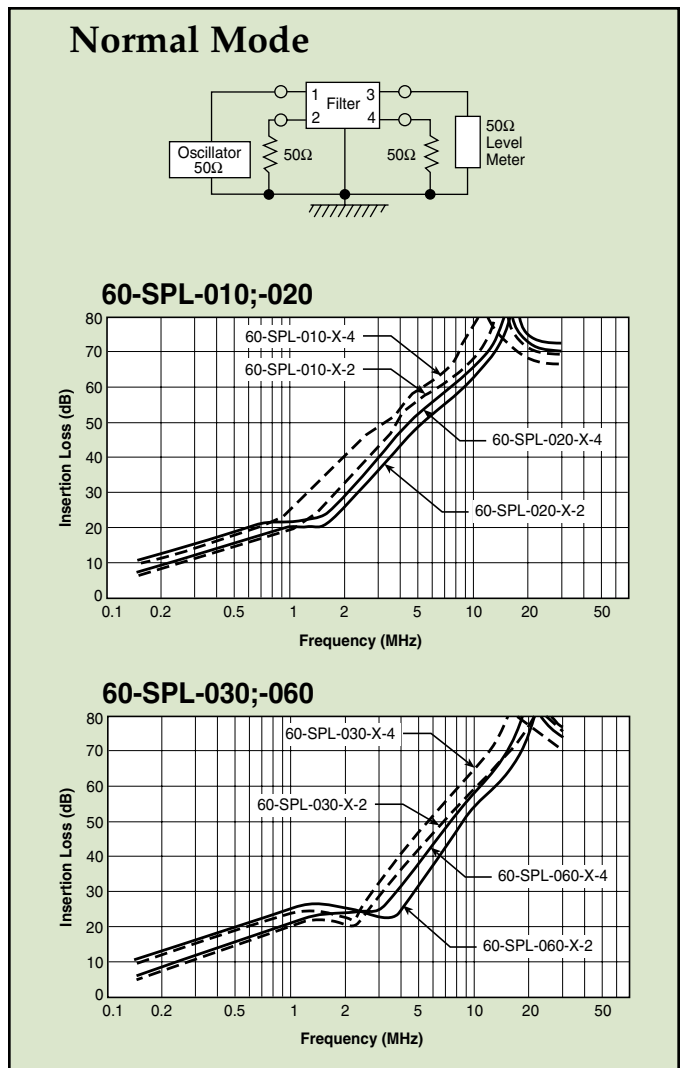
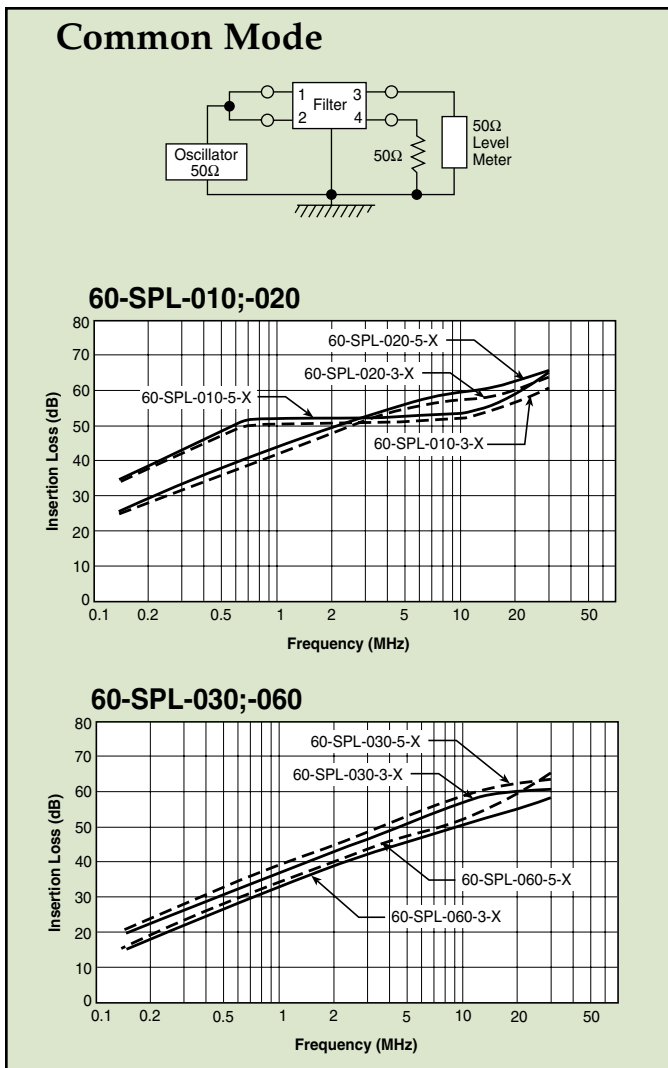
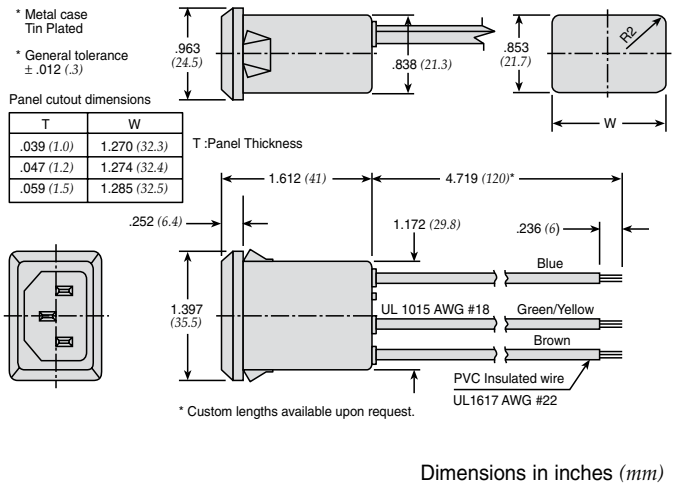
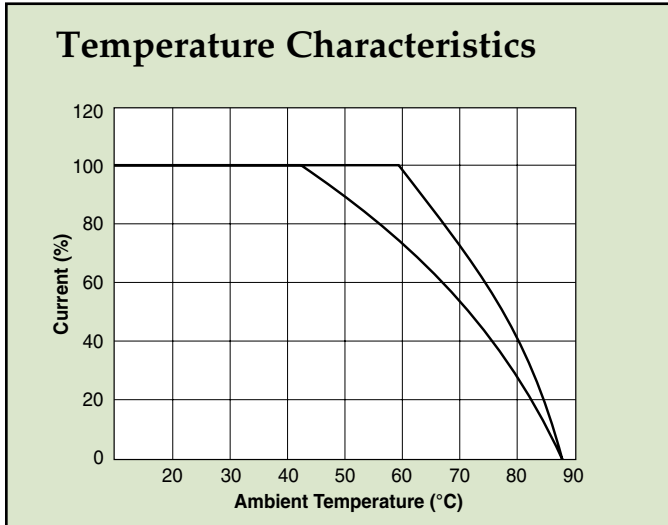

Power Entry Modules Bolt-in with Wire Leads



60-BPL Series

Features

- Ideally suited for products that must conform to FCC part 15 regulations
- Metal case filter offers high performance
- Meets over voltage of IEC 664 category II and complies with IEC 950
- Uses IEC connector that meets most safety standards
- Wire output for minimizing space use and economical installation
- Operating temperature: -25°C to +85°C (including temperature rise, see graph on page PF28)



Tested and found to be IAW VDE 0565 Part 3.

Applications

- Digital equipment
- Personal computers and peripherals
- Measuring instruments
- Monitor and display units

Circuit Diagram

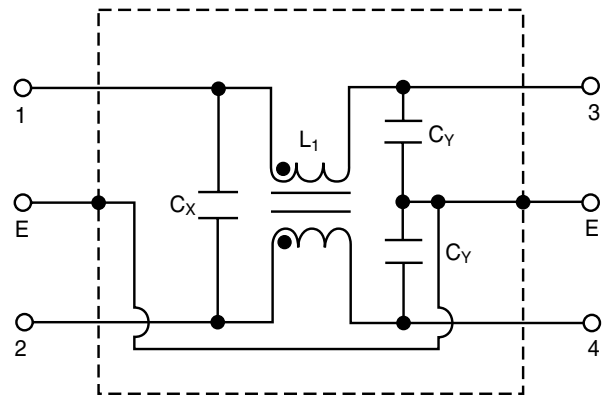

Specifications

Model	Rated Voltage (@ 50/60Hz)	Rated Current	Leakage Current (Max.)	Capacitance		Inductance (L ₁)	Temperature Rise (Max.)	
				C _Y	C _X			
60-BPL-010-3-2	250VAC	1A	0.35mA	2200pF ± 20%	22nF ± 20%	6.0mH	30°C	
60-BPL-010-3-3					33nF ± 20%			
60-BPL-010-5-2			0.50mA	3300pF ± 20%	22nF ± 20%			
60-BPL-010-5-3					33nF ± 20%			
60-BPL-020-3-2	250VAC	2A	0.35mA	2200pF ± 20%	22nF ± 20%	2.4mH	30°C	
60-BPL-020-3-3					33nF ± 20%			
60-BPL-020-5-2			0.50mA	3300pF ± 20%	22nF ± 20%			
60-BPL-020-5-3					33nF ± 20%			
60-BPL-030-3-2	250VAC	3A	0.35mA	2200pF ± 20%	.022uF ± 20%	1.2mH	30°C	
60-BPL-030-3-3				3300pF ± 20%				
60-BPL-030-5-2			0.50mA	3300pF ± 20%	2200pF ± 20%			.033uF ± 20%
60-BPL-030-5-3					3300pF ± 20%			
60-BPL-060-3-2	250VAC	6A	0.35mA	2200pF ± 20%	22nF ± 20%	0.53mH	45°C	
60-BPL-060-3-3					33nF ± 20%			
60-BPL-060-5-2			0.50mA	3300pF ± 20%	22nF ± 20%			
60-BPL-060-5-3					33nF ± 20%			

Note: Test voltage: 1500VAC one minute, line to ground
 Insulation resistance: 300 Mohm min. at 500VDC
 Voltage drop: 1V max. at rated current
 Weight: 50g
 Input: Compatible with IEC-320

Power Entry Modules Bolt-in with Wire Leads

60-BPL Series

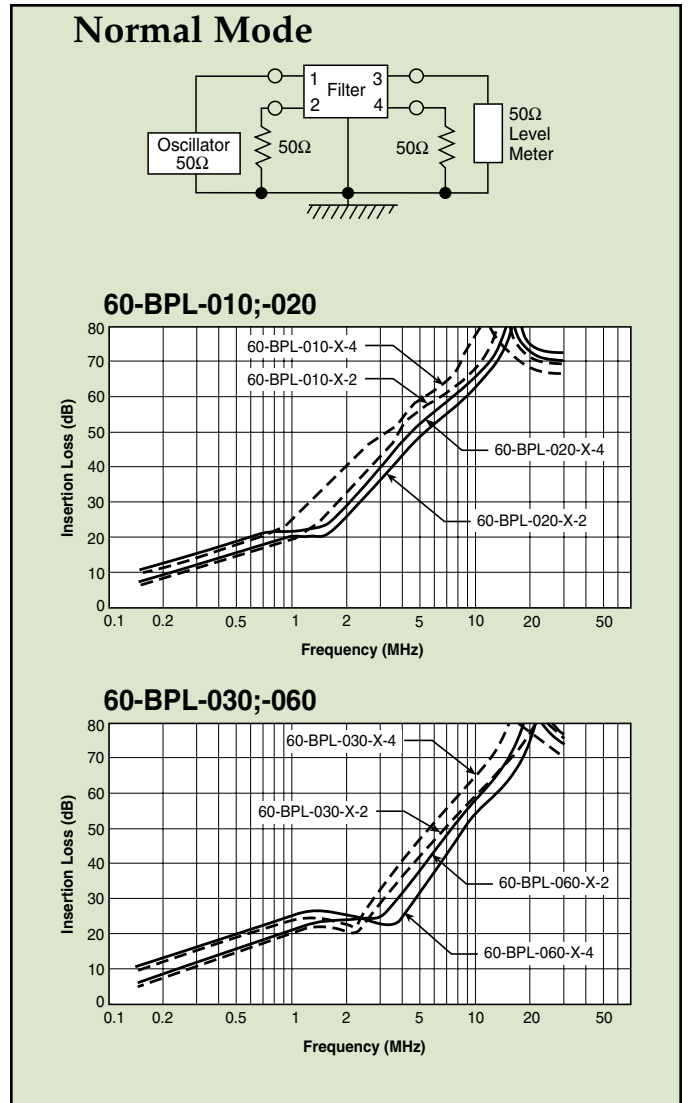
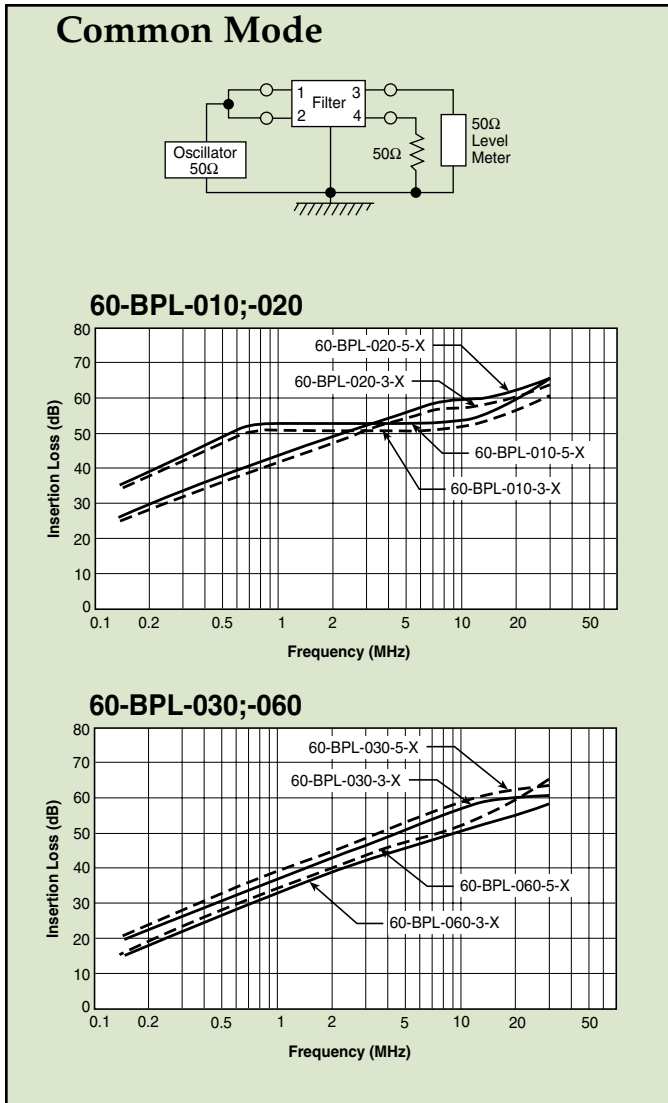
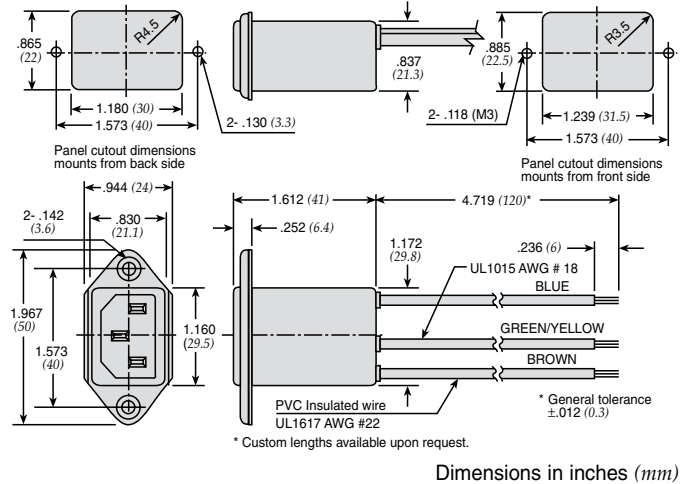
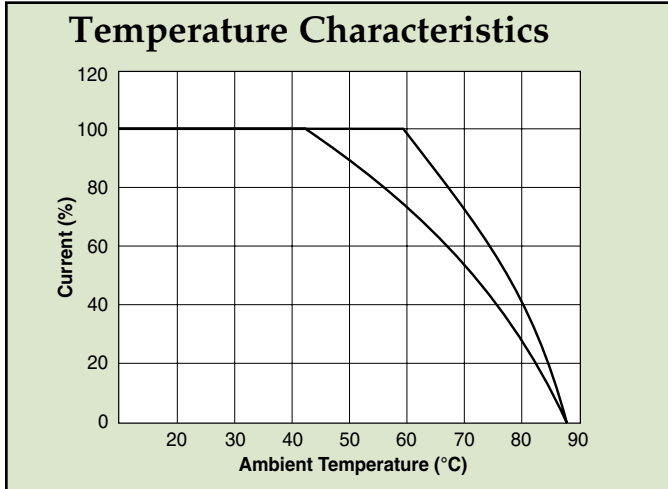

Power Entry Modules Bolt-in with Wire Leads



10-BPL Series



Features

- Ideally suited for products that must conform to FCC part 15 regulations
- Metal case filter offers high performance
- Meets over voltage of IEC 664 category II and complies with IEC 950
- Uses IEC connector that meets most safety standards
- Wire output for minimizing space use and economical installation
- Operating temperature: -25°C to +70°C
- Compact configuration

Applications

- Digital equipment
- Personal computers and peripherals
- Measuring instruments
- Monitor and display units

Circuit Diagram

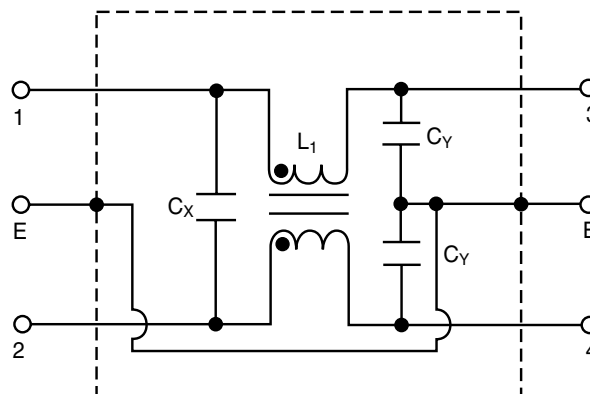

Specifications

Model	Rated Voltage (@ 50/60Hz)	Rated Current	Leakage Current (Max.)	Capacitance		Inductance (L ₁)	Circuit Diagram	Figure	Temperature Rise (Max.)
				C _y	C _x				
10-BPL-001-5-B	250VAC	1A	0.50mA	3300pF	0.01uF	3.0mH	1	A	30°C
10-BPL-003-5-B		3A				1.5mH			
10-BPL-006-5-B		6A				0.5mH			

Note: Test voltage: 1500VAC one minute, line to ground
 Insulation resistance: 300 Mohm min. at 500VDC
 Voltage drop: 1V max. at rated current
 Weight: 50g
 Input: Compatible with IEC-320

Power Entry Modules Bolt-in with Wire Leads

10-BPL Series

Figure A

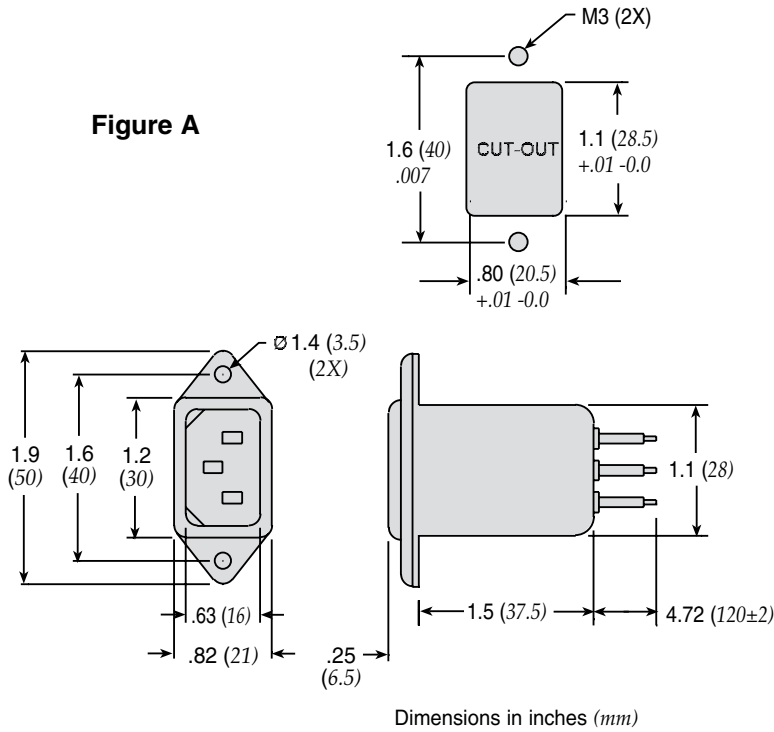

Common Mode

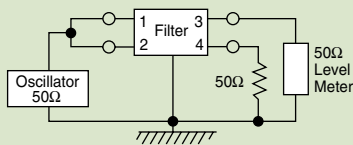

10-BPL-001;-003;-006

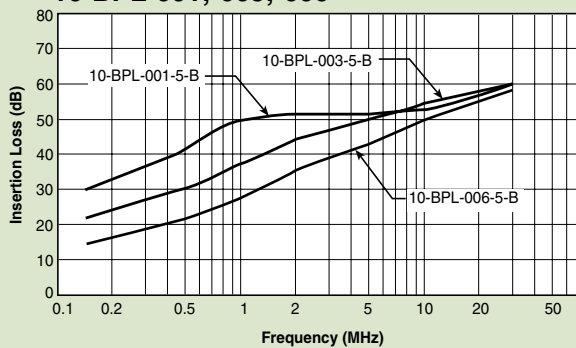

Normal Mode

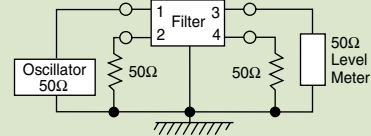

10-BPL-001;-003;-006

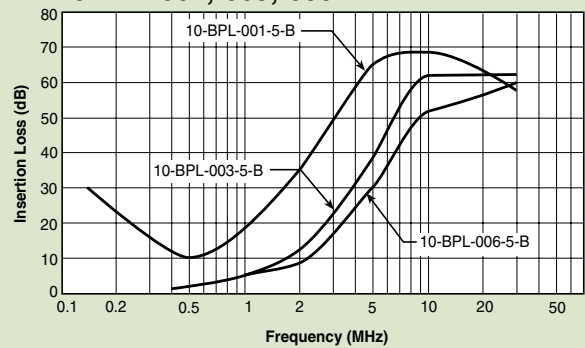

Power Entry Modules Snap-in Mount

60-SPR & SPS Series

Features

- Ideally suited for products that must conform to FCC part 15 regulations
- Metal cased miniature filter offers high performance
- Meets over voltage of IEC 664 category II and complies with IEC 950
- Uses IEC connector that meets most safety standards
- Snap-in style saves labor and hardware inventory
- Solder lug and fast-on tab terminations available
- Operating temperature: -25°C to +85°C (including temperature rise, see graph on page PF33)
- UL approved low leakage version also available



Tested and found to be IAW VDE 0565 Part 3.



Applications

- Digital equipment
- Personal computers and peripherals
- Measuring instruments
- Monitor and display units

Specifications

Model*	Rated Voltage (@ 50/60Hz)	Rated Current	Leakage Current (Max.)	Capacitance		Inductance (L ₁)	Temperature Rise (Max.)
				C _Y	C _X		
60-XXX-010-3-2	250VAC	1A	0.35mA	2200pF ± 20%	.022uF ± 20%	6.0mH	30°C
60-XXX-010-3-4				.047uF ± 20%			
60-XXX-010-5-2			0.50mA	3300pF ± 20%	.022uF ± 20%		
60-XXX-010-5-4			.047uF ± 20%				
60-XXX-020-3-2	250VAC	2A	0.35mA	2200pF ± 20%	.022uF ± 20%	2.4mH	30°C
60-XXX-020-3-4				.047uF ± 20%			
60-XXX-020-5-2			0.50mA	3300pF ± 20%	.022uF ± 20%		
60-XXX-020-5-4			.047uF ± 20%				
60-XXX-030-3-2	250VAC	3A	0.35mA	2200pF ± 20%	.022uF ± 20%	1.2mH	30°C
60-XXX-030-3-4				.047uF ± 20%			
60-XXX-030-5-2			0.50mA	3300pF ± 20%	.022uF ± 20%		
60-XXX-030-5-4			.047uF ± 20%				
60-XXX-060-3-2	250VAC	6A	0.35mA	2200pF ± 20%	.022uF ± 20%	0.53mH	45°C
60-XXX-060-3-4				.047uF ± 20%			
60-XXX-060-5-2			0.50mA	3300pF ± 20%	.022uF ± 20%		
60-XXX-060-5-4			.047uF ± 20%				
60-XXX-100-3-2	250VAC	10A	0.35mA	2200pF ± 20%	.022uF ± 20%	0.26mH	45°C
60-XXX-100-5-2			0.50mA	3300pF ± 20%			
60-SPR-150-3-11	250VAC	15A	0.35mA	2200pF ± 20%	.1uF ± 20%	0.15mH	45°C

Note: Test voltage: 1500VAC one minute, line to ground
 Insulation resistance: 300 Mohm min. at 500VDC
 Voltage drop: 1V max. at rated current
 Weight: 45g
 Input: Compatible with IEC-320

* Substitute SPR or SPS for XXX
 60-SPR - Fast-on terminals
 60-SPS - Solder lug terminals

Circuit Diagram

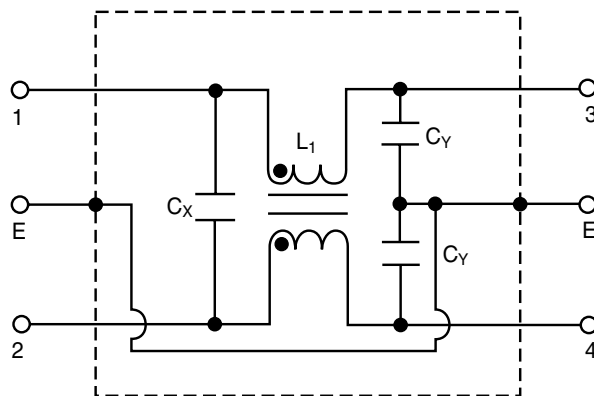

Power Entry Modules Snap-in Mount

60-SPR & SPS Series

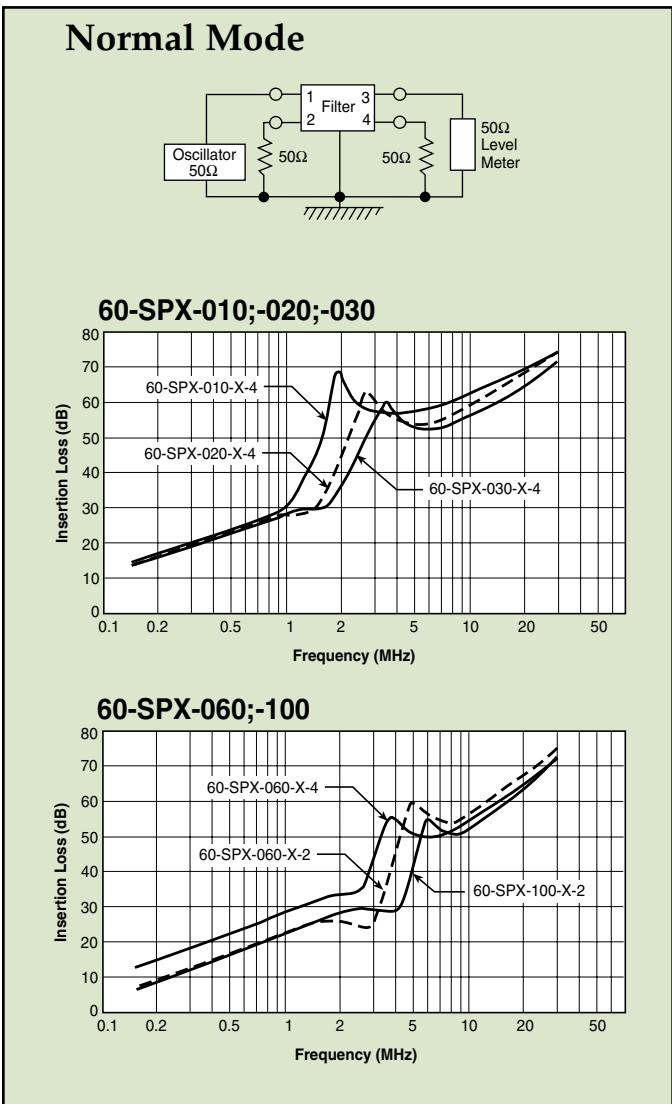
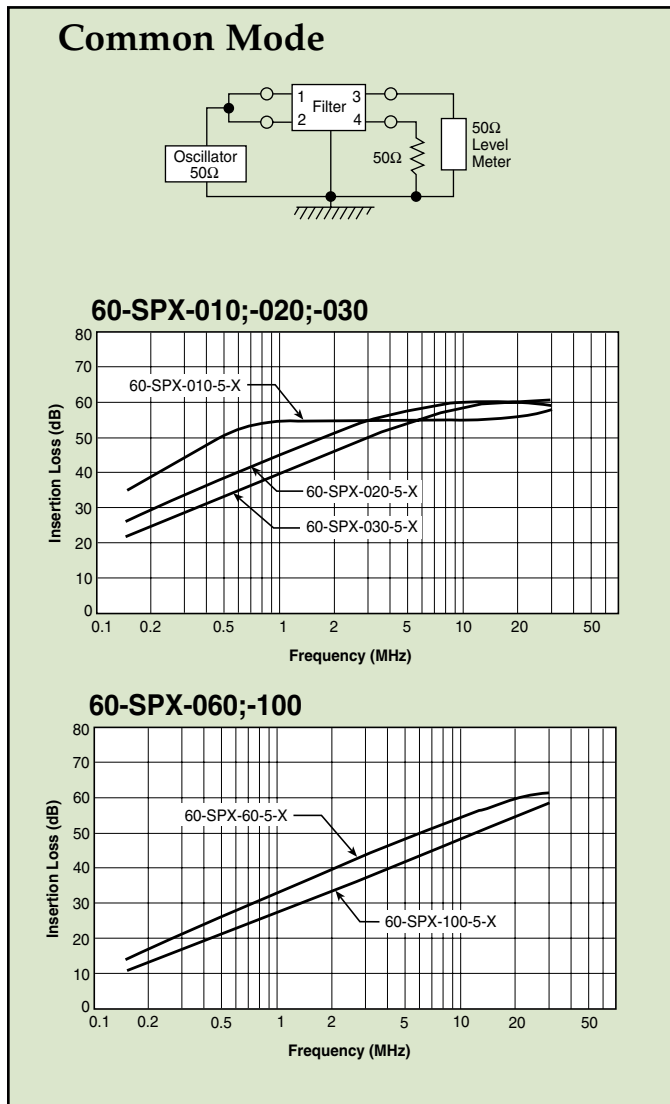
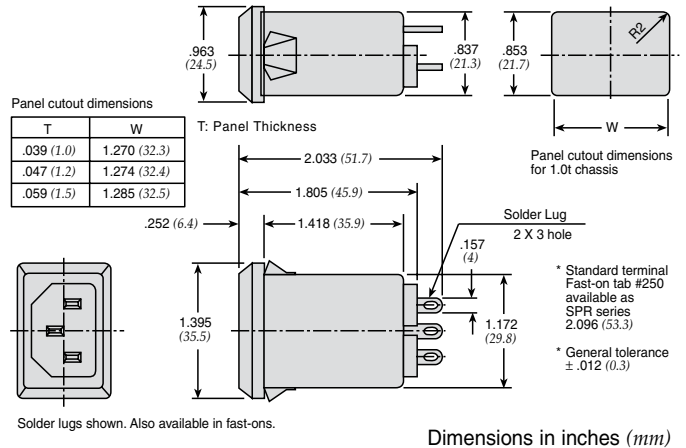
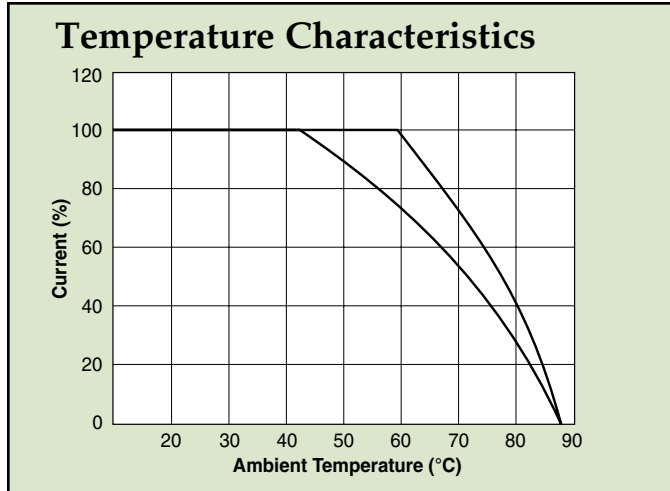

Fused Filtered Power Entry Modules

For General Purpose Applications

64-65-BFF/64-65-BFS Series



Tested and found to be IAW VDE 0565 Part 3.

Features

- North American and Metric fuse holders available
- Fuse holder provides effective EMI suppression of common and differential mode
- Suitable for products that must conform to FCC and FTZ requirements
- Meets over voltage category II of IEC 664 and complies with IEC 950
- Fast-on terminals or solder lug terminals
- Metal case provides effective EMI shielding
- Operating temperature: -25°C to +85°C (including temperature rise, see graph on page PF35)

Applications

- Computers and peripheral equipment
- Electronic equipment
- Digital equipment
- Measuring and testing instruments
- Telecommunications equipment

Specifications

Model*	Rated Voltage (@ 50/60Hz)	Rated Current	Leakage Current (Max.)	Capacitance		Inductance (L ₁)	Temperature Rise (Max.)
				C _Y	C _X		
64-XXX-020-3-11	250VAC	2A	0.35mA	2200pF ± 20%	0.1uF	6.5mH	40°C
64-XXX-020-5-11			0.50mA	3300pF ± 20%			
64-XXX-020-3-12			0.35mA	2200pF ± 20%	0.22uF		
64-XXX-020-5-12			0.50mA	3300pF ± 20%			
64-XXX-040-3-11	250VAC	4A	0.35mA	2200pF ± 20%	0.1uF	4.2mH	45°C
64-XXX-040-5-11			0.50mA	3300pF ± 20%			
64-XXX-040-3-12			0.35mA	2200pF ± 20%	0.22uF		
64-XXX-040-5-12			0.50mA	3300pF ± 20%			
64-XXX-060-3-11	250VAC	6A	0.35mA	2200pF ± 20%	0.1uF	1.6mH	45°C
64-XXX-060-5-11			0.50mA	3300pF ± 20%			
64-XXX-060-3-12			0.35mA	2200pF ± 20%	0.22uF		
64-XXX-060-5-12			0.50mA	3300pF ± 20%			
65-XXX-020-3-11	125VAC	2A	0.20mA	2200pF ± 20%	0.1uF	6.5mH	40°C
65-XXX-020-5-11			0.25mA	3300pF ± 20%			
65-XXX-020-3-12			0.20mA	2200pF ± 20%	0.22uF		
65-XXX-020-5-12			0.25mA	3300pF ± 20%			
65-XXX-040-3-11	125VAC	4A	0.20mA	2200pF ± 20%	0.1uF	4.2mH	45°C
65-XXX-040-5-11			0.25mA	3300pF ± 20%			
65-XXX-040-3-12			0.20mA	2200pF ± 20%	0.22uF		
65-XXX-040-5-12			0.25mA	3300pF ± 20%			
65-XXX-060-3-11	125VAC	6A	0.20mA	2200pF ± 20%	0.1uF	1.6mH	45°C
65-XXX-060-5-11			0.25mA	3300pF ± 20%			
65-XXX-060-3-12			0.20mA	2200pF ± 20%	0.22uF		
65-XXX-060-5-12			0.25mA	3300pF ± 20%			

Note: Test Voltage 1500VAC one minute, line to ground
Insulation Resistance: 300 M min. at 500VDC
F(S) = Fast-on or (Solder lug terminals)

Voltage Drop: 1V max. at rated current
Weight: 78g
Inlet: Compatible with IEC-320

* Substitute BFF or BFS for XXX
BFF - Fast-on terminals
BFS - Solder lug terminals



Circuit Diagram

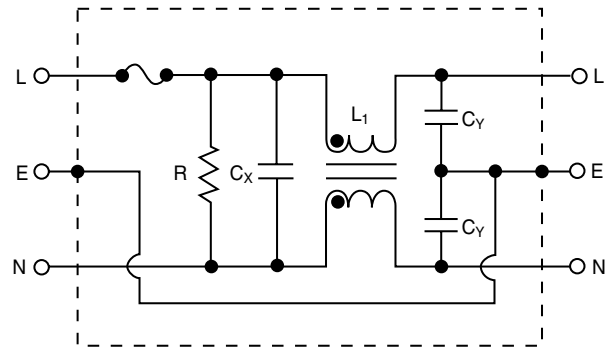

Fused Filtered Power Entry Modules

For General Purpose Applications

64-65-BFF/64-65-BFS Series

Temperature Characteristics

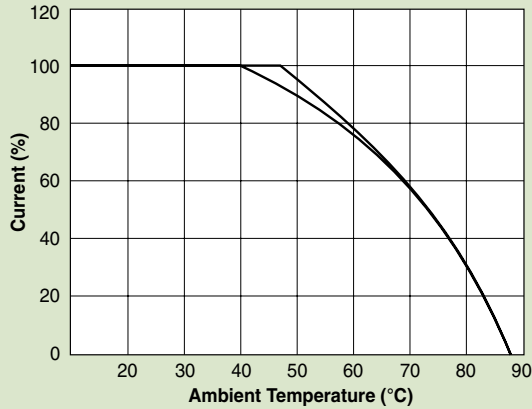

Dimensions 64/65-BFF Series

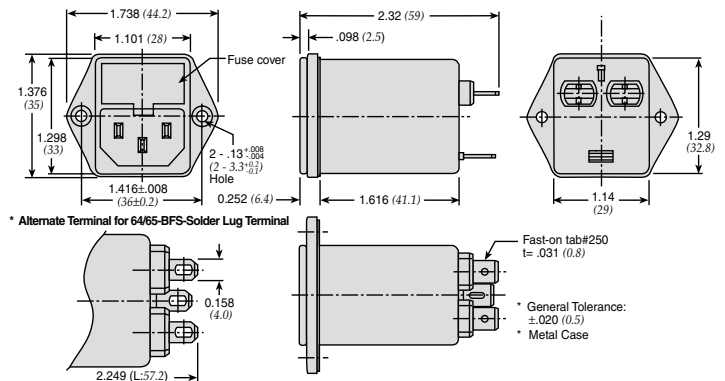

Dimensions in inches (mm)

Common Mode

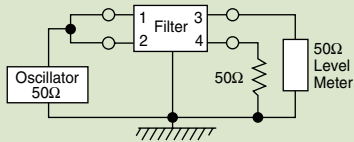

0.50 mA Leakage Versions

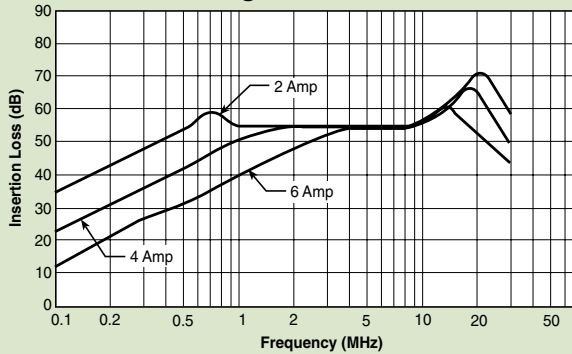

0.35 mA Leakage Versions

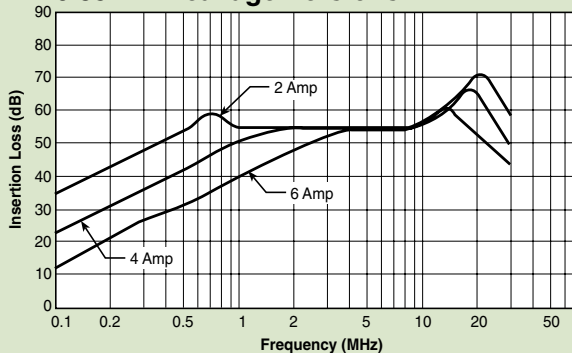

Normal Mode

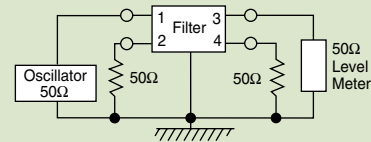

0.50 mA Leakage Versions

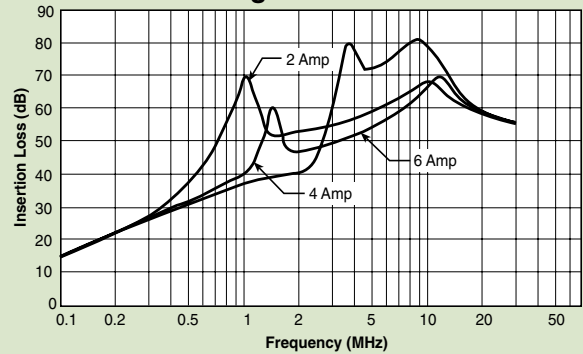

0.35 mA Leakage Versions

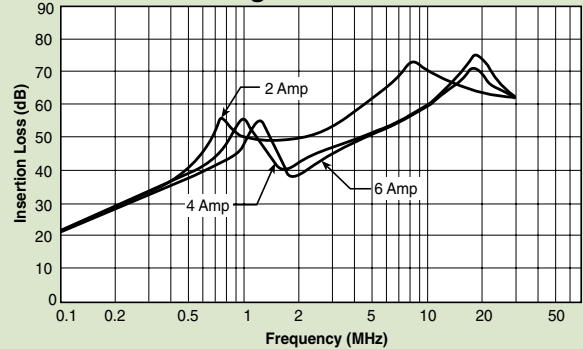

Fused Filtered Power Entry Modules

For Medical or General Purpose Applications

66-67-BFF/66-67-BFS Series



Tested and found to be IAW VDE 0565 Part 3.

Features

- Metric and North American fuse holders available
- Fuse holder provides effective EMI suppression of common and differential mode
- Suitable for products that must conform to FCC and FTZ requirements
- Meets over voltage category II of IEC 664 and complies with IEC 950
- Fast-on terminations or solder lug terminations
- Metal case provides effective EMI shielding
- Provides susceptibility protection without the leakage current associated with line-to-ground capacitance
- Reduces the line to ground capacitance in order to meet patient care requirements
- Operating temperature: -25°C to +85°C (including temperature rise, see graph on page PF37)



Applications

- Medical equipment
- Electronic equipment
- Digital equipment
- Industrial equipment
- Telecommunications equipment
- Measuring and testing instruments
- Personal computers and peripherals

Circuit Diagrams

66/67-BFF(S)-XXX-1-X Filter

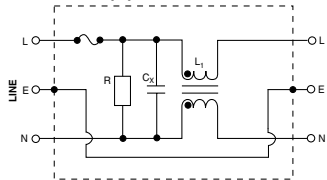

66/67-BFF(S)-XXX-0-X and 66/67-BFF(S)-XXX-4-X Filters

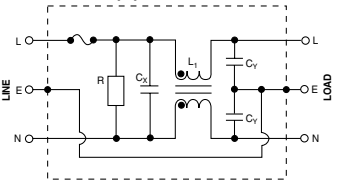

Specifications

Model*	Rated Voltage (@ 50/60Hz)	Rated Current	Leakage Current (Max.)	Capacitance		Inductance (L ₁)	Temperature Rise (Max.)	
				C _V	C _X			
66-XXX-020-1-11	250VAC	2A	0.01mA	none	0.1uF	6.5mH	40°C	
66-XXX-020-1-12					0.22uF			
66-XXX-020-0-11					0.075mA			330pF ± 20%
66-XXX-020-4-11					0.1mA			470pF ± 20%
66-XXX-020-0-12					0.075mA			330pF ± 20%
66-XXX-020-4-12					0.1mA			470pF ± 20%
66-XXX-040-1-11	250VAC	4A	0.01mA	none	0.1uF	2.4mH	45°C	
66-XXX-040-1-12					0.22uF			
66-XXX-040-0-11					0.075mA			330pF ± 20%
66-XXX-040-4-11					0.1mA			470pF ± 20%
66-XXX-040-0-12					0.075mA			330pF ± 20%
66-XXX-040-4-12					0.1mA			470pF ± 20%
66-XXX-060-1-11	250VAC	6A	0.01mA	none	0.1uF	1.6mH	45°C	
66-XXX-060-1-12					0.22uF			
66-XXX-060-0-11					0.075mA			330pF ± 20%
66-XXX-060-4-11					0.1mA			470pF ± 20%
66-XXX-060-0-12					0.075mA			330pF ± 20%
66-XXX-060-4-12					0.1mA			470pF ± 20%
67-XXX-020-1-11	125VAC	2A	0.005mA	none	0.1uF	6.5mH	40°C	
67-XXX-020-1-12					0.22uF			
67-XXX-020-0-11					0.035mA			330pF ± 20%
67-XXX-020-4-11					0.05mA			470pF ± 20%
67-XXX-020-0-12					0.035mA			330pF ± 20%
67-XXX-020-4-12					0.05mA			470pF ± 20%
67-XXX-040-1-11	125VAC	4A	0.005mA	none	0.1uF	2.4mH	45°C	
67-XXX-040-1-12					0.22uF			
67-XXX-040-0-11					0.035mA			330pF ± 20%
67-XXX-040-4-11					0.05mA			470pF ± 20%
67-XXX-040-0-12					0.035mA			330pF ± 20%
67-XXX-040-4-12					0.05mA			470pF ± 20%
67-XXX-060-1-11	125VAC	6A	0.005mA	none	0.1uF	1.6mH	45°C	
67-XXX-060-1-12					0.22uF			
67-XXX-060-0-11					0.035mA			330pF ± 20%
67-XXX-060-4-11					0.05mA			470pF ± 20%
67-XXX-060-0-12					0.035mA			330pF ± 20%
67-XXX-060-4-12					0.05mA			470pF ± 20%

Note: Test Voltage 1500VAC one minute, line to ground
Insulation Resistance: 300 M min. at 500VDC
F(S) = Fast-on or (Solder lug terminals)

Voltage Drop: 1V max. at rated current
Weight: 78g
Inlet: Compatible with IEC-320

* Substitute BFF or BFS for XXX
BFF - Fast-on terminals
BFS - Solder lug terminals

Fused Filtered Power Entry Modules

For Medical or General Purpose Applications

66-67-BFF/66-67-BFS Series

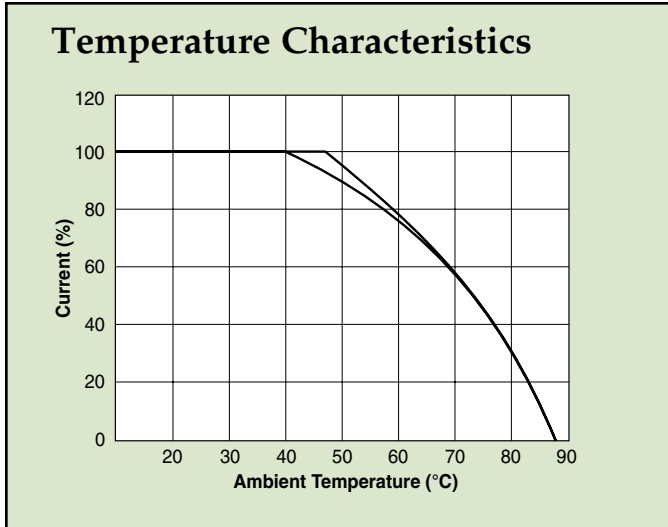

Dimensions

66-67-BFF/66-67-BFS Series

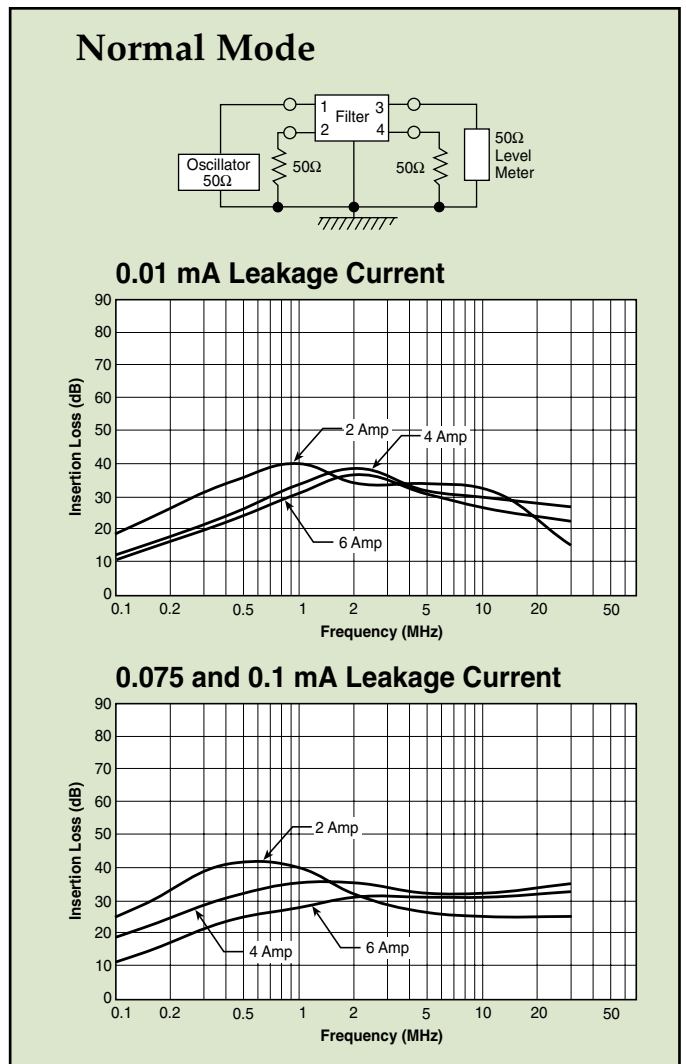
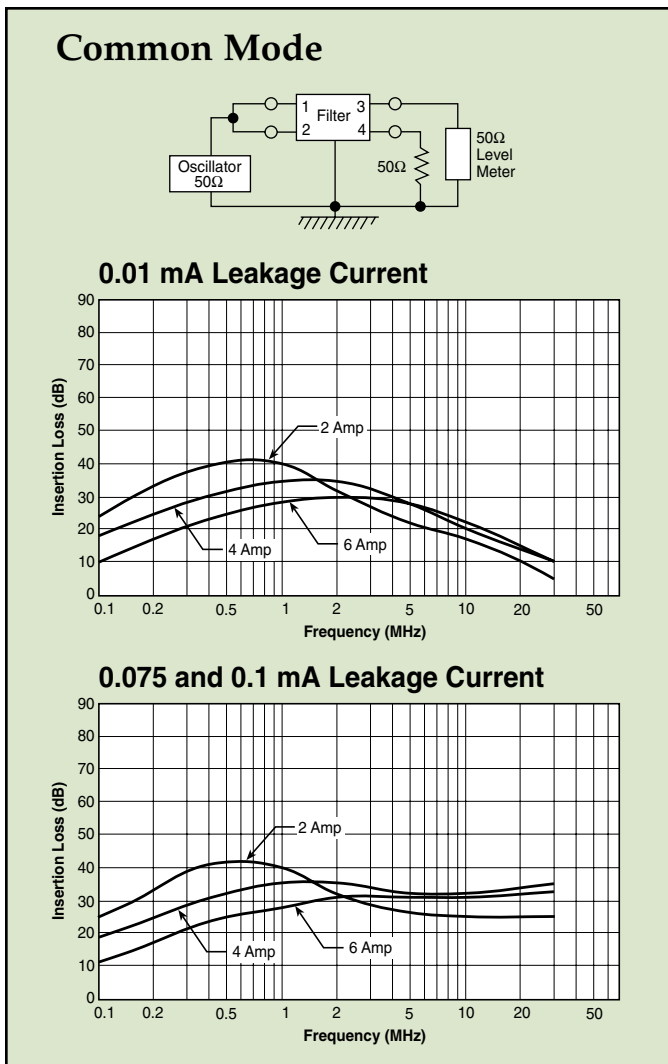
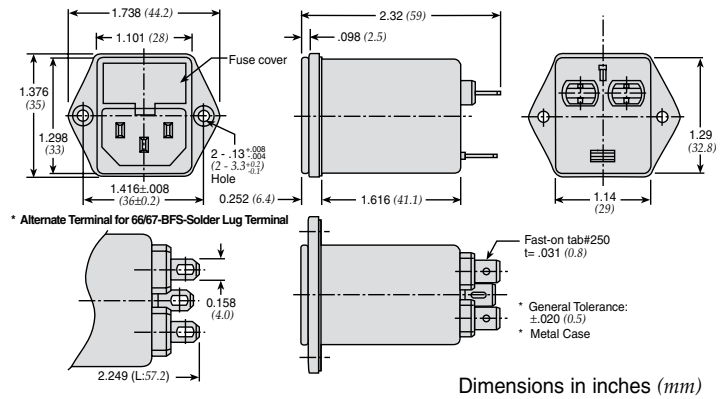

Switched and Fused Filtered Power Entry Modules

For General Purpose Applications

64-65-BSF/64-65-SSF Series

Features

- North American and Metric fuse holders available
- Fuse holder and double pole power ON/OFF switch provided in a convenient/compact package
- Suitable for products that must conform to FCC and FTZ requirements
- Meets over voltage category II of IEC 664 and complies with IEC 950
- Metal case provides effective EMI shielding
- Easy access fuse drawer with space for spare fuse
- Flange-mounted or snap-in styles available for quick mounting
- Operating temperature: -25°C to +85°C (including temperature rise, see graph on page PF39)



Tested and found to be IAW VDE 0565 Part 3.



Applications

- Computers and peripheral equipment
- Digital equipment
- Electronic equipment
- Measuring and testing instruments
- Telecommunications equipment

Circuit Diagram

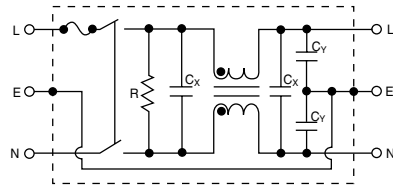

Specifications

Model*	Rated Voltage (@ 50/60Hz)	Rated Current	Leakage Current (Max.)	Capacitance			Inductance (L ₁)	Temperature Rise (Max.)
				C _Y	C _{X1}	C _{X2}		
64-XXX-020-3-12	250VAC	2A	0.35mA	2200pF	0.22uF	NONE	10.5mH	45°C
64-XXX-020-3-04						0.22uF		
64-XXX-020-3-14						NONE		
64-XXX-020-3-06			0.22uF					
64-XXX-020-5-12			0.50mA	3300pF	0.22uF	NONE		
64-XXX-020-5-04						0.22uF		
64-XXX-020-5-14	NONE							
64-XXX-020-5-06	250VAC	4A	0.35mA	2200pF	0.22uF	NONE	4.2mH	45°C
64-XXX-040-3-04						0.22uF		
64-XXX-040-3-14						NONE		
64-XXX-040-3-06			0.22uF					
64-XXX-040-5-12			0.50mA	3300pF	0.22uF	NONE		
64-XXX-040-5-04						0.22uF		
64-XXX-040-5-14	NONE							
64-XXX-040-5-06	250VAC	6A	0.35mA	2200pF	0.22uF	NONE	1.6mH	45°C
64-XXX-060-3-04						0.22uF		
64-XXX-060-3-14						NONE		
64-XXX-060-3-06			0.22uF					
64-XXX-060-5-12			0.50mA	3300pF	0.22uF	NONE		
64-XXX-060-5-04						0.22uF		
64-XXX-060-5-14	NONE							
64-XXX-060-5-06	125VAC	2A	0.20mA	2200pF	0.22uF	NONE	10.5mH	45°C
65-XXX-020-3-04						0.22uF		
65-XXX-020-3-14						NONE		
65-XXX-020-3-06			0.22uF					
65-XXX-020-5-12			0.25mA	3300pF	0.22uF	NONE		
65-XXX-020-5-04						0.22uF		
65-XXX-020-5-14	NONE							
65-XXX-020-5-06	125VAC	4A	0.20mA	2200pF	0.22uF	NONE	4.2mH	45°C
65-XXX-040-3-04						0.22uF		
65-XXX-040-3-14						NONE		
65-XXX-040-3-06			0.22uF					
65-XXX-040-5-12			0.25mA	3300pF	0.22uF	NONE		
65-XXX-040-5-04						0.22uF		
65-XXX-040-5-14	NONE							
65-XXX-040-5-06	125VAC	6A	0.20mA	2200pF	0.22uF	NONE	1.6mH	45°C
65-XXX-060-3-04						0.22uF		
65-XXX-060-3-14						NONE		
65-XXX-060-3-06			0.22uF					
65-XXX-060-5-12			0.25mA	3300pF	0.22uF	NONE		
65-XXX-060-5-04						0.22uF		
65-XXX-060-5-14	NONE							
65-XXX-060-5-06	125VAC	2A	0.20mA	2200pF	0.22uF	NONE	10.5mH	45°C
65-XXX-020-3-04						0.22uF		
65-XXX-020-3-14						NONE		
65-XXX-020-3-06			0.22uF					
65-XXX-020-5-12			0.25mA	3300pF	0.22uF	NONE		
65-XXX-020-5-04						0.22uF		
65-XXX-020-5-14	NONE							
65-XXX-020-5-06	125VAC	4A	0.20mA	2200pF	0.22uF	NONE	4.2mH	45°C
65-XXX-040-3-04						0.22uF		
65-XXX-040-3-14						NONE		
65-XXX-040-3-06			0.22uF					
65-XXX-040-5-12			0.25mA	3300pF	0.22uF	NONE		
65-XXX-040-5-04						0.22uF		
65-XXX-040-5-14	NONE							
65-XXX-040-5-06	125VAC	6A	0.20mA	2200pF	0.22uF	NONE	1.6mH	45°C
65-XXX-060-3-04						0.22uF		
65-XXX-060-3-14						NONE		
65-XXX-060-3-06			0.22uF					
65-XXX-060-5-12			0.25mA	3300pF	0.22uF	NONE		
65-XXX-060-5-04						0.22uF		
65-XXX-060-5-14	NONE							
65-XXX-060-5-06	125VAC	2A	0.20mA	2200pF	0.22uF	NONE	10.5mH	45°C
65-XXX-020-3-04						0.22uF		
65-XXX-020-3-14						NONE		
65-XXX-020-3-06			0.22uF					
65-XXX-020-5-12			0.25mA	3300pF	0.22uF	NONE		
65-XXX-020-5-04						0.22uF		
65-XXX-020-5-14	NONE							
65-XXX-020-5-06	125VAC	4A	0.20mA	2200pF	0.22uF	NONE	4.2mH	45°C
65-XXX-040-3-04						0.22uF		
65-XXX-040-3-14						NONE		
65-XXX-040-3-06			0.22uF					
65-XXX-040-5-12			0.25mA	3300pF	0.22uF	NONE		
65-XXX-040-5-04						0.22uF		
65-XXX-040-5-14	NONE							
65-XXX-040-5-06	125VAC	6A	0.20mA	2200pF	0.22uF	NONE	1.6mH	45°C
65-XXX-060-3-04						0.22uF		
65-XXX-060-3-14						NONE		
65-XXX-060-3-06			0.22uF					
65-XXX-060-5-12			0.25mA	3300pF	0.22uF	NONE		
65-XXX-060-5-04						0.22uF		
65-XXX-060-5-14	NONE							
65-XXX-060-5-06	125VAC	2A	0.20mA	2200pF	0.22uF	NONE	10.5mH	45°C
65-XXX-020-3-04						0.22uF		
65-XXX-020-3-14						NONE		
65-XXX-020-3-06			0.22uF					
65-XXX-020-5-12			0.25mA	3300pF	0.22uF	NONE		
65-XXX-020-5-04						0.22uF		
65-XXX-020-5-14	NONE							
65-XXX-020-5-06	125VAC	4A	0.20mA	2200pF	0.22uF	NONE	4.2mH	45°C
65-XXX-040-3-04						0.22uF		
65-XXX-040-3-14						NONE		
65-XXX-040-3-06			0.22uF					
65-XXX-040-5-12			0.25mA	3300pF	0.22uF	NONE		
65-XXX-040-5-04						0.22uF		
65-XXX-040-5-14	NONE							
65-XXX-040-5-06	125VAC	6A	0.20mA	2200pF	0.22uF	NONE	1.6mH	45°C
65-XXX-060-3-04						0.22uF		
65-XXX-060-3-14						NONE		
65-XXX-060-3-06			0.22uF					
65-XXX-060-5-12			0.25mA	3300pF	0.22uF	NONE		
65-XXX-060-5-04						0.22uF		
65-XXX-060-5-14	NONE							
65-XXX-060-5-06	125VAC	2A	0.20mA	2200pF	0.22uF	NONE	10.5mH	45°C
65-XXX-020-3-04						0.22uF		
65-XXX-020-3-14						NONE		
65-XXX-020-3-06			0.22uF					
65-XXX-020-5-12			0.25mA	3300pF	0.22uF	NONE		
65-XXX-020-5-04						0.22uF		
65-XXX-020-5-14	NONE							
65-XXX-020-5-06	125VAC	4A	0.20mA	2200pF	0.22uF	NONE	4.2mH	45°C
65-XXX-040-3-04						0.22uF		
65-XXX-040-3-14						NONE		
65-XXX-040-3-06			0.22uF					
65-XXX-040-5-12			0.25mA	3300pF	0.22uF	NONE		
65-XXX-040-5-04						0.22uF		
65-XXX-040-5-14	NONE							
65-XXX-040-5-06	125VAC	6A	0.20mA	2200pF	0.22uF	NONE	1.6mH	45°C
65-XXX-060-3-04						0.22uF		
65-XXX-060-3-14						NONE		
65-XXX-060-3-06			0.22uF					
65-XXX-060-5-12			0.25mA	3300pF	0.22uF	NONE		
65-XXX-060-5-04						0.22uF		
65-XXX-060-5-14	NONE							
65-XXX-060-5-06	125VAC	2A	0.20mA	2200pF	0.22uF	NONE	10.5mH	45°C
65-XXX-020-3-04						0.22uF		
65-XXX-020-3-14						NONE		
65-XXX-020-3-06			0.22uF					
65-XXX-020-5-12			0.25mA	3300pF	0.22uF	NONE		
65-XXX-020-5-04						0.22uF		
65-XXX-020-5-14	NONE							
65-XXX-020-5-06	125VAC	4A	0.20mA	2200pF	0.22uF	NONE	4.2mH	45°C
65-XXX-040-3-04						0.22uF		
65-XXX-040-3-14						NONE		
65-XXX-040-3-06			0.22uF					
65-XXX-040-5-12			0.25mA	3300pF	0.22uF	NONE		
65-XXX-040-5-04						0.22uF		
65-XXX-040-5-14	NONE							
65-XXX-040-5-06	125VAC	6A	0.20mA	2200pF	0.22uF	NONE	1.6mH	45°C
65-XXX-060-3-04						0.22uF		
65-XXX-060-3-14						NONE		
65-XXX-060-3-06			0.22uF					
65-XXX-060-5-12			0.25mA	3300pF	0.22uF	NONE		
65-XXX-060-5-04						0.22uF		
65-XXX-060-5-14	NONE							

Note: Test Voltage 1500VAC one minute, line to ground
Insulation Resistance: 300 M min. at 500VDC
B(S) = Bolt-in terminals or (Snap-in terminals)

Voltage Drop: 1V max. at rated current
Weight: 130g
Inlet: Compatible with IEC-320

* Substitute BSF or SSF for XXX
BSF - Bolt-in switched and fused
SSF - Snap-in switched and fused

Switched and Fused Filtered Power Entry Modules

For General Purpose Applications

Temperature Characteristics

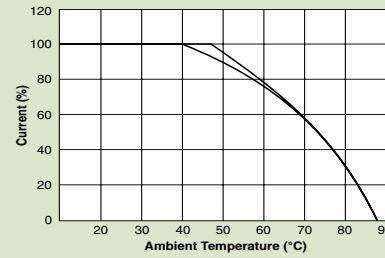

Dimensions

64/65-BSF Series

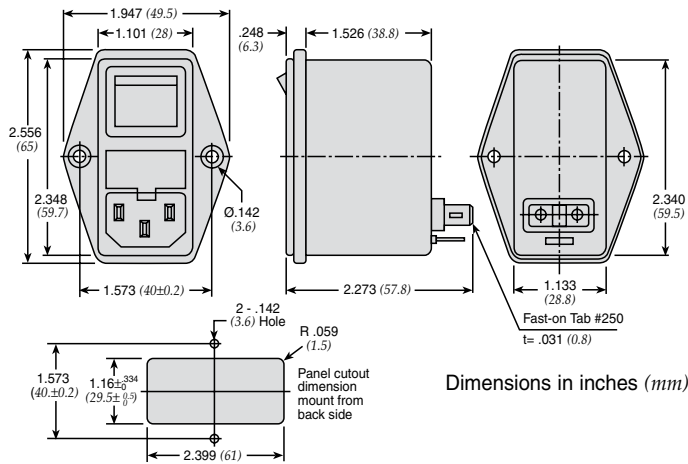

64/65-SSF Series

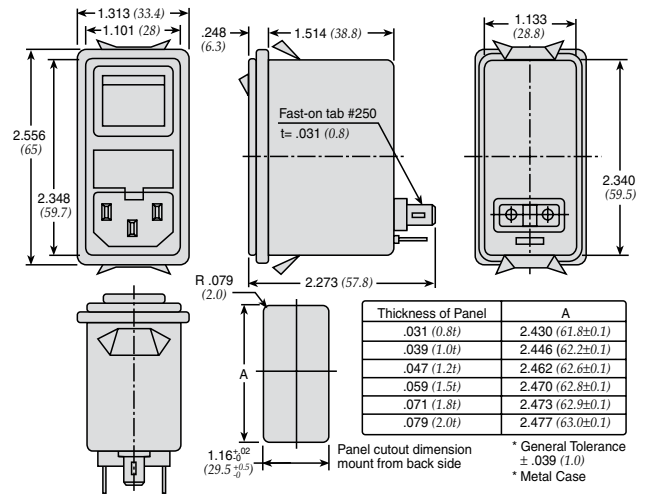

Common Mode

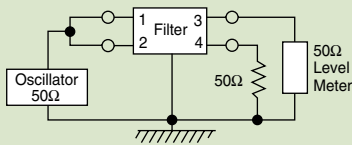

0.35 mA Leakage Versions

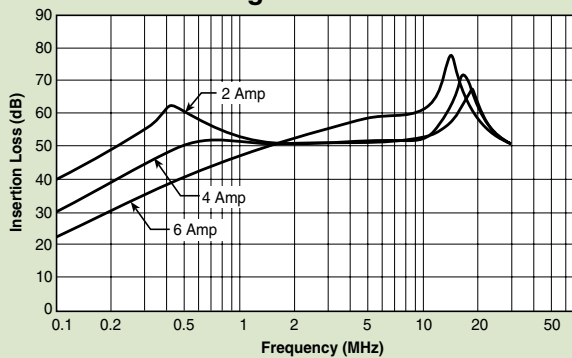

0.50 mA Leakage Versions

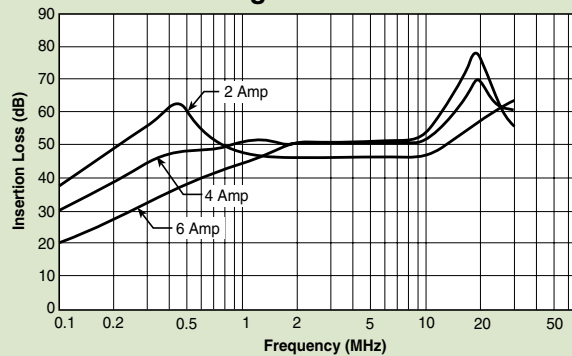

Normal Mode

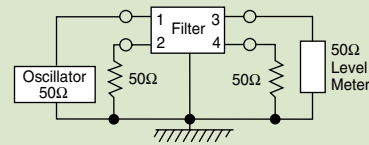

64/65-B(S)SF-*-02(04,06)

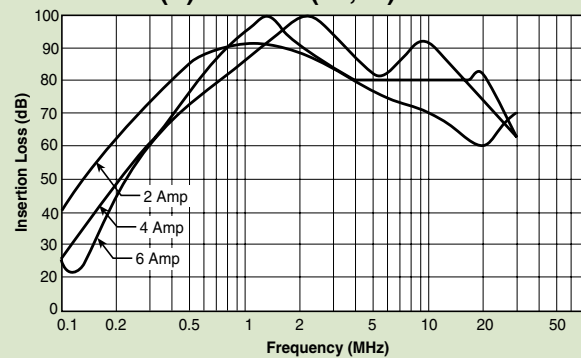

64/65-B(S)SF-*-11(12,14)

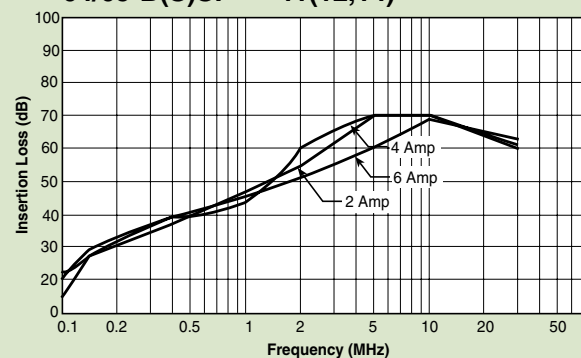

Switched and Fused Filtered Power Entry Modules

For Medical or General Purpose Applications

66-67-BSF/66-67-SSF Series



Tested and found to be IAW VDE 0565 Part 3

Features

- Metric and North American fuse holders available
- Fuse holder and a double pole power ON/OFF switch provides a convenient/compact package
- Suitable for products that must conform to FCC and FTZ requirements
- Meets over voltage category II of IEC 664 and complies with IEC 950
- Provides susceptibility protection without the leakage current associated with line-to-ground capacitors
- Designed to meet requirements for non-patient and patient care equipment
- Metal case provides effective EMI shielding
- Easy access fuse drawer - space for spare fuse
- Flange-mounted or snap-in styles available for quick mounting
- Operating temperature: -25°C to +85°C (including temperature rise, see graph on page PF41)

Specifications

Model*	Rated Voltage 50/60Hz	Rated Current	Leakage Current (Max.)	Capacitance			Temp. Induct. (L ₁)	Rise (Max.)				
				C _Y	C _{X1}	C _{X2}						
66-XXX-020-0-12	250 VAC	2A	.075mA	330pF	0.22uF	NONE	10.5mH	40°C				
66-XXX-020-0-04					0.22uF	NONE						
66-XXX-020-0-14					0.47uF	NONE						
66-XXX-020-0-06					0.22uF	NONE						
66-XXX-020-1-12					0.22uF	NONE						
66-XXX-020-1-04					0.22uF	NONE						
66-XXX-020-1-14			.01mA	NONE	NONE	0.22uF			NONE			
66-XXX-020-1-04						0.22uF			NONE			
66-XXX-020-1-14						0.47uF			NONE			
66-XXX-020-1-06						0.22uF			NONE			
66-XXX-020-4-12						0.1mA			470pF	470pF	0.22uF	NONE
66-XXX-020-4-04											0.22uF	NONE
66-XXX-020-4-14		0.47uF	NONE									
66-XXX-020-4-06		0.22uF	NONE									
66-XXX-040-0-12		4A	.075mA	330pF	0.22uF		NONE	4.2mH			45°C	
66-XXX-040-0-04					0.22uF		NONE					
66-XXX-040-0-14					0.47uF	NONE						
66-XXX-040-0-06					0.22uF	NONE						
66-XXX-040-1-12					0.22uF	NONE						
66-XXX-040-1-04					0.22uF	NONE						
66-XXX-040-1-14			.01mA	NONE	NONE	0.47uF	NONE					
66-XXX-040-1-06						0.22uF	NONE					
66-XXX-040-4-12						.01mA	470pF		470pF	0.22uF		NONE
66-XXX-040-4-04										0.22uF		NONE
66-XXX-040-4-14	0.47uF									NONE		
66-XXX-040-4-06	0.22uF									NONE		
66-XXX-060-0-12	6A	.075mA	330pF	0.22uF	NONE			1.6mH		45°C		
66-XXX-060-0-04				0.22uF	NONE							
66-XXX-060-0-14				0.47uF	NONE							
66-XXX-060-0-06				0.22uF	NONE							
66-XXX-060-1-12				0.22uF	NONE							
66-XXX-060-1-04				0.22uF	NONE							
66-XXX-060-1-14		.01mA	NONE	NONE	0.47uF	NONE						
66-XXX-060-1-06					0.22uF	NONE						
66-XXX-060-4-12					0.1mA	470pF	470pF		0.22uF		NONE	
66-XXX-060-4-04									0.22uF		NONE	
66-XXX-060-4-14									0.47uF		NONE	
66-XXX-060-4-06									0.22uF		NONE	



Applications

- Medical equipment
- Industrial equipment
- Telecommunications equipment
- Measuring and testing instruments
- Digital equipment (including switching power supplies)
- General purpose filter for susceptibility or high frequency "clean up" applications

Circuit Diagram

Note: C_{Y1} and C_{Y2} capacitors omitted on 66/67 B(S)F-XXX-1-X Filters

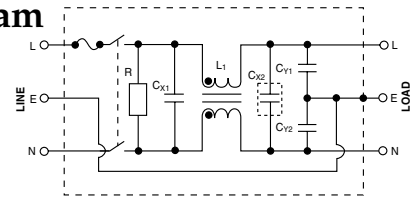

Model*	Rated Voltage 50/60Hz	Rated Current	Leakage Current (Max.)	Capacitance			Temp. Induct. (L ₁)	Rise (Max.)				
				C _Y	C _{X1}	C _{X2}						
67-XXX-020-0-12	250 VAC	2A	0.04mA	330pF	0.22uF	NONE	10.5mH	40°C				
67-XXX-020-0-04					0.22uF	NONE						
67-XXX-020-0-14					0.47uF	NONE						
67-XXX-020-0-06					0.22uF	NONE						
67-XXX-020-1-12					0.22uF	NONE						
67-XXX-020-1-04					0.22uF	NONE						
67-XXX-020-1-14			.005mA	NONE	NONE	0.47uF			NONE			
67-XXX-020-1-04						0.22uF			NONE			
67-XXX-020-1-14						0.47uF			NONE			
67-XXX-020-1-06						0.22uF			NONE			
67-XXX-020-4-12						0.05mA			470pF	470pF	0.22uF	NONE
67-XXX-020-4-04											0.22uF	NONE
67-XXX-020-4-14		0.47uF	NONE									
67-XXX-020-4-06		0.22uF	NONE									
67-XXX-040-0-12		4A	0.04mA	330pF	0.22uF		NONE	4.2mH			45°C	
67-XXX-040-0-04					0.22uF		NONE					
67-XXX-040-0-14					0.47uF	NONE						
67-XXX-040-0-06					0.22uF	NONE						
67-XXX-040-1-12					0.22uF	NONE						
67-XXX-040-1-04					0.22uF	NONE						
67-XXX-040-1-14			.005mA	NONE	NONE	0.47uF	NONE					
67-XXX-040-1-06						0.22uF	NONE					
67-XXX-040-4-12						0.05mA	470pF		470pF	0.22uF		NONE
67-XXX-040-4-04										0.22uF		NONE
67-XXX-040-4-14	0.47uF									NONE		
67-XXX-040-4-06	0.22uF									NONE		
67-XXX-060-0-12	6A	0.04mA	330pF	0.22uF	NONE			1.6mH		45°C		
67-XXX-060-0-04				0.22uF	NONE							
67-XXX-060-0-14				0.47uF	NONE							
67-XXX-060-0-06				0.22uF	NONE							
67-XXX-060-1-12				0.22uF	NONE							
67-XXX-060-1-04				0.22uF	NONE							
67-XXX-060-1-14		.005mA	NONE	NONE	0.47uF	NONE						
67-XXX-060-1-06					0.22uF	NONE						
67-XXX-060-4-12					0.05mA	470pF	470pF		0.22uF		NONE	
67-XXX-060-4-04									0.22uF		NONE	
67-XXX-060-4-14									0.47uF		NONE	
67-XXX-060-4-06									0.22uF		NONE	

Note: Test Voltage: 1500VAC one minute, line to ground
Insulation Resistance: 300 MΩ min. at 500VDC
Voltage Drop: 1V max. at rated current

Weight: 130g
Inlet: Compatible with IEC-320
B(S) = Bolt-in terminals or (Snap-in terminals)

* Substitute BSF or SSF for XXX
BSF - Bolt-In Switched and Fused
SSF - Snap-In Switched and Fused

Switched and Fused Filtered Power Entry Modules

For Medical or General Purpose Applications

Temperature Characteristics

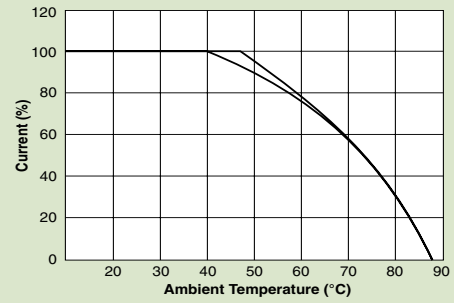

Dimensions

66/67-BSF Series

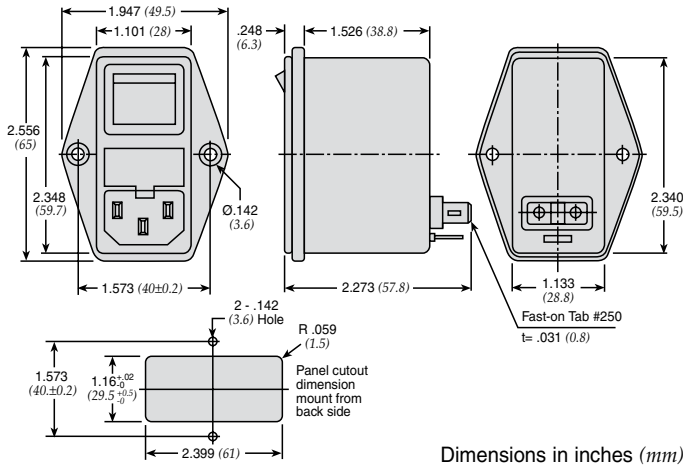

66/67-SSF Series

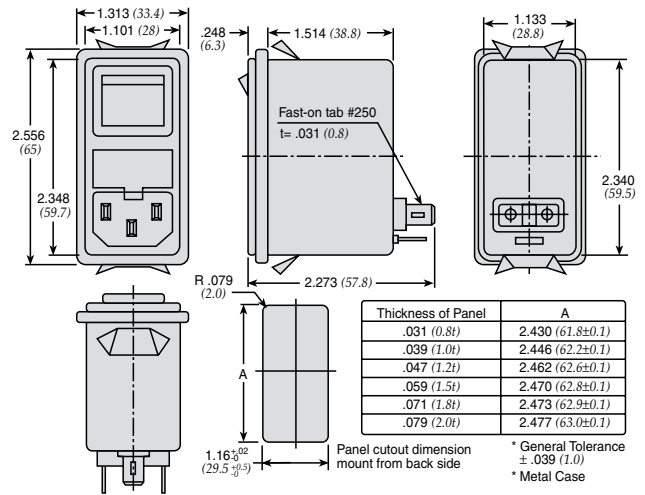

Common Mode

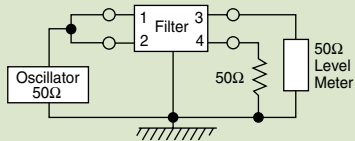

0.01 mA Leakage Current

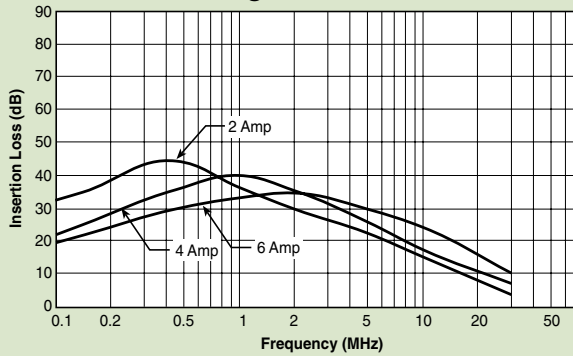

0.075 and 0.1 mA Leakage Current

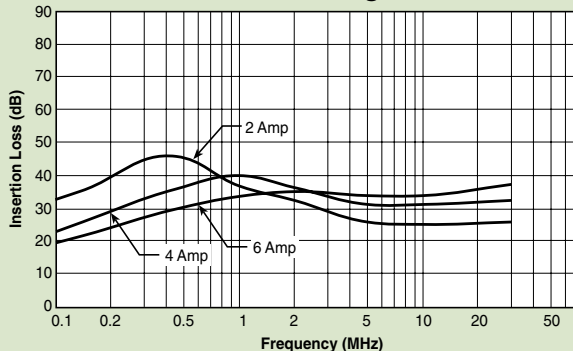

Normal Mode

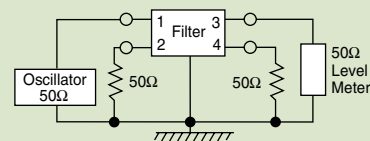

0.01 mA Leakage Current

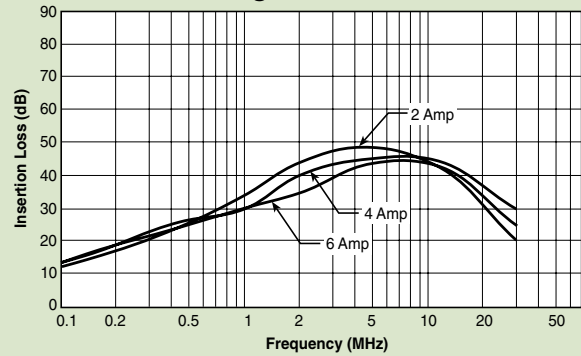

0.075 and 0.1 mA Leakage Current

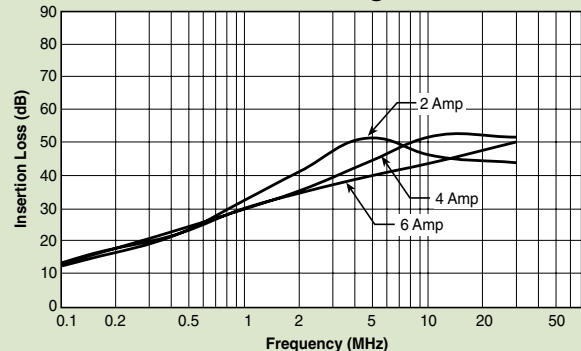

Switched and Fused Filtered Power Entry Modules

Dual Fuse for European Applications



68-BSF Series

Features

- Dual fuse for European applications
- Fuse holder and double pole power ON/OFF switch provides a convenient/compact package
- Suitable for products that must conform to FCC and FTZ requirements
- Meets over voltage category II of IEC 664 and complies with IEC 950
- Metal case provides effective EMI shielding
- IEC connector meets the safety standards of most certifying agencies
- Easy access fuse drawer
- Flange-mounted
- UL, CSA, and SEMKO approved
- Designed to be in accordance with VDE 0565, part 3
- Operating temperature: -25°C to +85°C (including temperature rise, see graph on page PF43)

Circuit Diagram

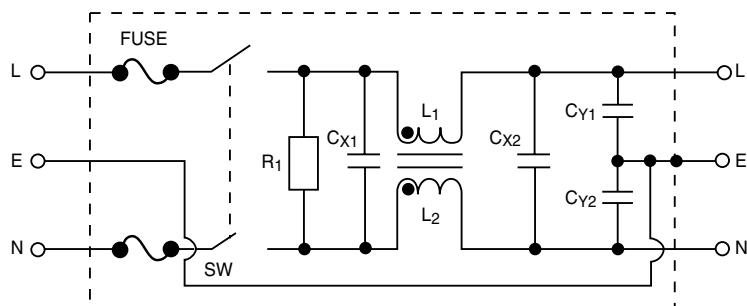

Applications

- Computers and peripheral equipment
- Electronic equipment
- Digital equipment
- Measuring and testing instruments
- Telecommunications equipment

Specifications

Model	Rated Voltage (@ 50/60Hz)	Rated Current	Leakage Current (Max.)	Capacitance				Inductance (L ₁)	Temperature Rise (Max.)
				C _{Y1}	C _{Y2}	C _{X1}	C _{X2}		
68-BSF-020-3-01	250VAC	2A	0.35mA	2200pF	2200pF	0.1uF	0.1uF	10.5mH	45°C
68-BSF-020-3-04						0.22uF	0.22uF		
68-BSF-040-3-01		4A				0.1uF	0.1uF	4.2mH	
68-BSF-040-3-04						0.22uF	0.22uF		
68-BSF-060-3-01		6A				0.1uF	0.1uF	1.6mH	
68-BSF-060-3-04						0.22uF	0.22uF		

Note: Test Voltage 1500VAC one minute, line to ground
 Insulation Resistance: 300 MΩ min. at 500VDC
 Voltage Drop: 1V max. at rated current
 Weight: 130g
 Inlet: Compatible with IEC-320
 B(S) = Bolt-in terminals

Switched and Fused Filtered Power Entry Modules

Dual Fuse for European Applications

68-BSF Series

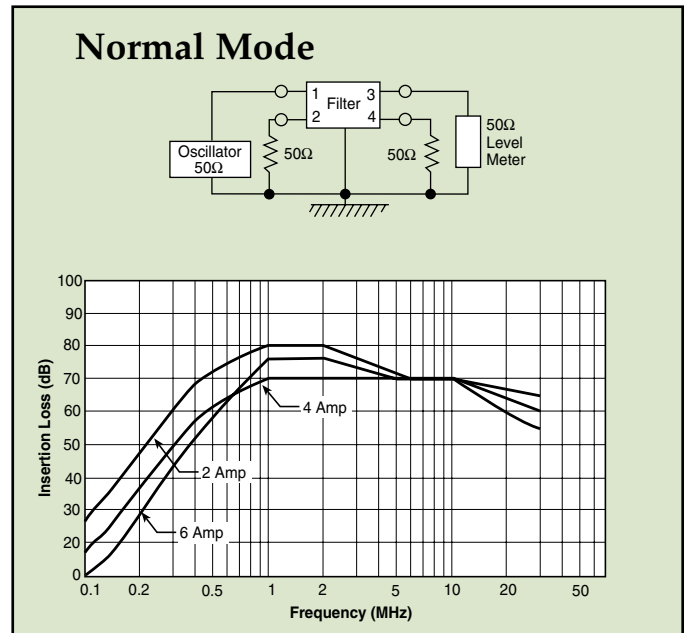
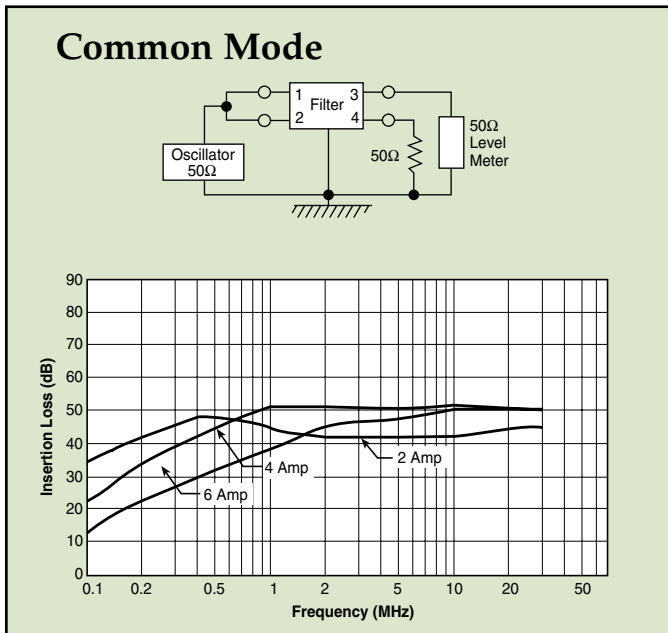
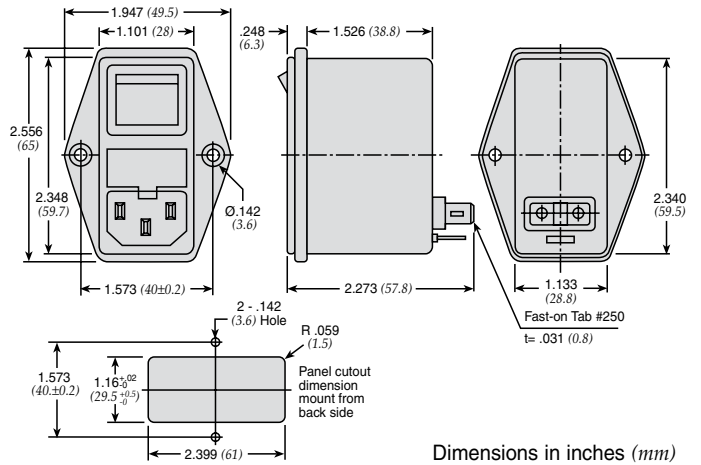
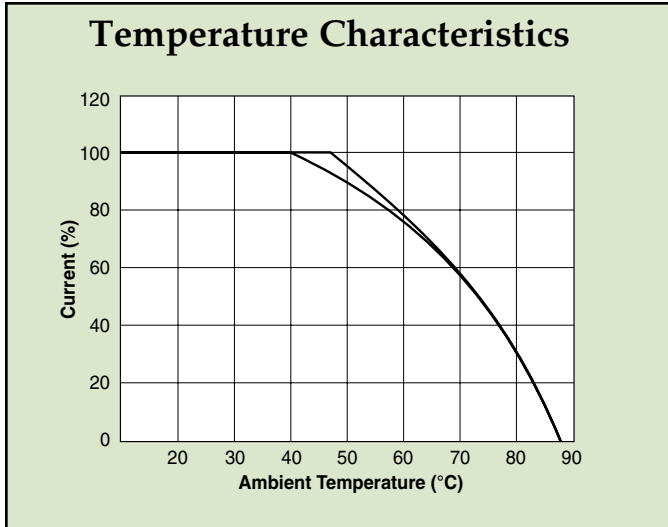

PCB Power Filters Miniature Printed Circuit Board

61-MPC Series



Tested and found to be
IAW VDE 0565 Part 3

Features

- Miniature general purpose PCB mounted filter
- Requires minimal PCB real estate space
- Low cost
- Designed for two wire cord systems
- For three wire cord systems, Y capacitors can be attached externally
- Operating temperature: -25°C to +85°C (including temperature rise, see graph on page PF45)

Applications

- Personal computers and peripherals
- Digital equipment
- Measuring instruments and medical equipment
- TV & VCR monitors and display units
- Home appliances

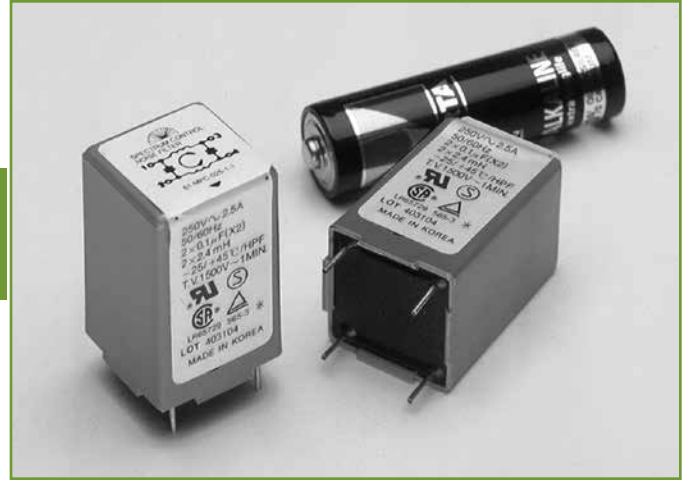

Circuit Diagram

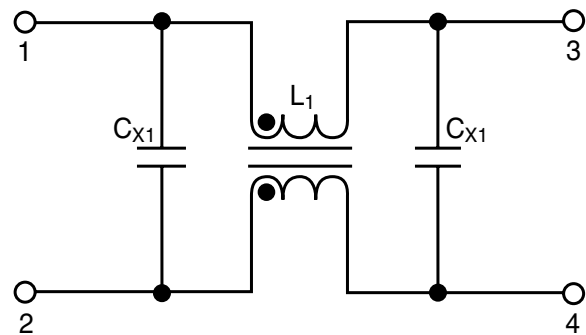

Specifications

Model	Rated Voltage (@ 50/60Hz)	Rated Current	Leakage Current (Max.)	Capacitance		Inductance (L ₁)	Temperature Rise (Max.)
				C _{X1}	C _{X2}		
61-MPC-010-1-11	250VAC	1A	0.1mA	0.1uF	0.1uF	11mH	40°C
61-MPC-016-1-11		1.6A				6.0mH	
61-MPC-025-1-11		2.5A				2.4mH	
61-MPC-036-1-11		3.6A				1.2mH	

Note: Test voltage: 1500VAC one minute, line to ground
Insulation resistance: 300 Mohm min. at 500VDC
Voltage drop: 1V max. at rated current
Weight: 17.5g

PCB Power Filters Miniature Printed Circuit Board

61-MPC Series

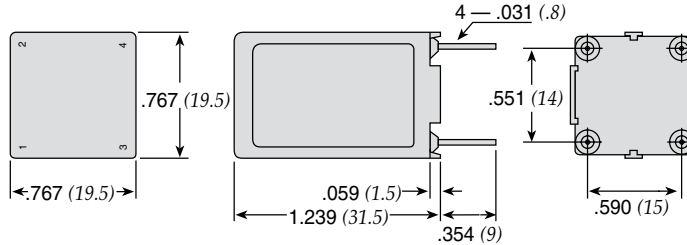

Dimensions in inches (mm)

Common Mode

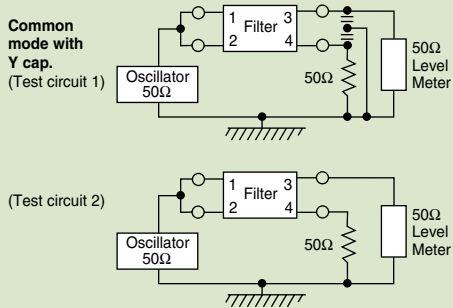

Temperature Characteristics

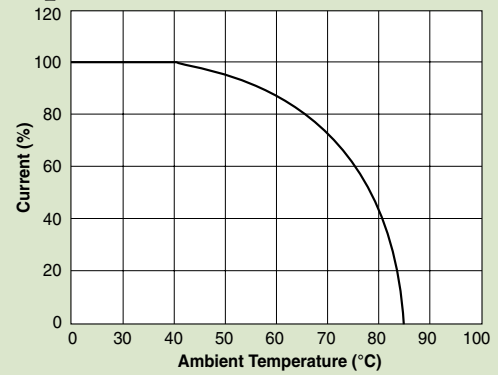

61-MPC

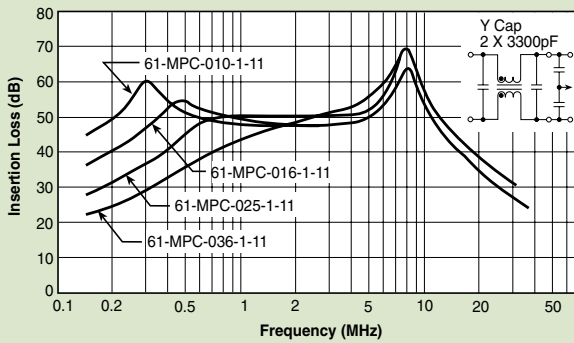

61-MPC

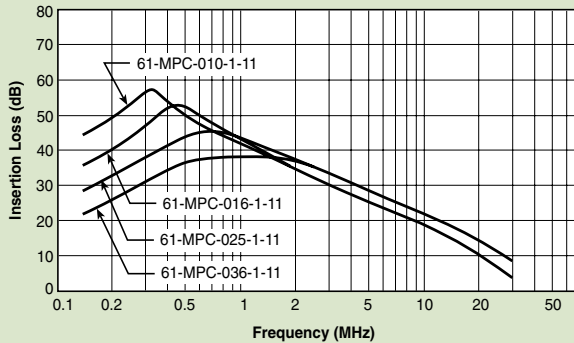

Normal Mode

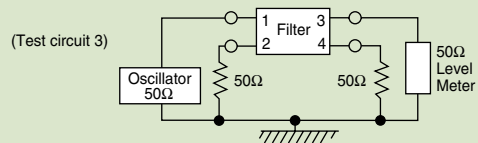

61-MPC

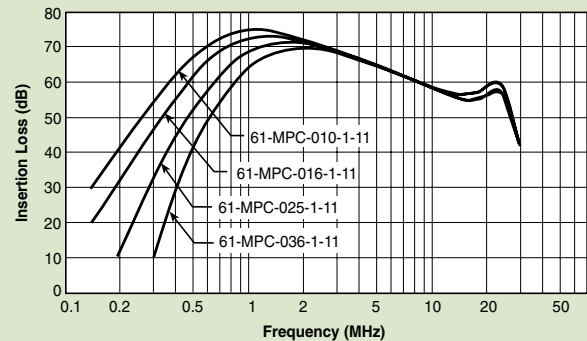

Power Entry Modules Bolt-in Right Angle Terminals

for PCB Applications

60-BPP Series



Tested and found to be
IAW VDE 0565 Part 3

Features

- Ideally suited for products that must conform to FCC part 15 regulations
- Metal case offers high performance
- Meets over voltage of IEC 664 category II and complies with IEC 950
- Uses IEC connector that meets most safety standards Solder lug, Fast-on tab styles available (see page PF18)
- PCB mounting style minimizes space and provides economical installation
- Operating temperature: -25°C to +85°C (including temperature rise, see graph on page PF47)
- UL approved low leakage version also available

Applications

- Digital equipment
- Personal computers and peripherals
- Measuring instruments
- Monitor and display units



Circuit Diagram

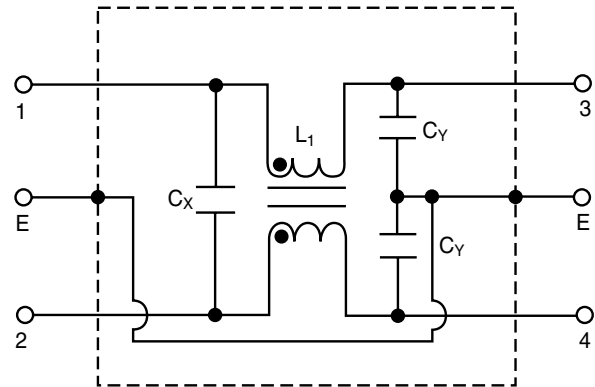

Specifications

Model	Rated Voltage (@ 50/60Hz)	Rated Current	Leakage Current (Max.)	Capacitance		Inductance (L ₁)	Temperature Rise (Max.)	
				C _Y	C _X			
60-BPP-010-3-2	250VAC	1A	0.35mA	2200pF	0.022uF	6.0mH	30°C	
60-BPP-010-3-4					0.047uF			
60-BPP-010-5-2			0.50mA	3300pF	0.022uF			
60-BPP-010-5-4					0.047uF			
60-BPP-020-3-2		2A	0.35mA	2200pF	0.022uF	2.4mH		
60-BPP-020-3-4					0.047uF			
60-BPP-020-5-2			0.50mA	3300pF	0.022uF			
60-BPP-020-5-4					0.047uF			
60-BPP-030-3-2		3A	0.35mA	2200pF	0.022uF	1.2mH		
60-BPP-030-3-4					0.047uF			
60-BPP-030-5-2			0.50mA	3300pF	0.022uF			
60-BPP-030-5-4					0.047uF			
60-BPP-060-3-2		6A	0.35mA	2200pF	0.022uF	0.53mH		45°C
60-BPP-060-3-4					0.047uF			
60-BPP-060-5-2			0.50mA	3300pF	0.022uF			
60-BPP-060-5-4					0.047uF			

Note: Test voltage: 1500VAC one minute, line to ground
 Insulation resistance: 300 Mohm min. at 500VDC
 Voltage drop: 1V max. at rated current
 Weight: 50g
 Input: Compatible with IEC-320

Power Entry Modules Bolt-in Right Angle Terminals for PCB Applications

60-BPP Series

Temperature Characteristics

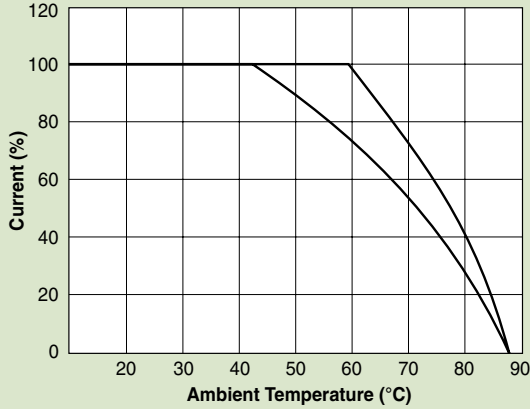

60-BPP PCB Mounting Type

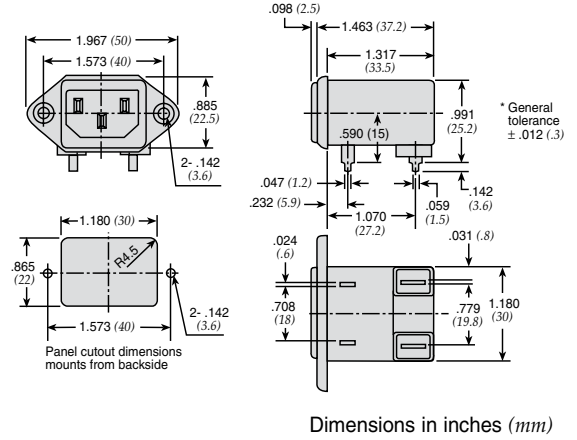

Common Mode

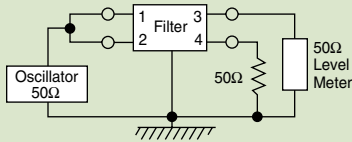

60-BPP-010;-020

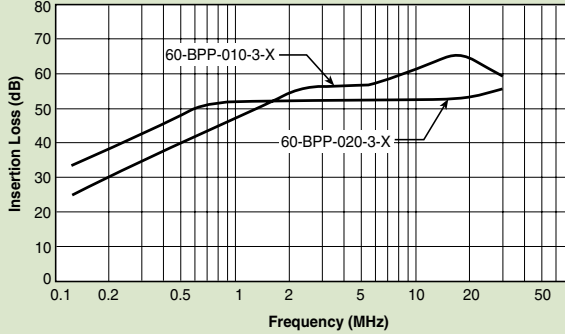

60-BPP-030;-060

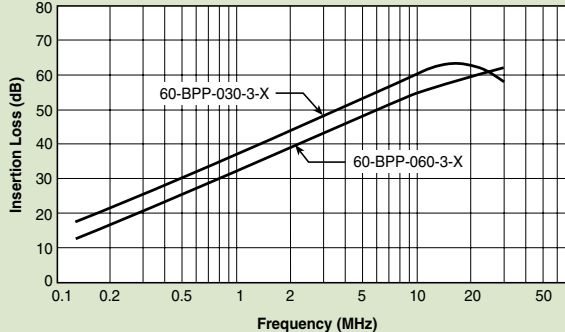

Normal Mode

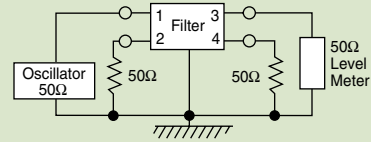

60-BPP-010;-020

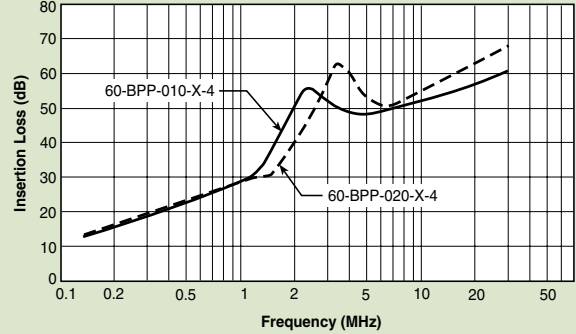

60-BPP-030;-060

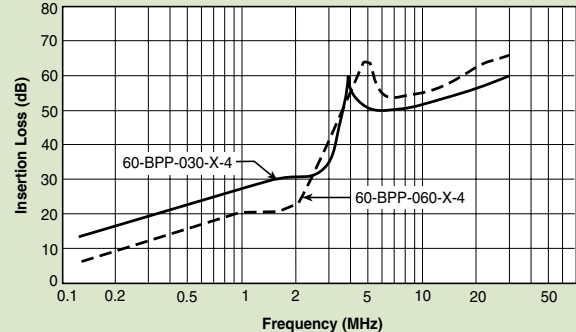

Power Entry Modules High Frequency Attenuation

Bolt-in for PCB Applications

60-BHP Series



Tested and found to be
IAW VDE 0565 Part 3

Features

- Ideally suited for products that must conform to FCC part 15 regulations
- Metal cased filter offers high performance
- Meets over voltage of IEC 664 category II and complies with IEC 950
- Solder lug, Fast-on tab styles available (see page PF20)
- PCB mounting minimizes space and provides economical installation
- Excellent filtering characteristics for high frequencies
- Earth coil standard
- Operating temperature: -25°C to +85°C (including temperature rise, see graph on page PF49)

Applications

- Digital equipment
- Personal computers and peripherals
- Measuring instruments
- Monitor and display units

Specifications

Model	Rated Voltage (@ 50/60Hz)	Rated Current	Leakage Current (Max.)	Capacitance		Inductance		Temperature Rise (Max.)
				C _Y	C _X	(L ₁)	(L ₂)	
60-BHP-010-3-11	250VAC	1A	0.35mA	2200pF±20%	0.1uF±20%	6mH	18.3 uH	30°C
60-BHP-010-3-4					.047uF±20%			
60-BHP-010-5-11			0.50mA	3300pF±20%	0.1uF±20%			
60-BHP-010-5-4					.047uF±20%			
60-BHP-020-3-11		2A	0.35mA	2200pF±20%	0.1uF±20%	2.4mH		
60-BHP-020-3-4					.047uF±20%			
60-BHP-020-5-11			0.50mA	3300pF±20%	0.1uF±20%			
60-BHP-020-5-4					.047uF±20%			
60-BHP-030-3-11		3A	0.35mA	2200pF±20%	0.1uF±20%	1.2mH		
60-BHP-030-3-4					.047uF±20%			
60-BHP-030-5-11			0.50mA	3300pF±20%	0.1uF±20%			
60-BHP-030-5-4					.047uF±20%			
60-BHP-060-3-11		6A	0.35mA	2200pF±20%	0.1uF±20%	0.53mH		45°C
60-BHP-060-3-4					.047uF±20%			
60-BHP-060-5-11			0.50mA	3300pF±20%	0.1uF±20%			
60-BHP-060-5-4					.047uF±20%			

Note: Test voltage: 1500VAC one minute, line to ground
Insulation resistance: 300 Mohm min. at 500VDC
Voltage drop: 1V max. at rated current
Weight: 50g
Input: Compatible with IEC-320



Circuit Diagram

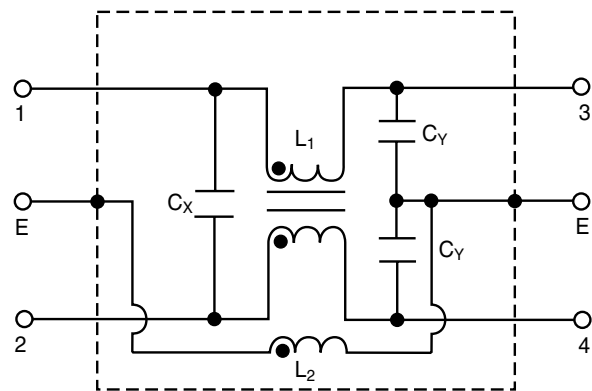

Power Entry Modules High Frequency Attenuation

Bolt-in for PCB Applications

60-BHP Series

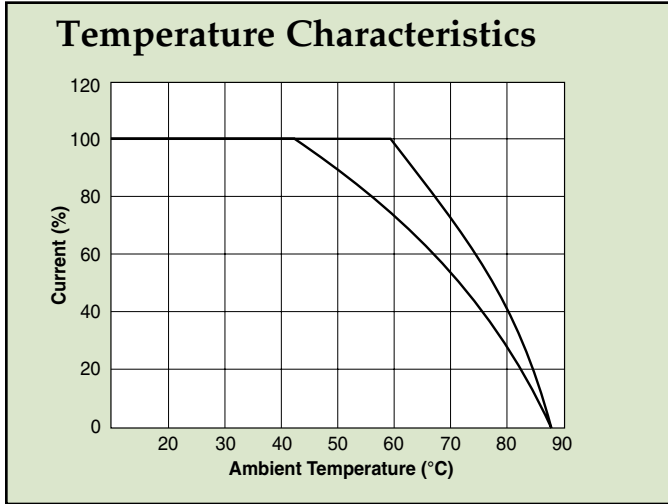

60-BHP PCB Mounting Type

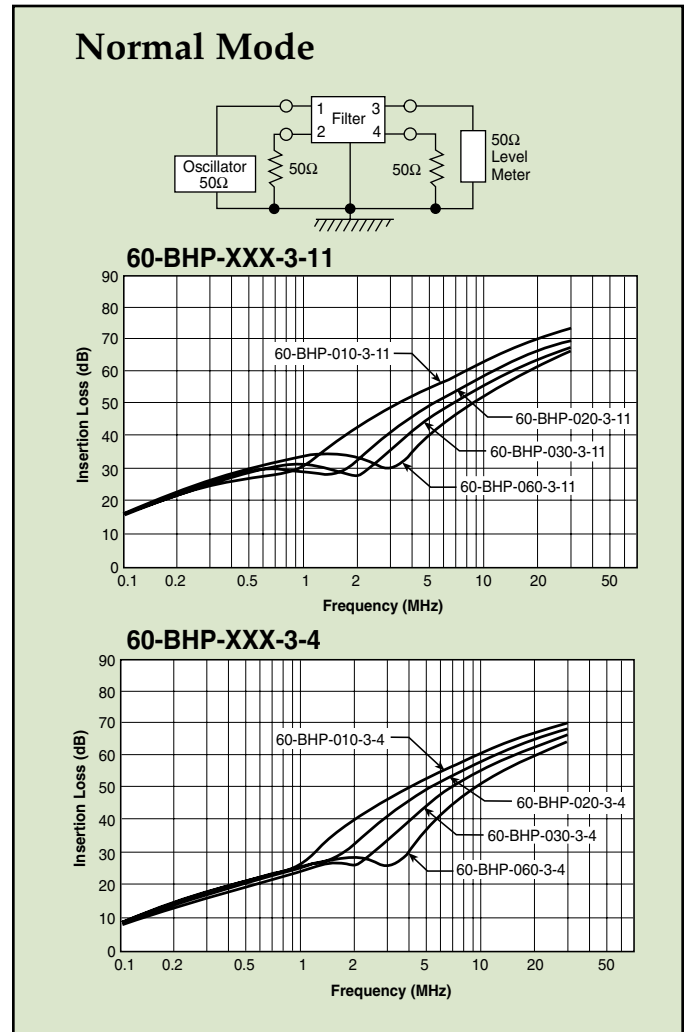
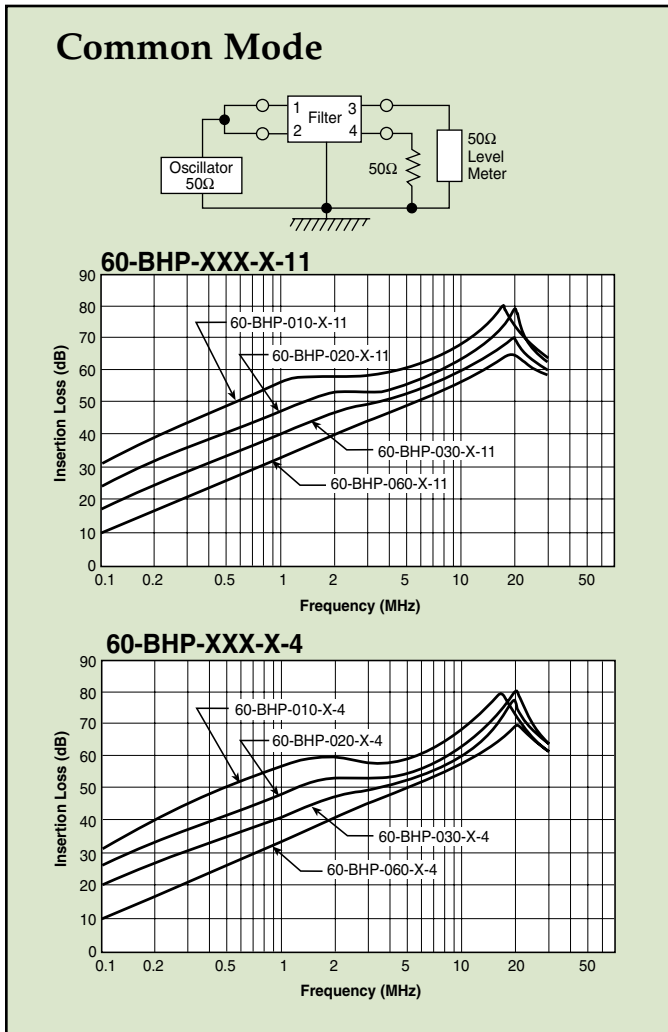
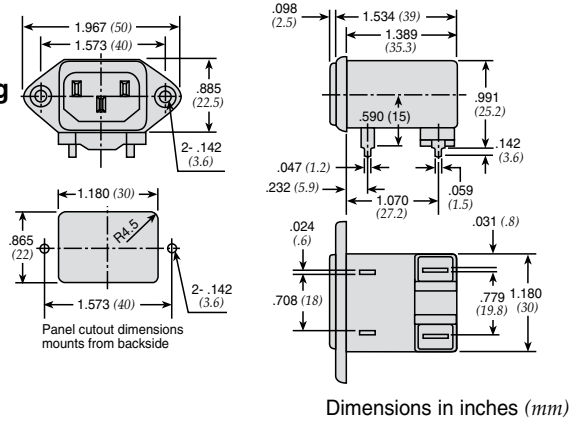

Power Line Filters Appliance Filters



11-MPC Series

Features

- Miniature general purpose PCB mounted filter
- Requires minimal PCB real estate space
- Low cost
- Operating temperature: -25°C to +70°C
- Two forms of cases are available: metal case and plastic case

Applications

- Personal computers and peripherals
- Digital equipment
- Measuring instruments and medical equipment
- TV & VCR monitors and display units
- Home appliances

Circuit Diagram

Circuit 1

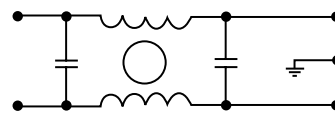

Circuit 2

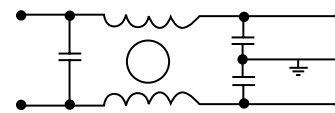

Circuit 3

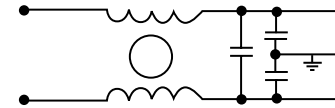

Circuit 4

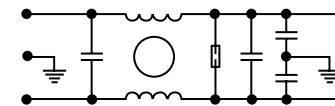

Specifications

Model	Rated Voltage (@ 50/60Hz)	Rated Current	Leakage Current (Max.)	Circuit Diagram	Figure	Temperature Rise (Max.)
11-MPC-001-2-B	120/250VAC	1A	0.50mA	1	A1	30°C
11-MPC-001-5-A				A		
11-MPC-001-5-B				A1		
11-MPC-002-5-B		2A		3	D	
11-MPC-002-5-D		3A		E		
11-MPC-003-5-E		6A		2	A1	
11-MPC-006-5-B				C		
11-MPC-006-5-C				4	B	
11-MPC-016-5-B		16A		0.2mA		

Note: Test voltage: 1500VAC one minute, line to ground
 Insulation resistance: 300 Mohm min. at 500VDC
 Voltage drop: 1V max. at rated current
 Weight: 17.5g

PCB Power Filters Miniature Printed Circuit Board

11-MPC Series

Figure A

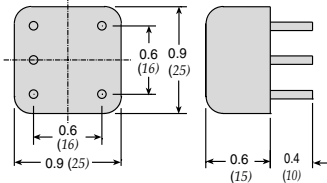

Figure A1

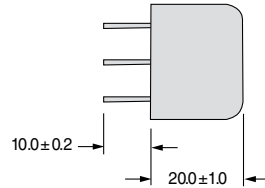

Figure B

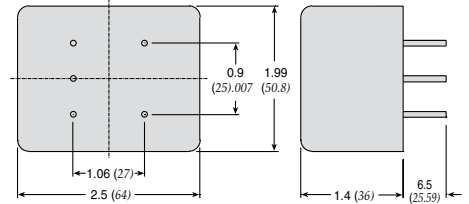

Figure C

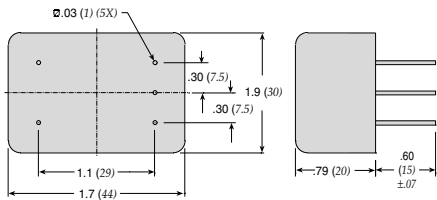

Figure D

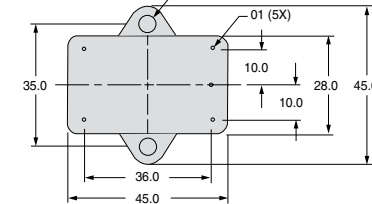
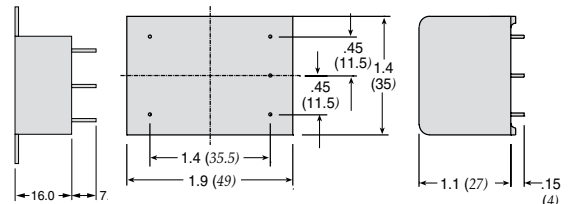
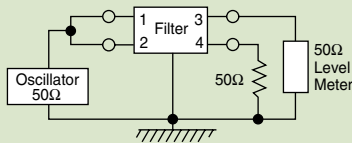

Figure E



Dimensions in inches (mm)

Common Mode



11-MPC-001;-002

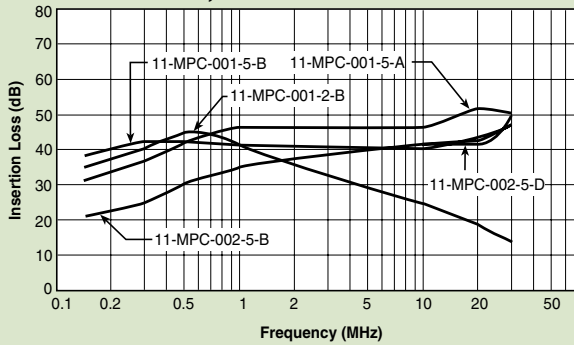

11-MPC-003;-006;-016

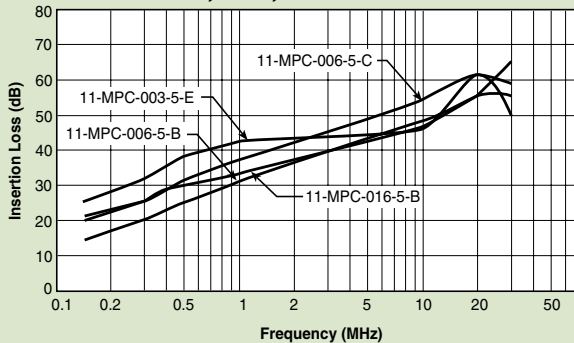

Normal Mode

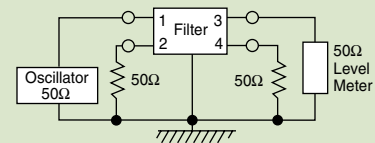

11-MPC-001;-002

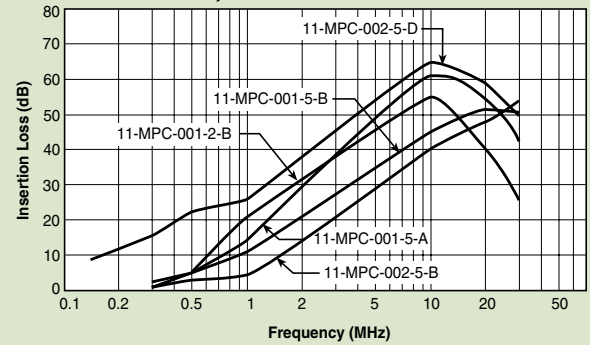

11-MPC-003;-006;-016

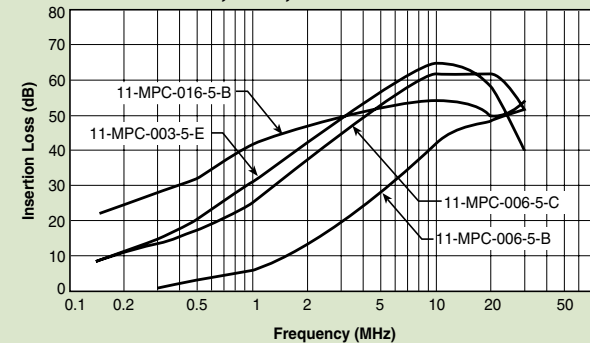

Power Line Filters Appliance Filters

62-AL/62-AC Series

Features

- Low-cost plastic case
- Compact design requires minimal real estate space
- Suitable for products that must conform to FCC regulations
- Wide variety of circuit and filtering options
- Good filtering characteristics for both normal mode and common mode
- Epoxy molded for reliability
- Operating temperature: -25°C to +85°C (including temperature rise, see graph on page PF53)



Tested and found to be IAW VDE 0565 Part 3

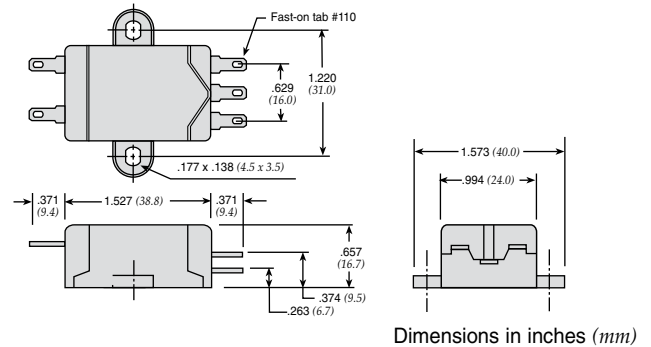

Applications

- Personal computers and peripherals
- Digital equipment
- Industrial equipment
- Vending machines
- Home appliances
- Office equipment

Circuit Diagrams

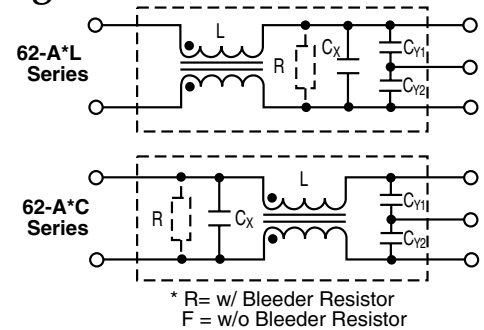

Specifications

Model*	Rated Voltage (@ 50/60Hz)	Rated Current	Leakage Current (Max.)	Capacitance		Inductance (L ₁)	Temperature Rise (Max.)
				C _Y	C _X		
62-AFL-010-3-11	250VAC	1.0A	0.35mA	2200pF	0.1uF	11.0mH	40°C
62-AFC-010-3-11			0.50mA				
62-AFL-010-5-11		1.6A	0.35mA				
62-AFC-010-5-11			0.50mA				
62-AFL-016-3-11		3.0A	0.35mA				
62-AFC-016-3-11			0.50mA				
62-AFL-016-5-11		4.5A	0.35mA				
62-AFC-016-5-11			0.50mA				
62-AFL-030-3-11		6.0A	0.35mA				
62-AFC-030-3-11			0.50mA				
62-AFL-030-5-11		4.5A	0.35mA				
62-AFC-030-5-11			0.50mA				
62-AFL-045-3-11		6.0A	0.35mA				
62-AFC-045-3-11			0.50mA				
62-AFL-045-5-11		6.0A	0.35mA				
62-AFC-045-5-11			0.50mA				
62-AFL-060-3-11		6.0A	0.35mA				
62-AFC-060-3-11			0.50mA				
62-AFL-060-5-11		6.0A	0.35mA				
62-AFC-060-5-11			0.50mA				

Note: All types are designed to meet the requirement of UL 1283, CSA 22.2. VDE 0565-3
 Test voltage: 1500VAC one minute, line to ground
 Insulation resistance: 300 Mohm min. at 500VDC
 Voltage drop: 1V max.

* Available with bleeder resistor
 Replace F with R for part number

Power Line Filters Appliance Filters

62-AL/62-AC Series

Common Mode

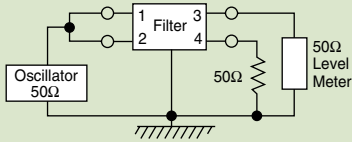

62-AFL-xxx-3-11

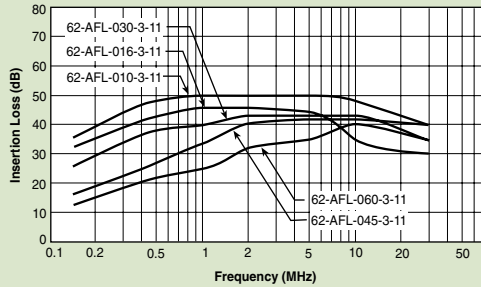

62-AFC-xxx-3-11

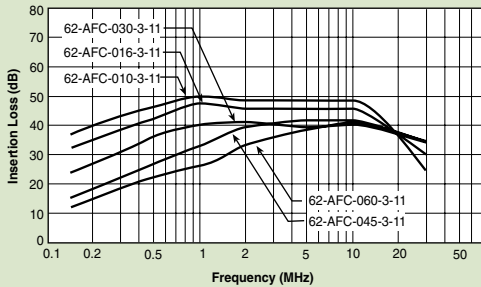

62-AFL-xxx-5-11

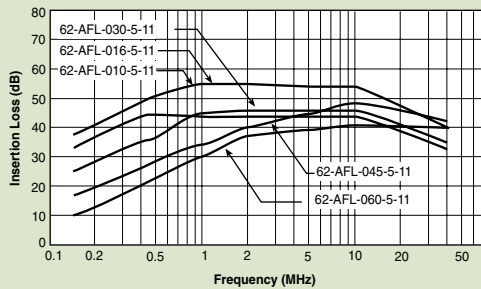

62-AFC-xxx-5-11

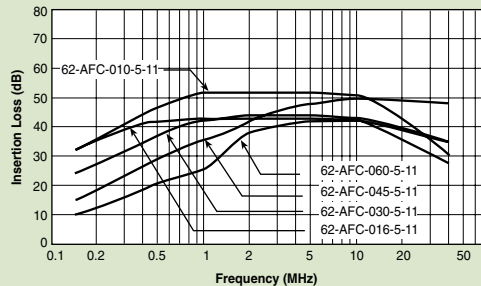

Temperature Characteristics

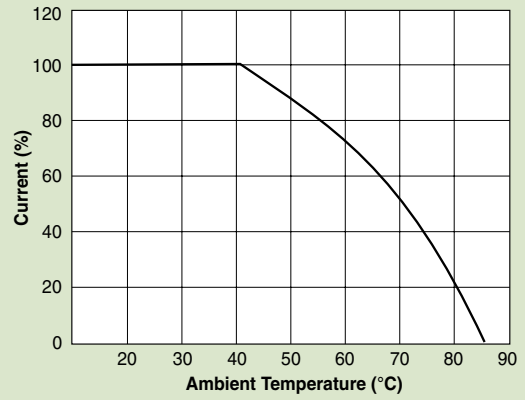

Normal Mode

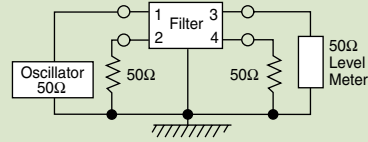

62-AFL-XXX-3-11

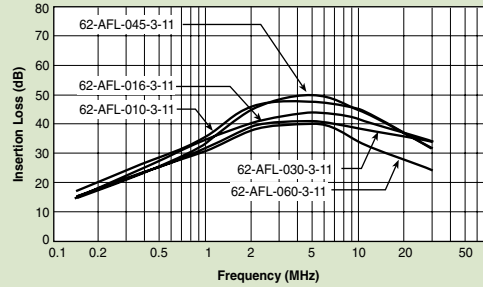

62-AFC-xxx-3-11

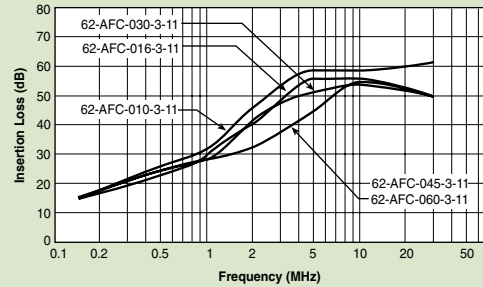

62-AFL-xxx-5-11

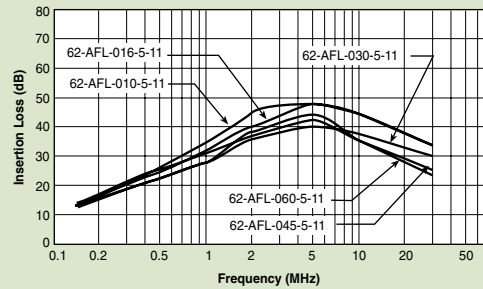

62-AFC-xxx-5-11

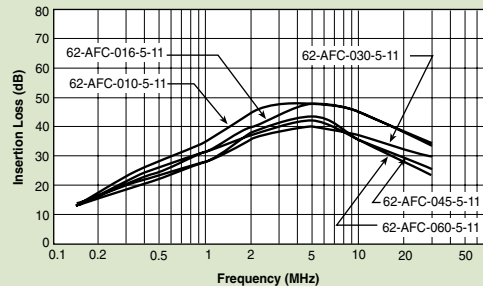

Power Line Filters Single Stage

62-PPF/PQF/PRF Series



Tested and found to be
IAW VDE 0565 Part 3

Features

- Low-cost plastic case
- Compact design requires minimal real estate space
- Suitable for products that must conform to FCC and FTZ regulations
- Wide variety of circuit and filtering options
- Good filtering characteristics for both normal mode and common mode
- Epoxy molded for reliability
- Operating temperature: -25°C to +85°C (including temperature rise, see graph on page PF55)

Applications

- Personal computers and peripherals
- Digital equipment
- Industrial equipment
- Vending machines
- Office equipment



Circuit Diagrams

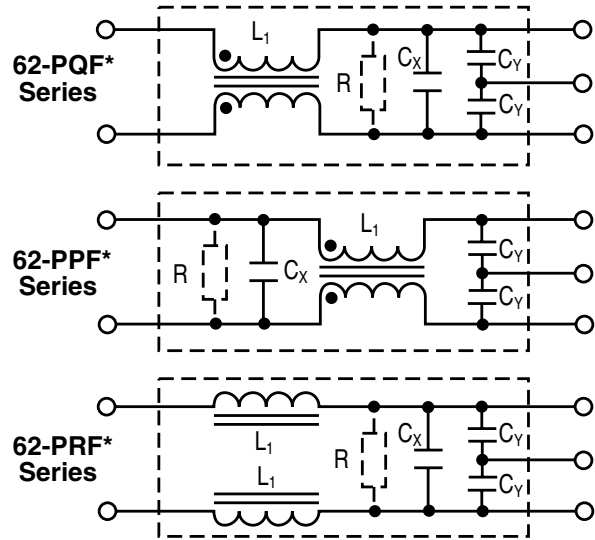

* Bleeder Resistor is available only for
62-P(Q/R/P)F-XXX-X-12

Specifications

Model	Rated Voltage (@ 50/60Hz)	Rated Current	Leakage Current (Max.)	Capacitance		Inductance (L ₁)	Temperature Rise (Max.)	
				C _Y	C _X			
62-PQF-020-5-11	250VAC	2A	0.50mA	3300pF	0.1uF	15mH	30°C	
62-PQF-020-5-12					.22uF			
62-PPF-020-5-11					0.1uF			
62-PPF-020-5-12					.22uF			
62-PQF-030-5-11					0.1uF			8mH
62-PQF-030-5-12					.22uF			
62-PPF-030-5-11		0.1uF						
62-PPF-030-5-12		.22uF						
62-PQF-060-5-11		0.1uF			2.1mH			
62-PQF-060-5-12		.22uF						
62-PPF-060-5-11		0.1uF						
62-PPF-060-5-12		.22uF						
62-PRF-010-5-11		0.1uF			486uH			
62-PRF-010-5-12		.22uF						
62-PRF-020-5-11		0.1uF			181uH			
62-PRF-020-5-12		.22uF						
62-PRF-030-5-11		0.1uF			97uH			
62-PRF-030-5-12		.22uF						

Note: All types are designed to meet the requirement of UL 1283, CSA 22.2. VDE 0565-3

Test voltage: 1500VAC one minute, line to ground

Insulation resistance: 300 Mohm min. at 500VDC

Voltage drop: 1V max. (except 62-PRF-010-5-11) at rated current

62-PRF-010-5-11: 1.5V max. at rated current

Weight: 62-PPF & PQF Series: 2.11 ounces (60 grams)

62-PRF Series: 1.76 ounces (50 grams)

Power Line Filters Single Stage

62-PPF/PQF/PRF Series

Temperature Characteristics

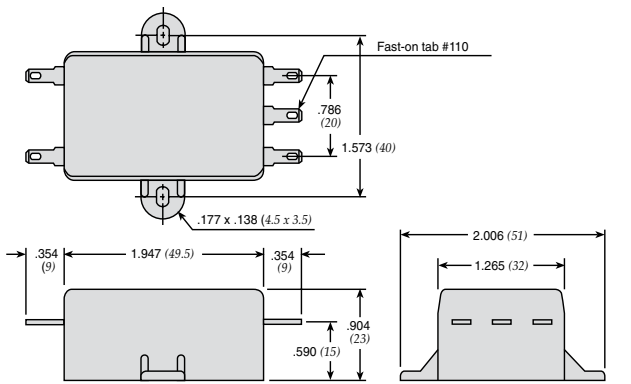
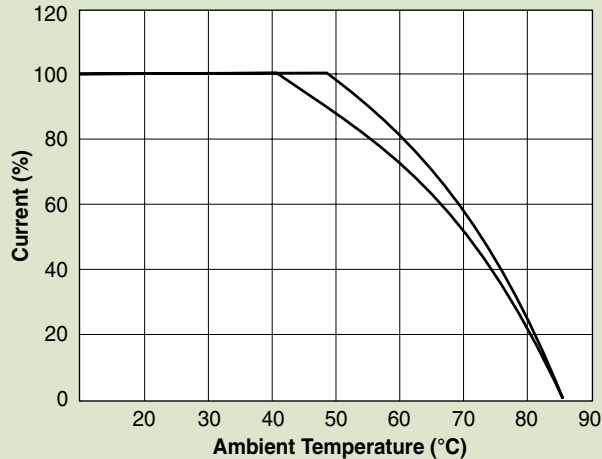

Also available with .250 Fast-ons

Dimensions in inches (mm)

Normal Mode

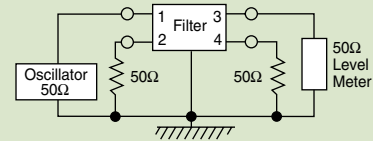

62-PQF Series

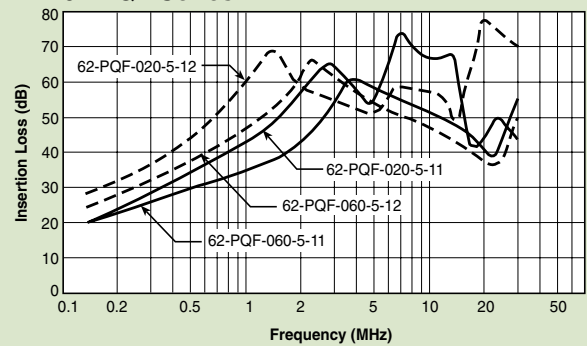

62-PPF Series

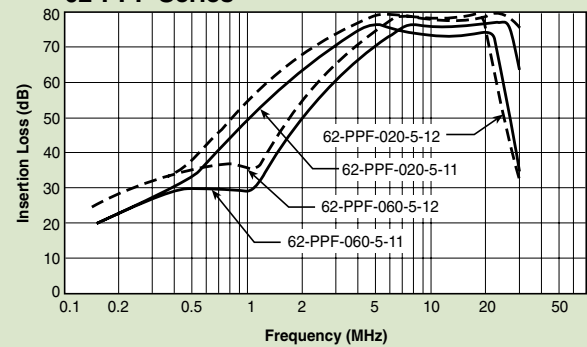

Common Mode

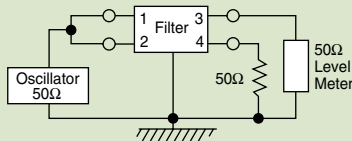

62-P(P/Q/R)F Series

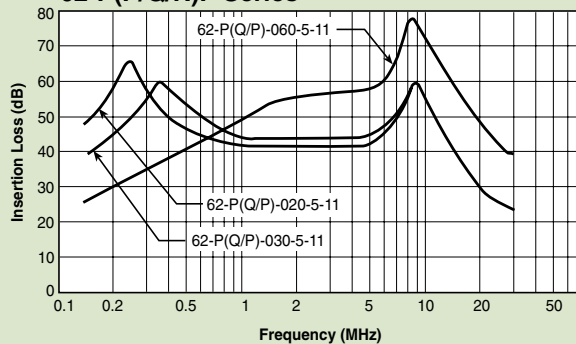

62-PRF Series

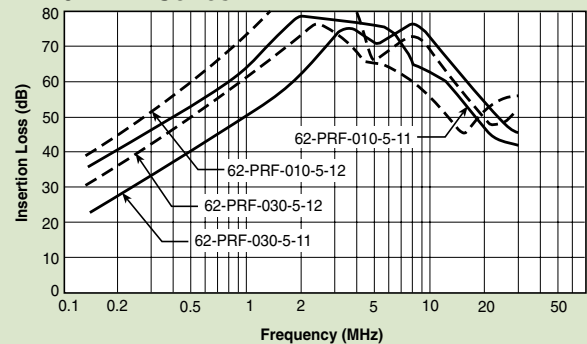

Power Line Filters Single Stage Wire Leads

62-PML Series

Features

- Compact design requires minimal real estate space
- Suitable for products that must conform to FCC and FTZ regulations
- Excellent attenuation for high voltage impulse
- Metal case provides effective shielding
- Excellent filtering characteristics for both normal mode and common mode
- Structure provides effective shielding for noise generated externally and internally
- Operating temperature: -25°C to +85°C (including temperature rise, see graph on page PF57)

Applications

- Digital equipment
- Personal computers and peripherals
- Measuring instruments
- Medical equipment
- Factory automation equipment



Tested and found to be
IAW VDE 0565 Part 3



Circuit Diagram

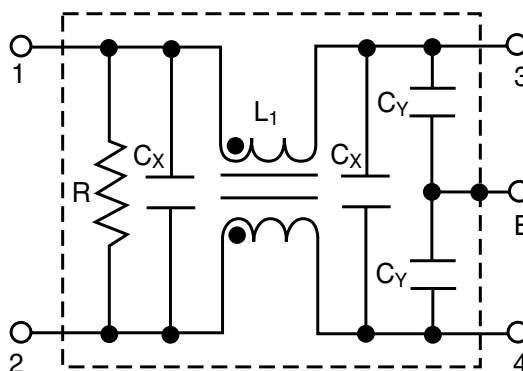

Specifications

Model	Rated Voltage (@ 50/60Hz)	Rated Current	Leakage Current (Max.)	Capacitance		Inductance (L ₁)	Temperature Rise (Max.)
				C _Y	C _X		
62-PML-015-3-11	250VAC	1.5A	0.35mA	0.1uF	3300pF	10.0mH	30°C
62-PML-015-5-11			0.50mA				
62-PML-030-3-11		3A	0.35mA			4.3mH	
62-PML-030-5-11			0.50mA				
62-PML-050-3-11		5A	0.35mA			2.4mH	
62-PML-050-5-11			0.50mA				

Note: All types are designed to meet the requirement of UL 1283, CSA 22.2. VDE 0565-3
 Test voltage: 1500VAC one minute, line to ground
 Insulation resistance: 300 Mohm min. at 500VDC
 Voltage drop: 1V max. at rated current
 Weight: 62-PML-015 Series: 3.06 ounces (87 grams)
 62-PML-030 Series: 3.17 ounces (90 grams)
 62-PML-050 Series: 3.28 ounces (93 grams)
 Discharge time: 0.4 sec. max.

Power Line Filters Single Stage Wire Leads

62-PML Series

Temperature Characteristics

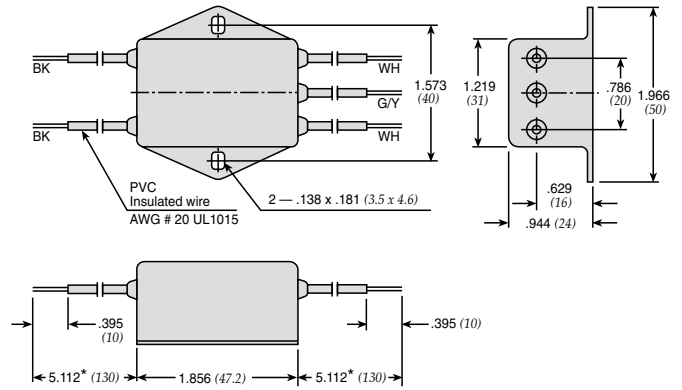
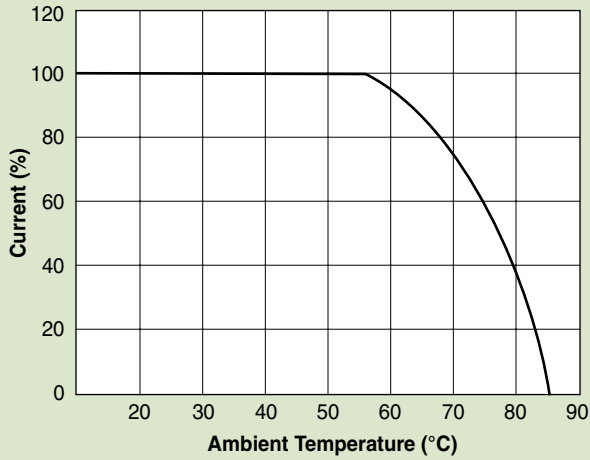

* Custom lengths available upon request. Dimensions in inches (mm)

Common Mode

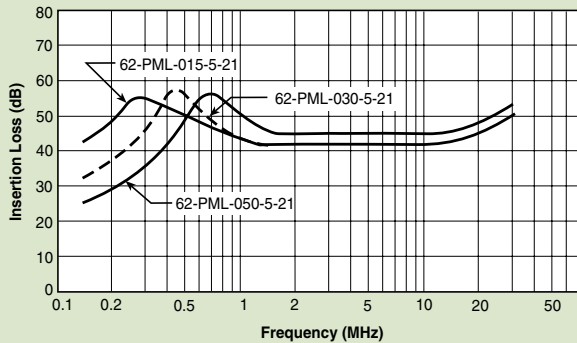
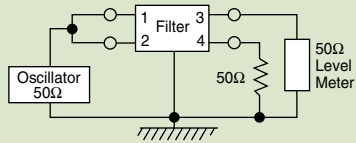

Normal Mode

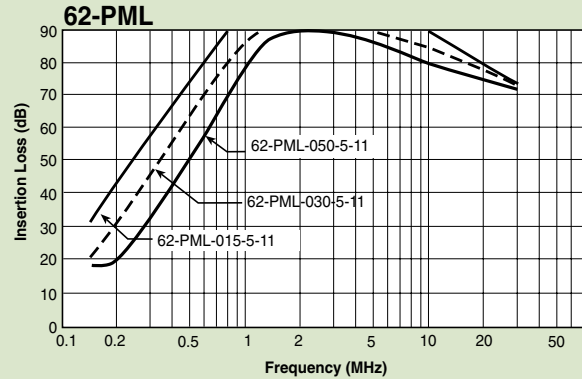
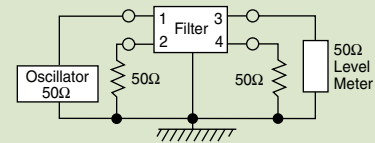

Power Line Filters Single Stage Wire Leads

for Medical Purpose Applications

12-PML & 12-PMF Series



Features

- Compact design requires minimal real estate space
- Suitable for products that must conform to FCC and FTZ regulations
- Excellent attenuation for high voltage impulse
- Metal case provides effective shielding
- Excellent filtering characteristics for both normal mode and common mode
- Structure provides effective shielding for noise generated externally and internally
- Operating temperature: -25°C to +70°C
- Low leakage current

Applications

- Digital equipment
- Personal computers and peripherals
- Measuring instruments
- Medical equipment
- Factory automation equipment



Circuit Diagram

Circuit 1

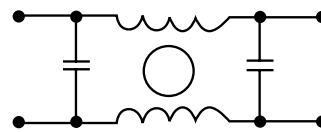

Circuit 2

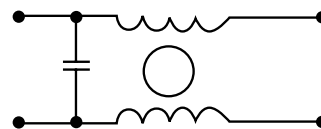

Specifications

Model	Rated Voltage (@ 50/60Hz)	Rated Current	Leakage Current (Max.)	Circuit Diagram	Figure	Temperature Rise (Max.)
12-PML-001-2-A	120/250VAC	1A	5uA	1	A	30°C
12-PML-002-2-A		2A				
12-PML-006-2-A		6A				
12-PML-010-2-A		10A				
12-PMF-001-2-B		1A		2	B	
12-PMF-002-2-B		2A				
12-PMF-006-2-B		6A				
12-PML-001-2-C				1A		

Note: All types are designed to meet the requirement of UL 1283, CSA 22.2. VDE 0565-3
 Test voltage: 1500VAC one minute, line to ground
 Insulation resistance: 300 Mohm min. at 500VDC
 Voltage drop: 1V max. at rated current
 Discharge time: 0.4 sec. max.

Power Line Filters Single Stage Wire Leads

for Medical Purpose Applications

12-PML & 12-PMF Series

Figure A

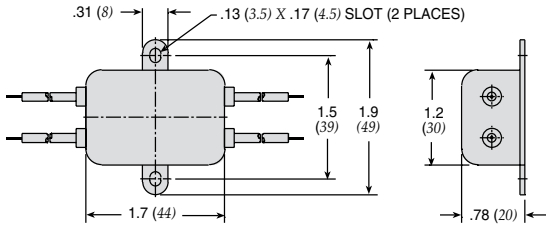

Figure C

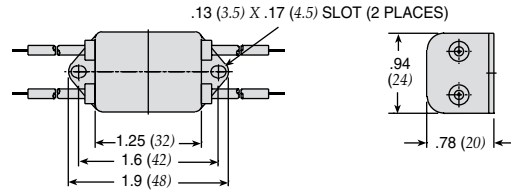
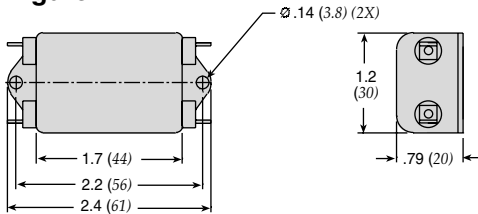
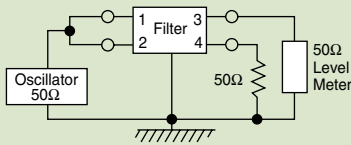

Figure B



Dimensions in inches (mm)

Common Mode



12-PML-001;-002;-006;-010

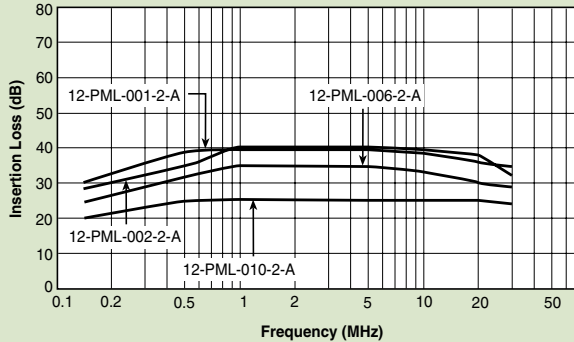

12-PMF-001;-002;-006;-010

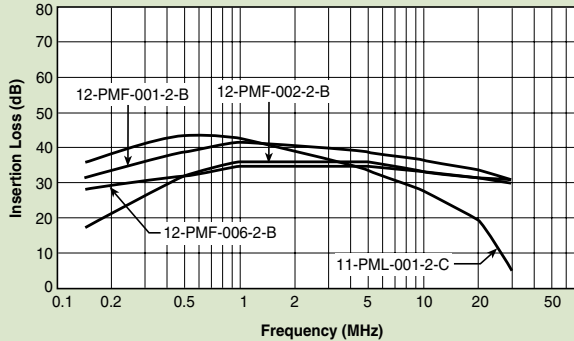

Normal Mode

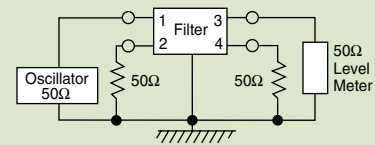

12-PML-001;-002;-006;-010

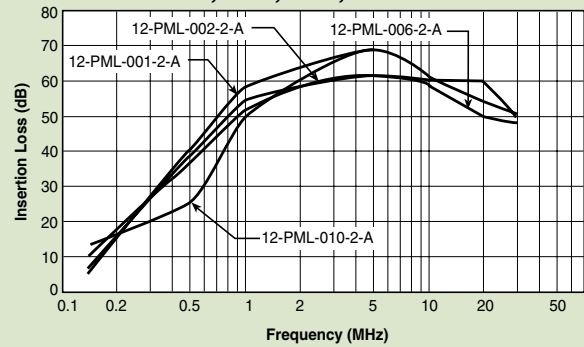

12-PMF-001;-002;-006;-010

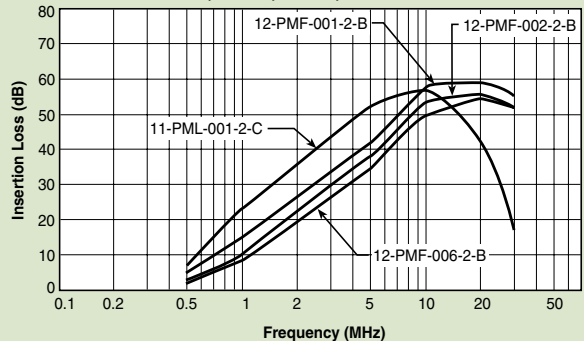

Power Line Filters Single Stage

62-LMF & LMB Series

Features

- Space saving, compact designs
- Suitable for products that must conform to FCC and FTZ regulations
- Excellent filtering characteristics for both normal mode and common mode
- Structure provides effective shielding for noise generated externally and internally
- Metal case provides effective shielding
- Rugged construction
- Operating temperature: -25°C to +85°C (including temperature rise, see graph on page PF61)

Applications

- Digital equipment
- Office automation equipment, such as copy and fax machines
- Computers and peripherals
- Instrumentation and controls



Tested and found to be IAW VDE 0565 Part 3



Circuit Diagram

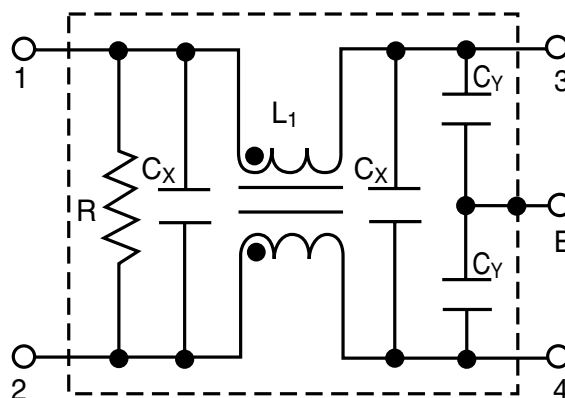

Specifications

Model*	Rated Voltage (@ 50/60Hz)	Rated Current	Leakage Current (Max.)	Capacitance		Inductance (L ₁)	Temperature Rise (Max.)
				C _Y	C _X		
62-LMB-030-5-11	250VAC	3A	0.50mA	3300pF	0.1uF	14mH	45°C
62-LMF-030-5-11		5A			0.1uF & .22uF	7.0mH	
62-LMB-050-5-11					8A	.22uF	
62-LMF-050-5-11		10A				.33uF	
62-LMB-080-5-11					.33uF	2.2mH	
62-LMF-080-5-11							
62-LMB-100-5-11							
62-LMF-100-5-11							

Note: Test voltage: 1500VAC one minute, line to ground
 Insulation resistance: 300 Mohm min. at 500VDC
 Voltage drop: 1V max. at rated current
 Discharge time: 0.4 sec. max.
 Weight: 5.3 ounces (150 grams)

*62-LMF - designates Fast-on terminals
 62-LMB - designates Bolt-in terminals
 62-LML - wire lead in/outputs also available

Power Line Filters Single Stage

62-LMF & LMB Series

Temperature Characteristics

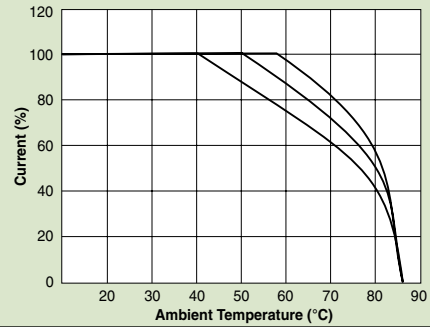

62-LMB

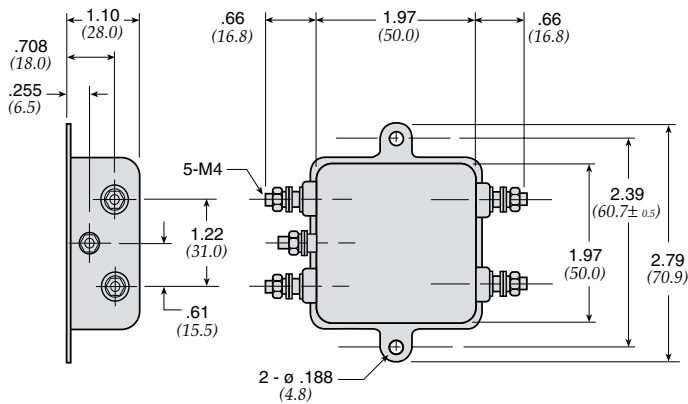

62-LMF

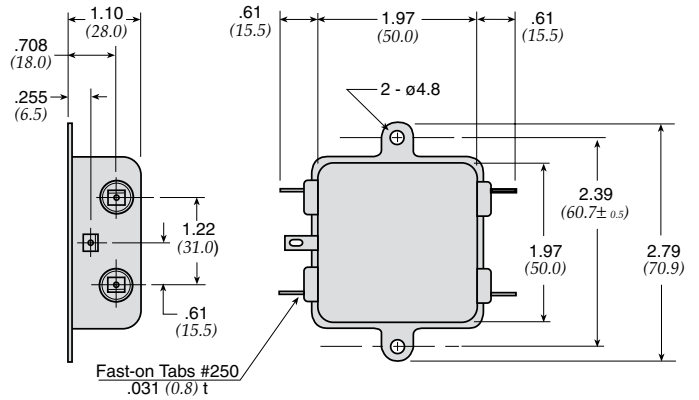

Dimensions in inches (mm)

Common Mode

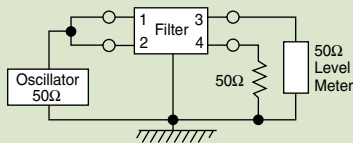

62-LMF & LMB

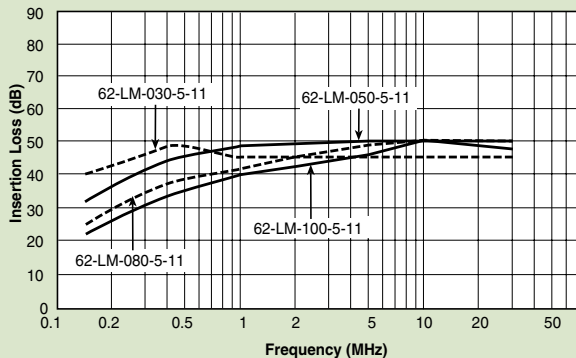

Normal Mode

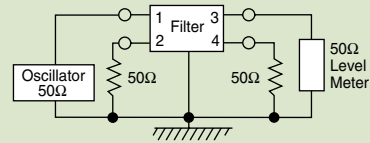

62-LMF & LMB

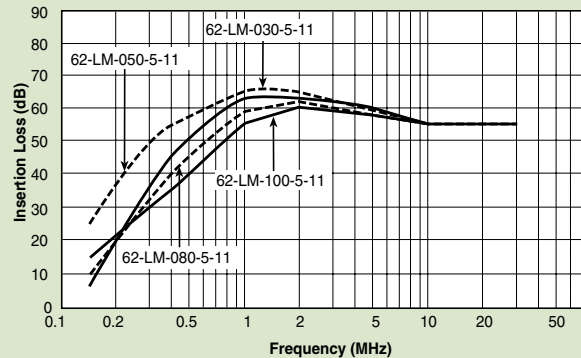

Power Line Filters Single Stage

62-PMF & PMB Series



Tested and found to be
IAW VDE 0565 Part 3

Features

- Space-saving, compact designs
- Suitable for products that must conform to FCC regulations
- Excellent attenuation for high voltage impulse
- Metal case provides effective EMI shielding
- Excellent filtering characteristics for both normal mode and common mode
- Epoxy molded for internal component reliability
- Structure provides effective shielding for noise generated externally and internally
- Operating temperature: -25°C to +85°C (including temperature rise, see graph on page PF63)

Applications

- Digital equipment
- Computers and peripherals
- Measuring instruments
- Medical equipment
- Equipment requiring very high impulse attenuation
- Factory automation equipment
- Industrial equipment such as UPS, inverters and converters
- Telecommunications equipment
- Office automation equipment, such as copy and fax machines



Circuit Diagram

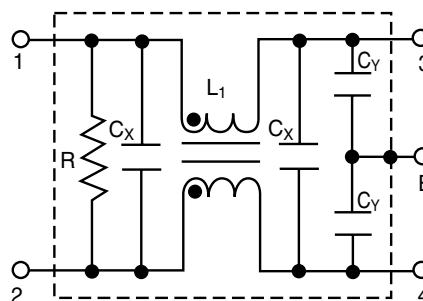

Specifications

Model*	Rated Voltage (@ 50/60Hz)	Rated Current	Leakage Current (Max.)	Capacitance		Inductance (L ₁)	Temperature Rise (Max.)	
				C _Y	C _X			
62-PMB-050-5-11	250VAC	5A	0.50mA	3300pF	0.1uF	14mH	30°C	
62-PMF-050-5-11								
62-PMB-080-5-11		8A						7.0mH
62-PMF-080-5-11								
62-PMB-100-5-12		10A				4.2mH		
62-PMF-100-5-12								
62-PMB-150-5-13		15A				2.2mH		35°C
62-PMF-150-5-13								
62-PMB-200-5-13		20A				1.8mH		45°C**
62-PMF-200-5-13								

Note: Test voltage: 1500VAC one minute, line to ground
Insulation resistance: 300 Mohm min. at 500VDC
Voltage drop: 1V max.
Discharge time: 0.4 sec. max.
Weight: 8.82 ounces (250 grams)

* PMF - designates Fast-on terminals

PMB - designates Bolt-in terminals

** The temperature rise of 20 amp units can be decreased to 30°C by mounting on 200 X 200 x 1.0(mm) steel chassis

Power Line Filters Single Stage

62-PMF & PMB Series

Temperature Characteristics

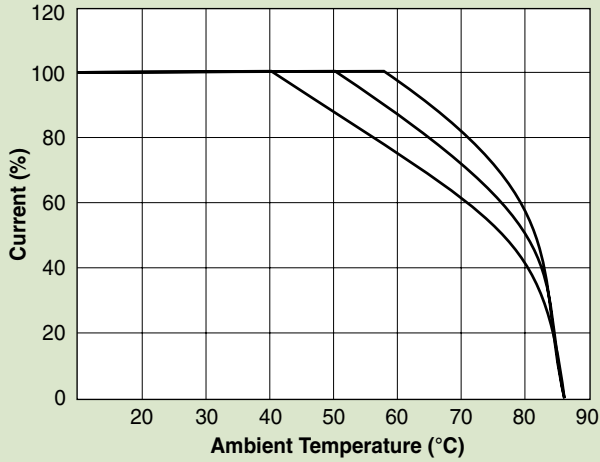

62-PMF

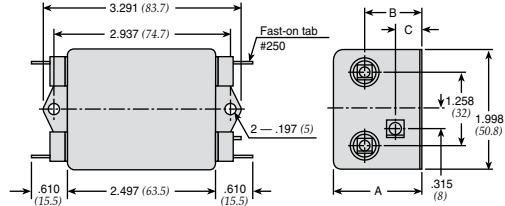

62-PMB

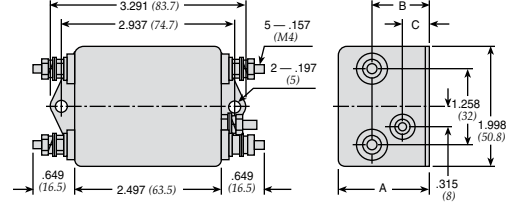

MODEL	A	B	C
62-PMF/PMB-100-200	1.490 (38)	.944 (24)	.433 (11)
62-PMF/PMB-050-080	1.258 (32)	.786 (20)	0 (0)

Dimensions in inches (mm)

Common Mode

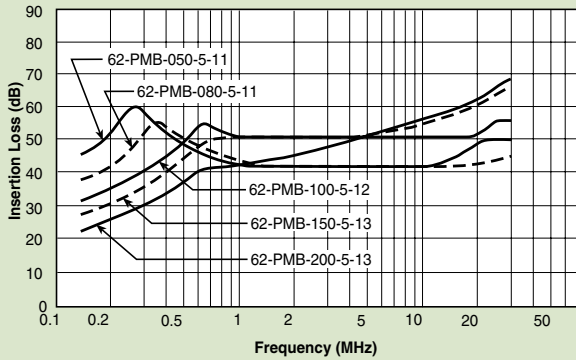
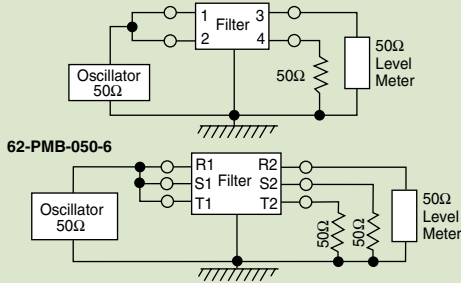

Normal Mode

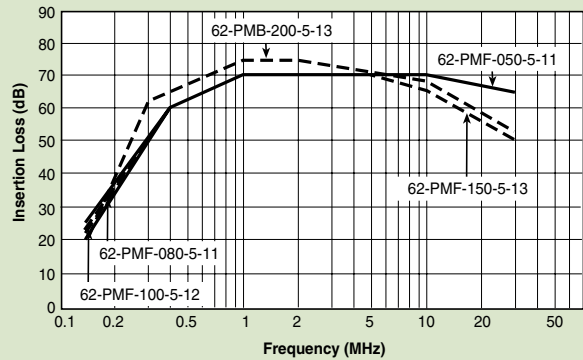
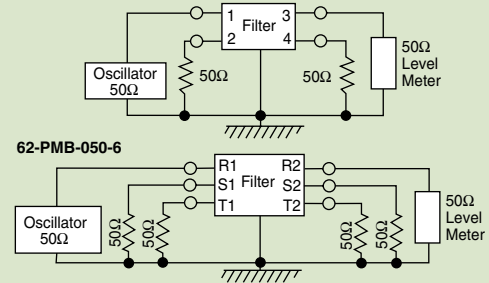

Power Line Filters Single Stage

12-PMF Series



Features

- Space-saving, compact designs
- Suitable for products that must conform to FCC regulations
- Excellent attenuation for high voltage impulse
- Metal case provides effective EMI shielding
- Excellent filtering characteristics for both normal mode and common mode
- Epoxy molded for internal component reliability
- Structure provides effective shielding for noise generated externally and internally
- Operating temperature: -25°C to +85°C

Applications

- Digital equipment
- Computers and peripherals
- Measuring instruments
- Medical equipment
- Equipment requiring very high impulse attenuation
- Factory automation equipment
- Industrial equipment such as UPS, inverters and converters
- Telecommunications equipment
- Office automation equipment, such as copy and fax machines



Circuit Diagram

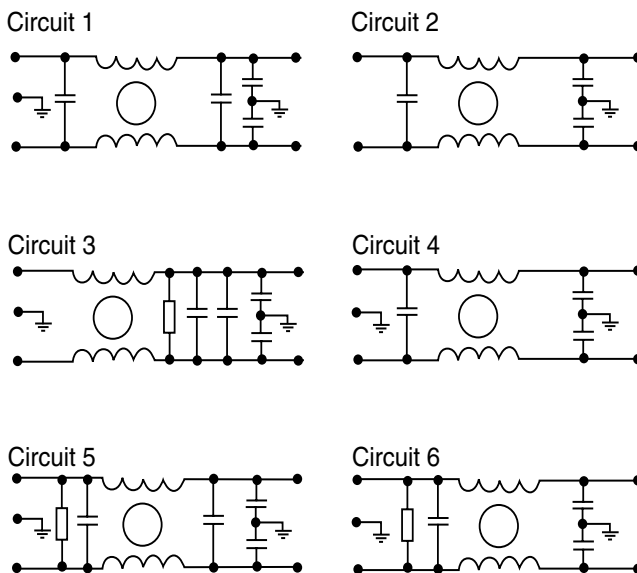

Specifications

Model	Rated Voltage (@ 50/60Hz)	Rated Current	Leakage Current (Max.)	Circuit Diagram	Figure	Temperature Rise (Max.)
12-PMF-001-5-A	120/250VAC	1A	0.5mA	1	A	30°C
12-PMF-002-5-B		2A		2	B	
12-PMF-003-5-A		3A		4	A	
12-PMF-003-5-B		2		B		
12-PMF-006-5-A		4		A		
12-PMF-006-5-C		1		C		
12-PMF-006-5-D		6		D		
12-PMF-010-5-A		10A		2	A	
12-PMF-010-5-C		3		C		
12-PMF-015-5-C		15A		5	E	
12-PMF-015-5-E		C				
12-PMF-020-5-C		D				
12-PMF-020-5-D		D				
12-PMF-020-5-E		E				

Note: Test voltage: 1500VAC one minute, line to ground
 Insulation resistance: 300 Mohm min. at 500VDC
 Voltage drop: 1V max.
 Discharge time: 0.4 sec. max.

Power Line Filters Single Stage

12-PMF Series

Figure A

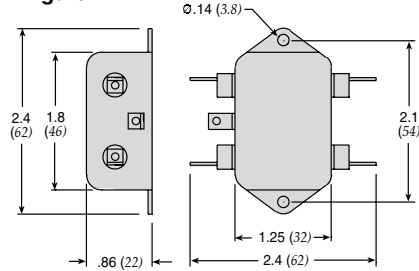

Figure B

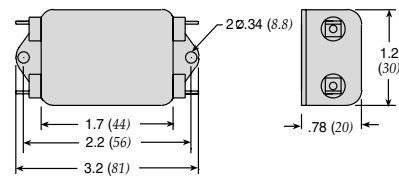

Figure C

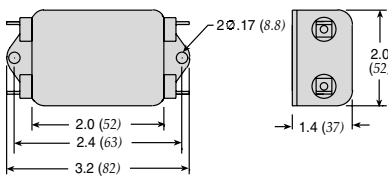

Figure D

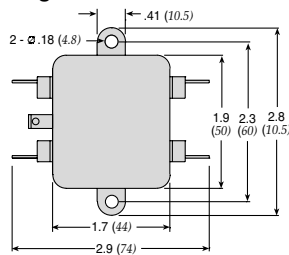
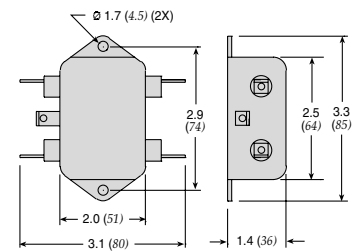
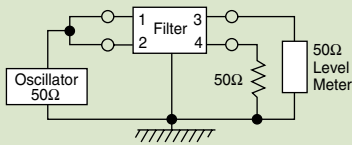

Figure E



Dimensions in inches (mm)

Common Mode



12-PMF-001;-002;-003;-006

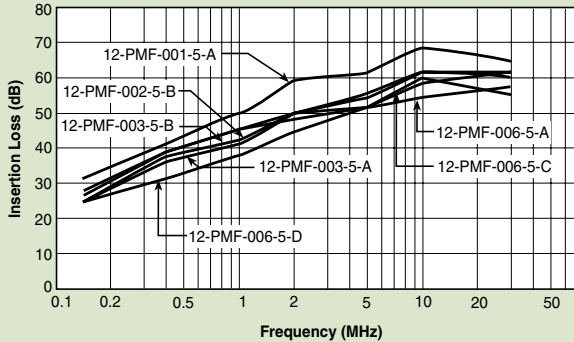

12-PMF-001;-002;-003;-006

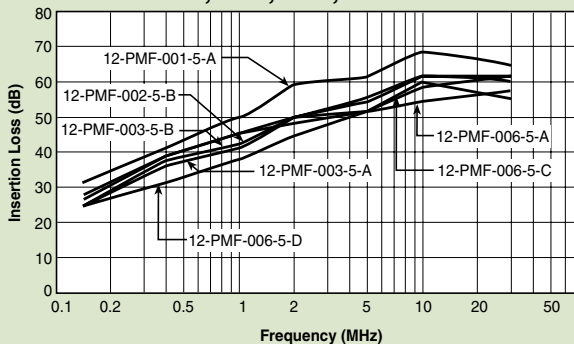

Normal Mode

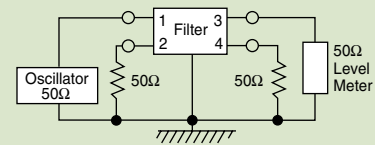

12-PMF-001;-002;-003;-006

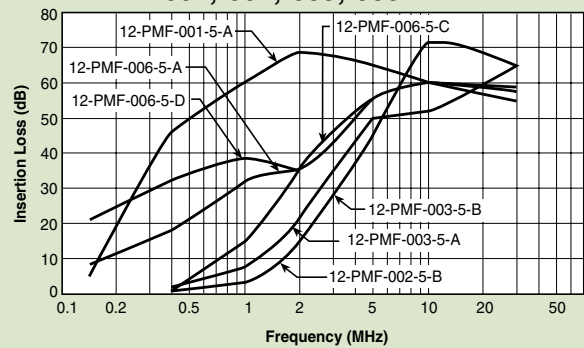

12-PMF-010;-015;-020

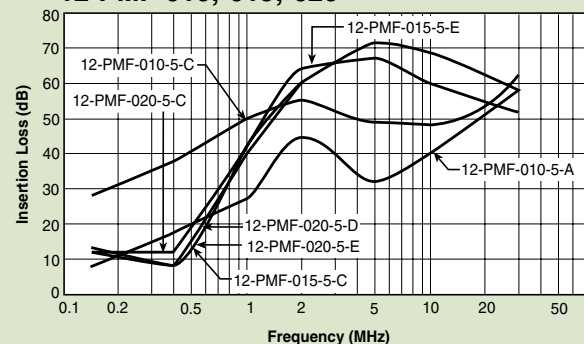

Power Line Filters Single Stage - Higher Current



62-PMB Series

Features

- Space-saving, compact designs
- Suitable for products that must conform to FCC regulations
- Excellent attenuation for high voltage impulse
- Metal case provides effective shielding
- Excellent filtering characteristics for both normal mode and common mode
- Epoxy molded for internal component reliability
- Structure provides effective shielding for noise generated externally and internally
- Safety agency approvals pending
- Designed to be in accordance with VDE 0565 Part 3
- Operating temperature: -25°C to +85°C (including temperature rise)

Applications

- Digital equipment
- Computers and peripherals
- Measuring instruments
- Medical equipment
- Equipment requiring very high impulse attenuation
- Factory automation equipment
- Industrial equipment such as UPS, inverters and converters
- Telecommunications equipment
- Office automation equipment, such as copy and fax machines

Circuit Diagram

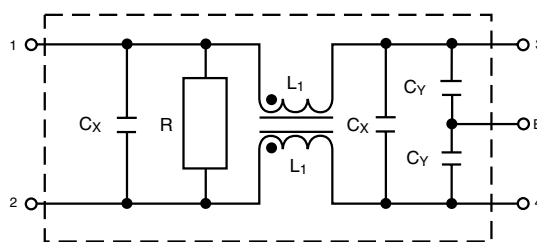

Specifications

Model	Rated Voltage (@ 50/60Hz)	Rated Current	Leakage Current (Max.)	Capacitance		Inductance (L ₁)	Temperature Rise (Max.)
				C _Y	C _X		
62-PMB-300-5-14	250VAC	30A	0.50mA	3300pF	.47uF	1.6mH	45°C
62-PMB-400-5-14		40A				0.8mH	

Note: Test voltage: 1500VAC one minute, line to earth
 Insulation resistance: 300 Mohm min. at 500VDC
 Voltage drop: 1V max.
 Discharge time: 0.4 sec. max.
 Weight: 8.82 ounces (250 grams)

Power Line Filters Single Stage - Higher Current

62-PMB Series

62-PMB-300-5-14 and 62-PMB-400-5-14

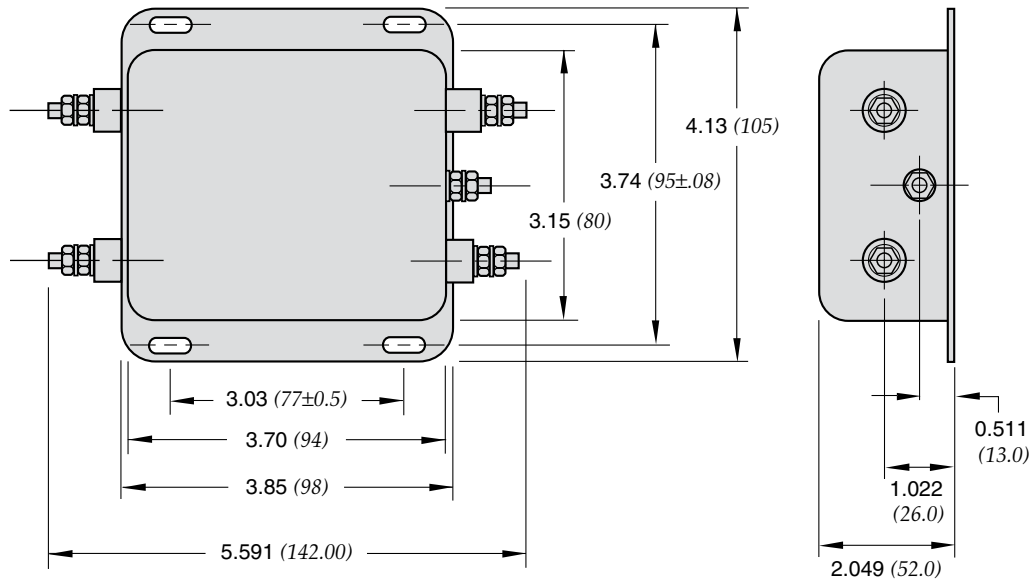

Dimensions in inches (mm)

Normal Mode

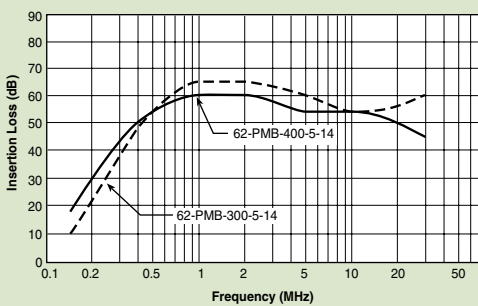
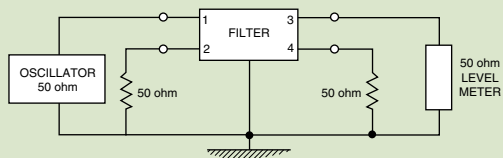

Common Mode

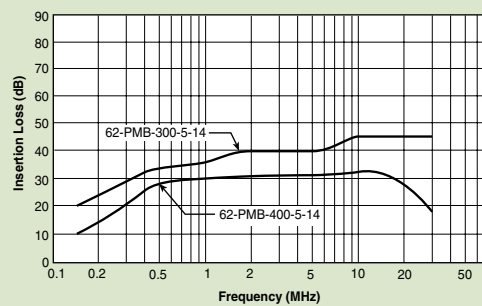
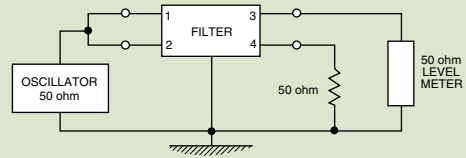

Power Line Filters Single Stage - Higher Current

12-PMB Series

Features

- Space-saving, compact designs
- Suitable for products that must conform to FCC regulations
- Excellent attenuation for high voltage impulse
- Metal case provides effective shielding
- Excellent filtering characteristics for both normal mode and common mode
- Epoxy molded for internal component reliability
- Structure provides effective shielding for noise generated externally and internally
- Designed to be in accordance with VDE 0565 Part 3
- Operating temperature: -25°C to +85°C

Applications

- Digital equipment
- Computers and peripherals
- Measuring instruments
- Medical equipment
- Equipment requiring very high impulse attenuation
- Factory automation equipment
- Industrial equipment such as UPS, inverters and converters
- Telecommunications equipment
- Office automation equipment, such as copy and fax machines



Circuit Diagram

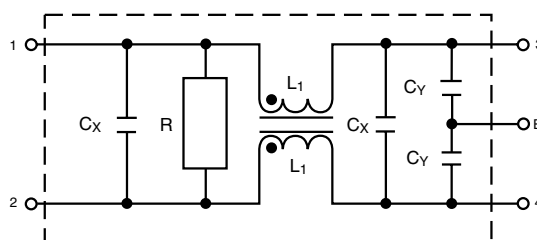

Specifications

Model	Rated Voltage (@ 50/60Hz)	Rated Current	Leakage Current (Max.)	Circuit Diagram	Figure	Temperature Rise (Max.)
12-PMB-025-5-A	120/250VAC	25A	0.5mA	1	A	30°C
12-PMB-030-5-A		30A			B	
12-PMB-035-5-B		35A			C	
12-PMB-050-5-B		50A				
12-PMB-100-8-C		100A				
12-PMB-120-8-C		120A	1.0mA			

Note: Test voltage: 1500VAC one minute, line to earth
 Insulation resistance: 300 Mohm min. at 500VDC
 Voltage drop: 1V max.
 Discharge time: 0.4 sec. max.
 Weight: 8.82 ounces (250 grams)

Power Line Filters Single Stage - Higher Current

12-PMB Series

Figure A

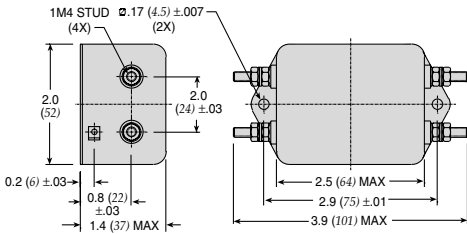

Figure B

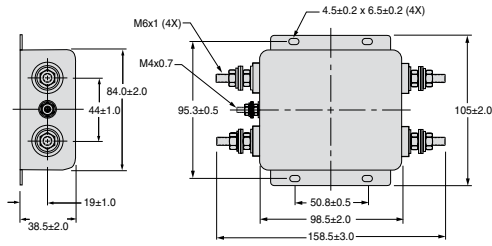
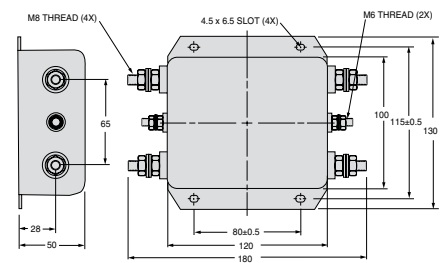
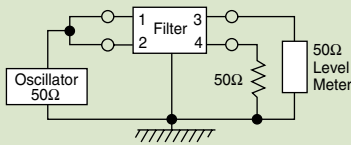

Figure C



Dimensions in inches (mm)

Common Mode



12-PMB-025;-030;-035

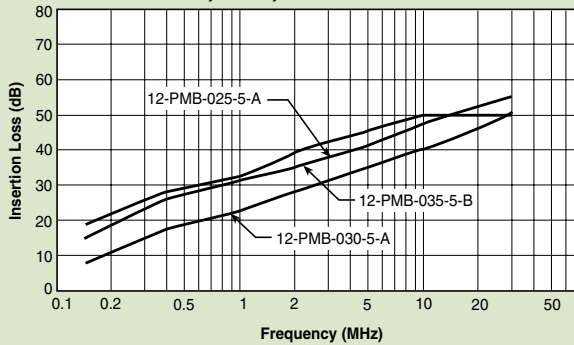

12-PMB-050;-100;-120

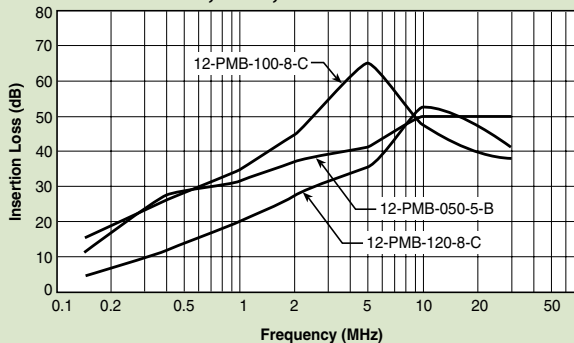

Normal Mode

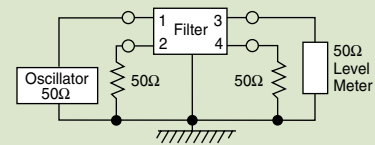

12-PMB-025;-030;-035

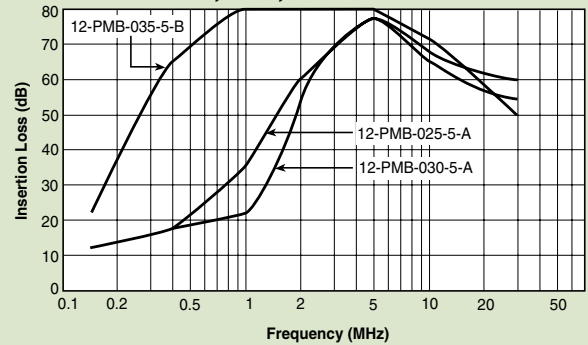

12-PMB-050;-100;-120

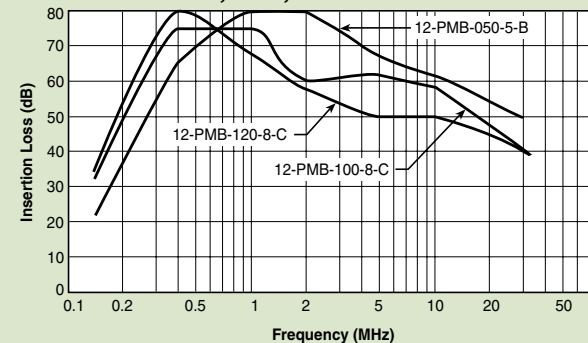

Power Line Filters DC - Higher Current

12-PMF & 12 PMB DC Series

Features

- Space-saving, compact designs
- Suitable for products that must conform to FCC regulations
- Excellent attenuation for high voltage impulse
- Metal case provides effective shielding
- Excellent filtering characteristics for both normal mode and common mode
- Epoxy molded for internal component reliability
- Structure provides effective shielding for noise generated externally and internally
- Designed to be in accordance with VDE 0565 Part 3
- Operating temperature: -40°C to +85°C

Applications

- Digital equipment
- Computers and peripherals
- Measuring instruments
- Equipment requiring very high impulse attenuation
- Factory automation equipment
- Industrial equipment such as UPS, inverters and converters
- Telecommunications equipment



Circuit Diagram

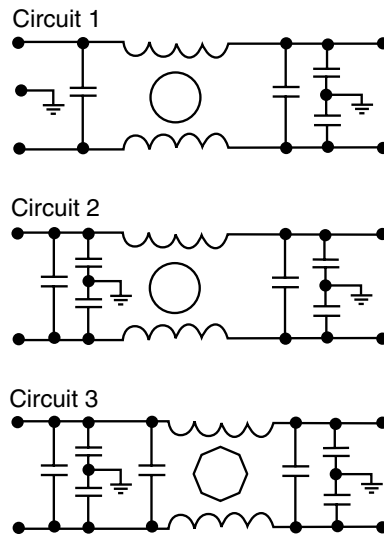

Specifications

Model	Rated Voltage (@ 50/60Hz)	Rated Current	Circuit Diagram	Figure	Temperature Rise (Max.)		
12-PMF-006-DC-C	48/250 VDC	6A	1	A	30°C		
12-PMF-010-DC-C		10A					
12-PMF-015-DC-C		15A					
12-PMF-020-DC-C		20A					
12-PMF-025-DC-D		25A				1	B
12-PMB-025-DC-F				C			
12-PMB-030-DC-F							30A
12-PMB-035-DC-F							35A
12-PMB-040-DC-F							40A
12-PMB-040-DC-B		50A				1	D
12-PMB-050-DC-B			E				
12-PMB-060-DC-B				60A			
12-PMB-080-DC-G				80A			
12-PMB-080-DC-C				2			F
12-PMB-100-DC-C		100A					
12-PMB-120-DC-C		120A					
12-PMB-140-DC-C		140A					
12-PMB-180-DC-E		180A					
12-PMB-200-DC-E		200A	2	G			
12-PMB-260-DC-E						260A	

Note: Test voltage: 1500VAC one minute, line to earth
Insulation resistance: 300 Mohm min. at 500VDC
Voltage drop: 1V max.

Discharge time: 0.4 sec. max.
Weight: 8.82 ounces (250 grams)

Power Line Filters DC - Higher Current

12-PMF & 12-PMB DC Series

Figure B

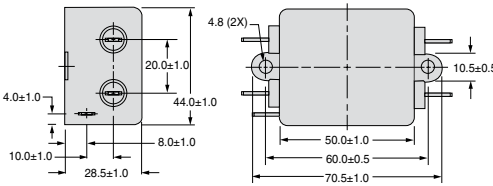

Figure C

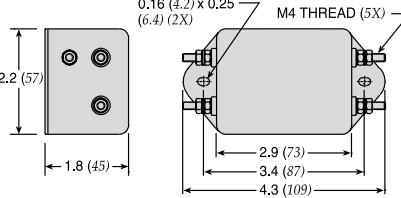

Figure A

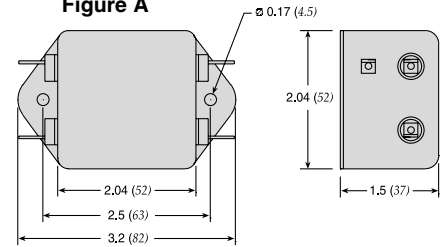

Figure D

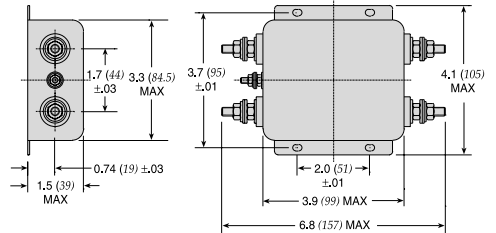

Figure E

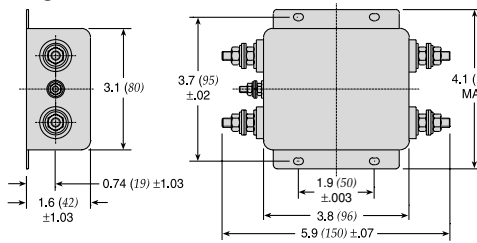

Figure F

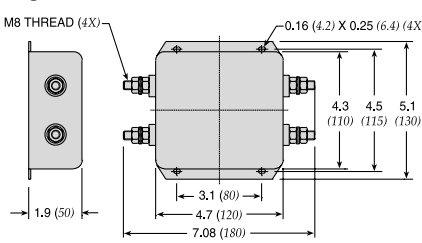
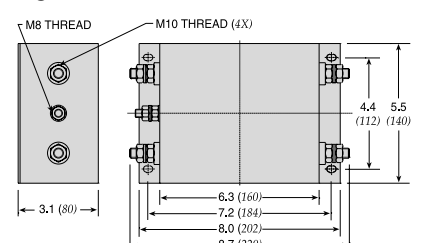
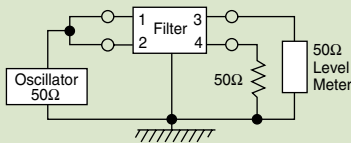

Figure G



Dimensions in inches (mm)

Common Mode



12-PMF-006;-010;-015;-020;-025

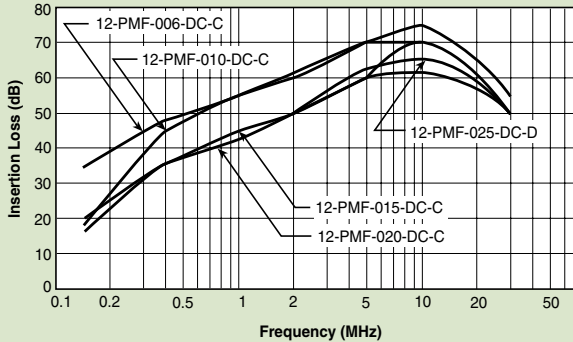

12-PMB-025; thru -260

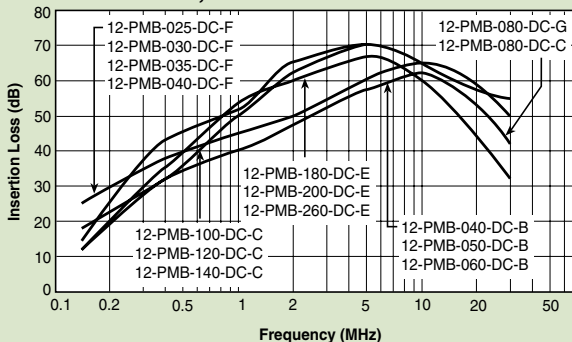

Normal Mode

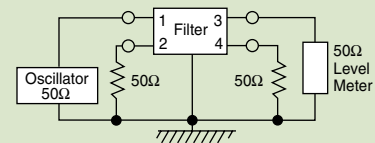

12-PMF-006;-010;-015;-020;-025

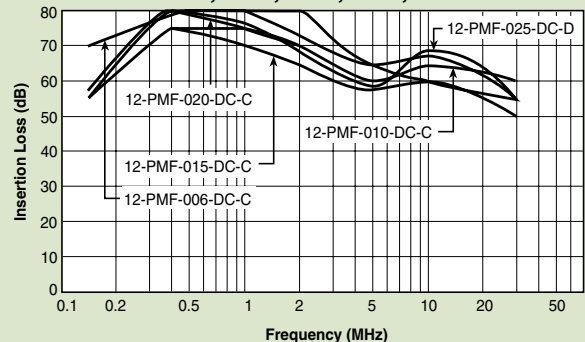

12-PMB-025; thru -260

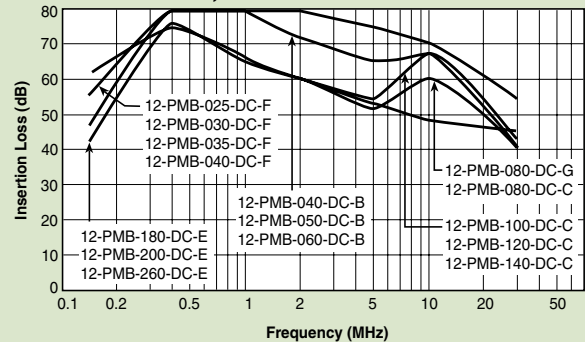

Power Line Filters Dual Stage

62-MMF Series

Features

- Suitable for products that must conform to FCC regulations
- Excellent attenuation for high voltage impulse
- Metal case provides effective EMI shielding
- Two stages for excellent filtering characteristics
- Epoxy molded for reliability
- Structure provides effective shielding for noise generated both externally and internally
- Operating temperature: -25°C to +85°C (including temperature rise, see graph on page PF73)

Applications

- Digital equipment
- Personal computers and peripherals
- Measuring instruments and medical equipment
- Telecommunications equipment
- Equipment requiring very high noise attenuation



Circuit Diagram

62-MMF-XXX-7-11

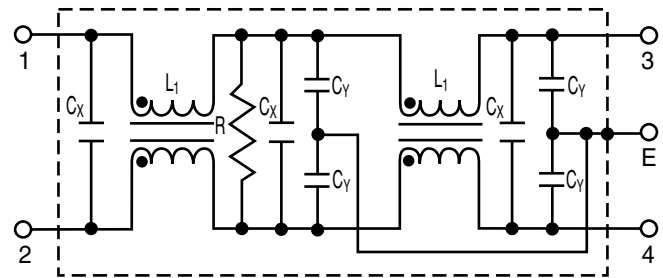

Specifications

Model	Rated Voltage (@ 50/60Hz)	Rated Current	Leakage Current (Max.)	Capacitance			Inductance (L ₁) (2X)	Temperature Rise (Max.)
				C _{Y1}	C _{Y2}	C _X		
62-MMF-030-7-11	250VAC	3A	.7mA	3300pF	1000pF	0.1uF	3.7mH	30°C
62-MMF-050-7-11	250VAC	5A	.7mA	3300pF	1000pF	0.1uF	2.9mH	30°C

Note: All types are designed to meet the requirement of UL 1283, CSA 22.2. VDE 0565-3
 Test voltage: 1500VAC one minute, line to ground
 Insulation resistance: 300 Mohm min. at 500VDC
 Leakage current: 0.7 mA max.
 Voltage drop: 1V max.
 Discharge time: 0.4 sec. max.
 Weight: 6.0 ounces (170 grams)

Power Line Filters Dual Stage

62-MMF Series

Temperature Characteristics

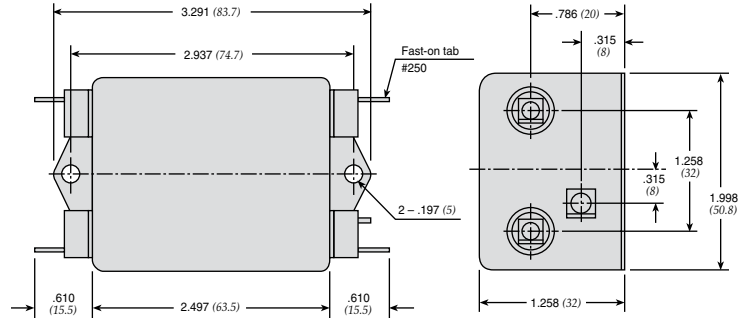
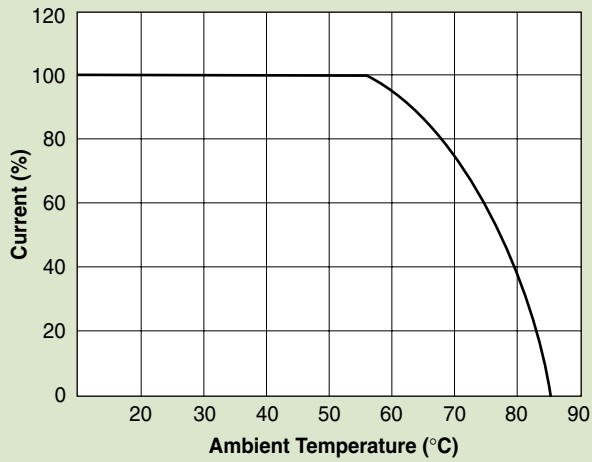

Common Mode

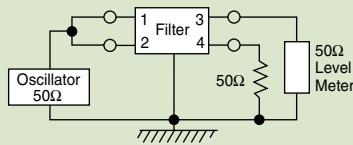

62-MMF

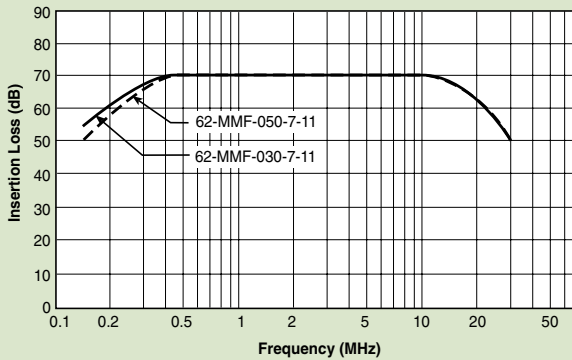

Normal Mode

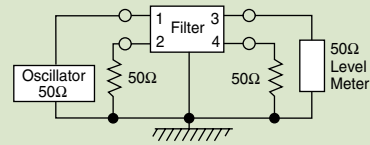

62-MMF

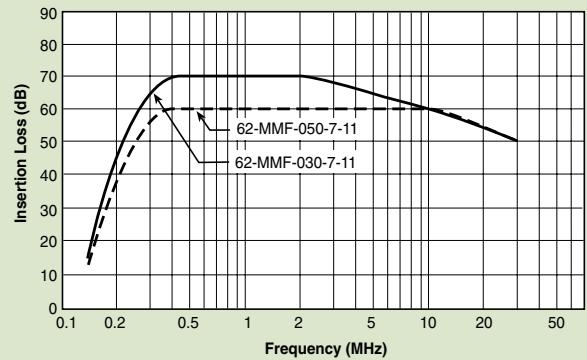

Power Line Filters Dual Stage



12-MMF & 12-MMB Series

Features

- Suitable for products that must conform to FCC regulations
- Excellent attenuation for high voltage impulse
- Metal case provides effective EMI shielding
- Two stages for excellent filtering characteristics
- Structure provides effective shielding for noise generated both externally and internally
- Operating temperature: -40°C to +85°C
- High performance
- Low leakage current

Applications

- Digital equipment
- Switching power supplies
- Personal computers and peripherals
- Measuring instruments and medical equipment
- Telecommunications equipment
- Equipment requiring very high noise attenuation

Circuit Diagram

Circuit 1

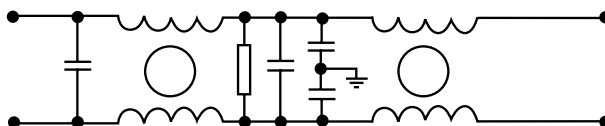

Circuit 2

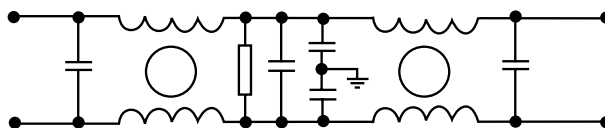

Circuit 3

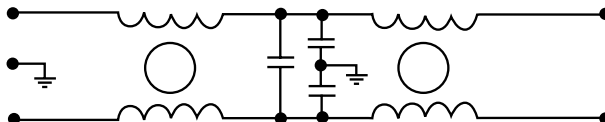

Specifications

Model	Rated Voltage (@ 50/60Hz)	Rated Current	Leakage Current (Max.)	Circuit Diagram	Figure	Temperature Rise (Max.)	
12-MMF-002-5-F	120/250VAC	2A	0.25mA@120VAC/ 0.5mA@250VAC	1	A	30°C	
12-MMF-003-5-F		3A			A		
12-MMF-003-5-A					B		
12-MMF-006-5-F		6A		2	A		
12-MMF-006-5-G					C		
12-MMF-008-5-B		8A			A		
12-MMF-010-5-F		10A			A1		
12-MMF-010-5-G							C
12-MMF-010-5-B							
12-MMF-012-5-B		12A			D		
12-MMB-015-5-E		15A			G		
12-MMB-020-5-F		20A			E		
12-MMB-030-5-D		30A		F			
12-MMB-050-5-C		50A					

Note: All types are designed to meet the requirement of UL 1283, CSA 22.2, VDE 0565-3
 Test voltage: 1500VAC one minute, line to ground
 Insulation resistance: 300 Mohm min. at 500VDC
 Voltage drop: 1V max.
 Discharge time: 0.4 sec. max.

Power Line Filters Dual Stage

12-MMF & 12-MMB Series

Figure B

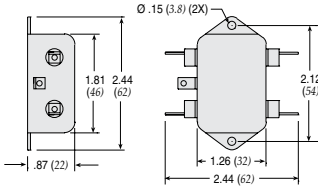

Figure C

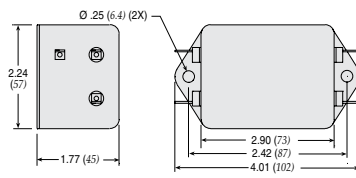

Figure A

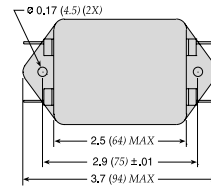

Figure A1

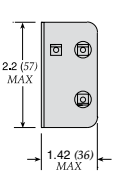

Figure D

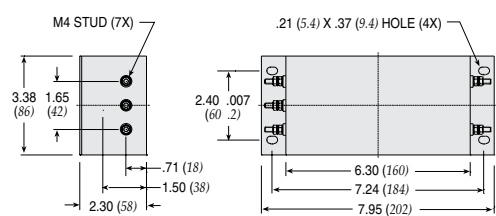

Figure E

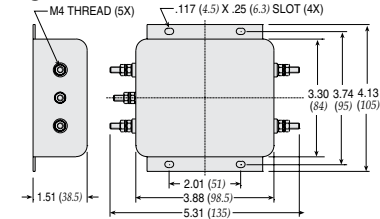

Figure F

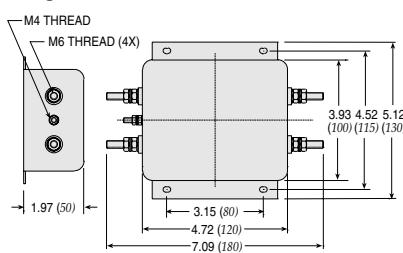
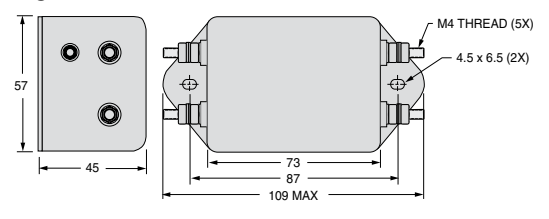
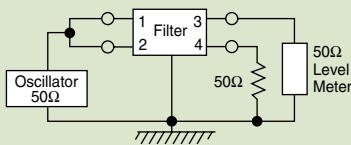

Figure G



Dimensions in inches (mm)

Common Mode



12-MMF-002;-003;-006;-008

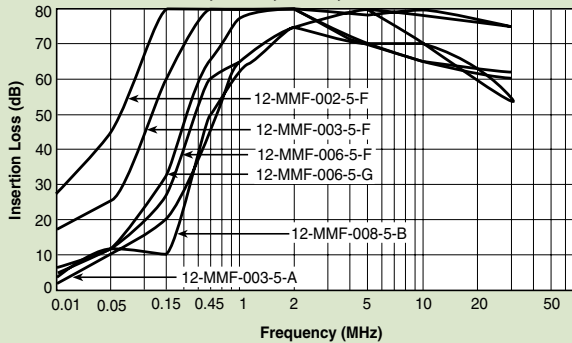

12-MMF-010;-012;-015;-020;-030;-050

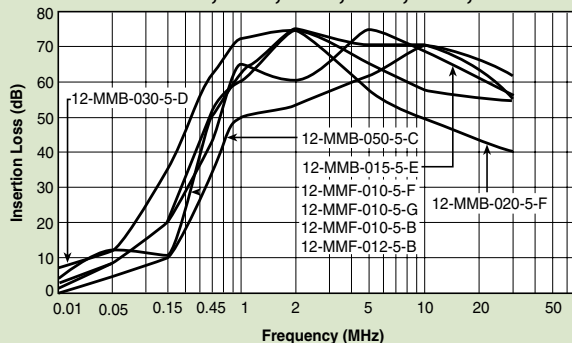

Normal Mode

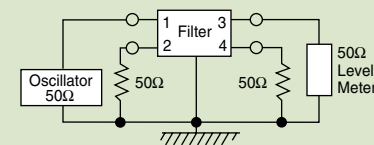

12-MMF-002;-003;-006;-008

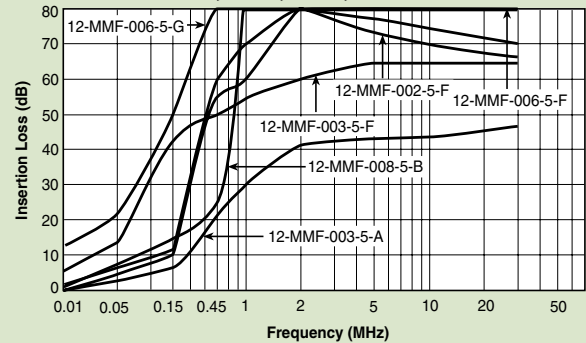

12-MMF-010;-012;-015;-020;-030;-050

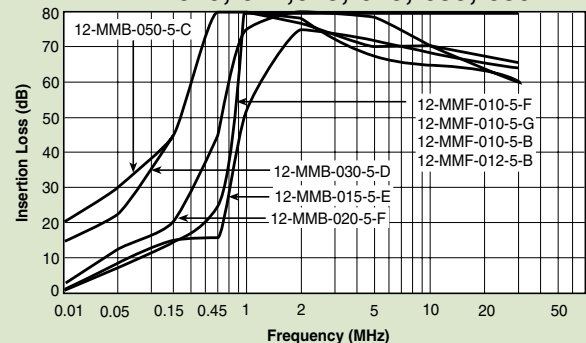

Power Line Filters Dual Stage



12-MMF & 12-MMB Series

Features

- Suitable for products that must conform to FCC regulations
- Excellent attenuation for high voltage impulse
- Metal case provides effective EMI shielding
- Two stages for excellent filtering characteristics
- Structure provides effective shielding for noise generated both externally and internally
- Operating temperature: -40°C to +85°C
- High performance

Applications

- Digital equipment
- Personal computers and peripherals
- Measuring instruments and medical equipment
- Telecommunications equipment
- Equipment requiring very high noise attenuation

Circuit Diagram

Circuit 1

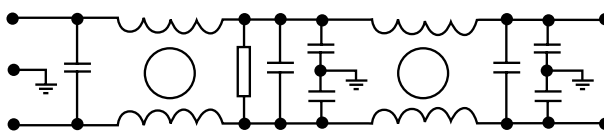

Circuit 2

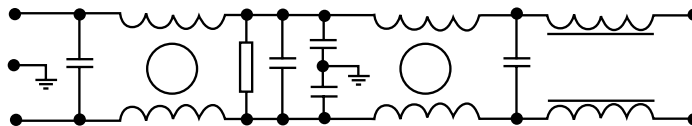

Specifications

Model	Rated Voltage (@ 50/60Hz)	Rated Current	Leakage Current (Max.)	Circuit Diagram	Figure	Temperature Rise (Max.)
12-MMF-003-11-F	120/250VAC	3A	1.5mA	1	A	30°C
12-MMF-006-11-F		6A			C	
12-MMF-010-11-F		10A			B	
12-MMB-015-11-G		15A		2	D	
12-MMB-020-11-D		20A			E	
12-MMB-030-11-D		30A			F	
12-MMB-040-11-B		40A		1		
12-MMB-040-11-E						
12-MMB-050-11-H		50A				

Note: All types are designed to meet the requirement of UL 1283, CSA 22.2. VDE 0565-3
 Test voltage: 1500VAC one minute, line to ground
 Insulation resistance: 300 Mohm min. at 500VDC
 Leakage current: 0.7 mA max.
 Voltage drop: 1V max.
 Discharge time: 0.4 sec. max.
 Weight: 6.0 ounces (170 grams)

Power Line Filters Dual Stage

12-MMF & 12-MMB Series

Figure A

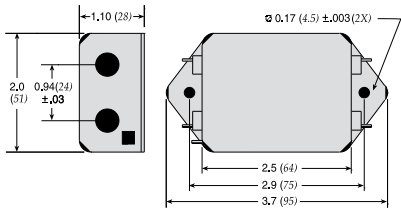

Figure B

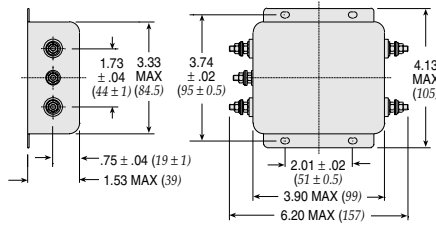

Figure C

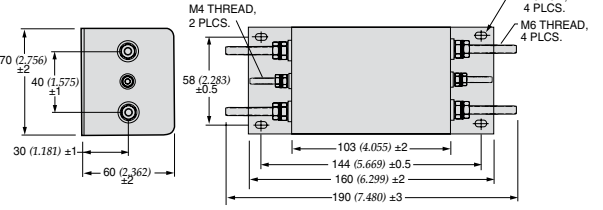

Figure D

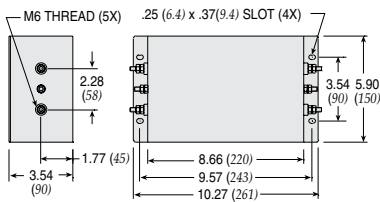

Figure E

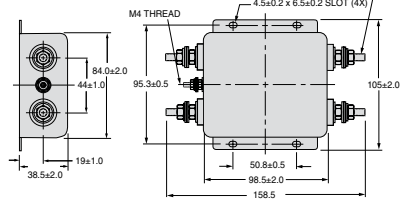
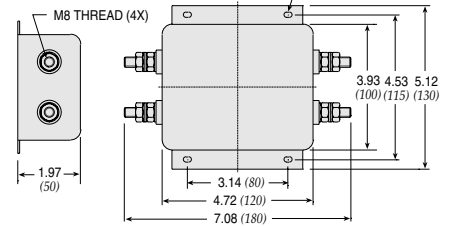
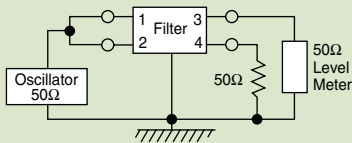

Figure F



Dimensions in inches (mm)

Common Mode



12-MMF/MMB-003;-006;-010;-012;-015

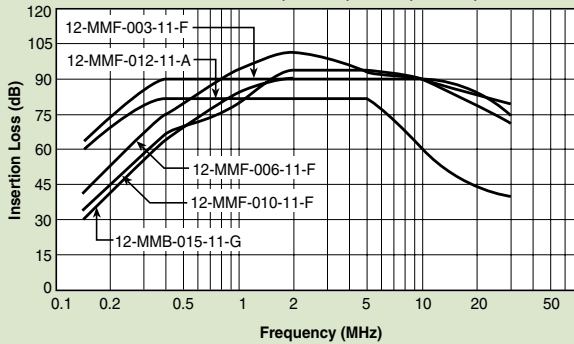

12-MMB-020;-030;-040;-050

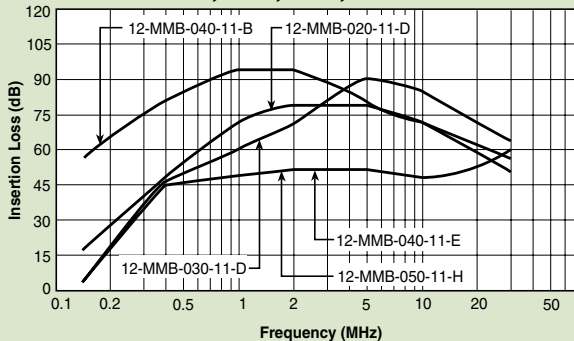

Normal Mode

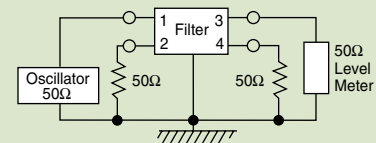

12-MMF/MMB-003;-006;-010;-012;-015

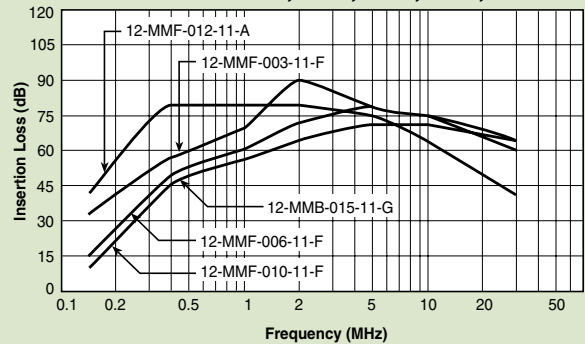

12-MMB-020;-030;-040;-050

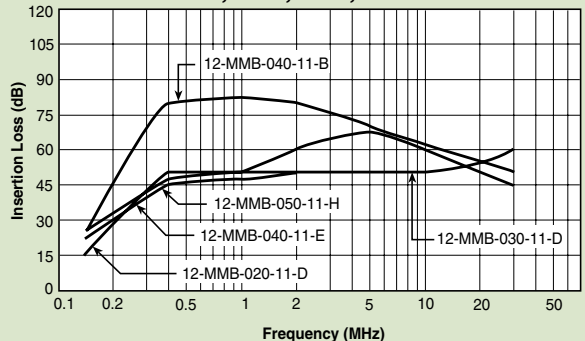

Power Line Filters Dual Stage

12-MMF & 12-MMB Series

Features

- Suitable for products that must conform to FCC regulations
- Excellent attenuation for high voltage impulse
- Metal case provides effective EMI shielding
- Two stages for excellent filtering characteristics
- Epoxy molded for reliability
- Structure provides effective shielding for noise generated both externally and internally
- Operating temperature: -25°C to +85°C

Applications

- Digital equipment
- Personal computers and peripherals
- Measuring instruments and medical equipment
- Telecommunications equipment
- Equipment requiring very high noise attenuation



Circuit Diagram

Circuit 1

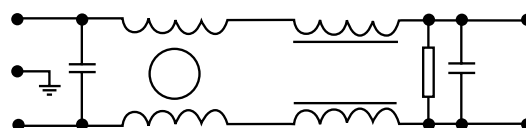

Circuit 2

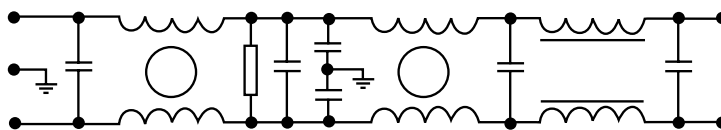

Circuit 3

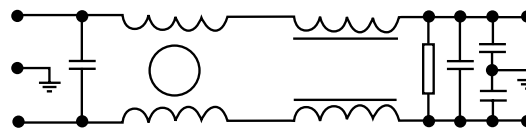

Specifications

Model	Rated Voltage (@ 50/60Hz)	Rated Current	Leakage Current (Max.)	Circuit Diagram	Figure	Temperature Rise (Max.)
12-MMF-001-5-F	120/250VAC	1A	0.5mA	3	A	30°C
12-MMF-003-5-G		3A			5uA	
12-MMF-003-2-G			6A	0.5mA		
12-MMF-006-5-G		10A	D			
12-MMB-010-5-D		15A				
12-MMB-015-5-E		20A				
12-MMB-020-5-E		30A				

Note: All types are designed to meet the requirement of UL 1283, CSA 22.2, VDE 0565-3
 Test voltage: 1500VAC one minute, line to ground
 Insulation resistance: 300 Mohm min. at 500VDC
 Leakage current: 0.7 mA max.
 Voltage drop: 1V max.
 Discharge time: 0.4 sec. max.
 Weight: 6.0 ounces (170 grams)

Power Line Filters Dual Stage

12-MMF & 12-MMB Series

Figure A

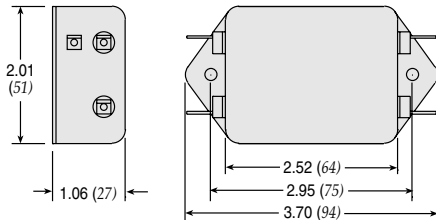

Figure B

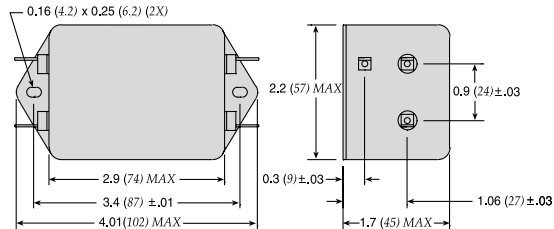

Figure C

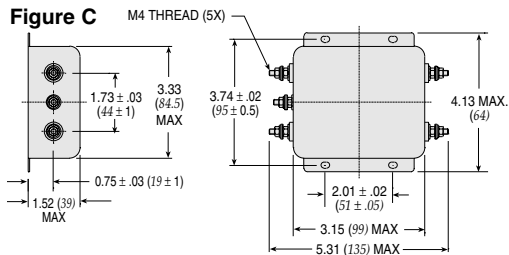
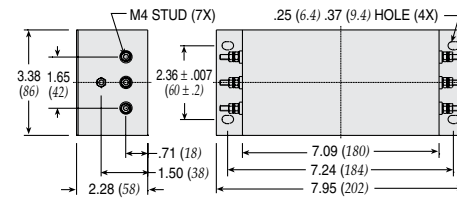
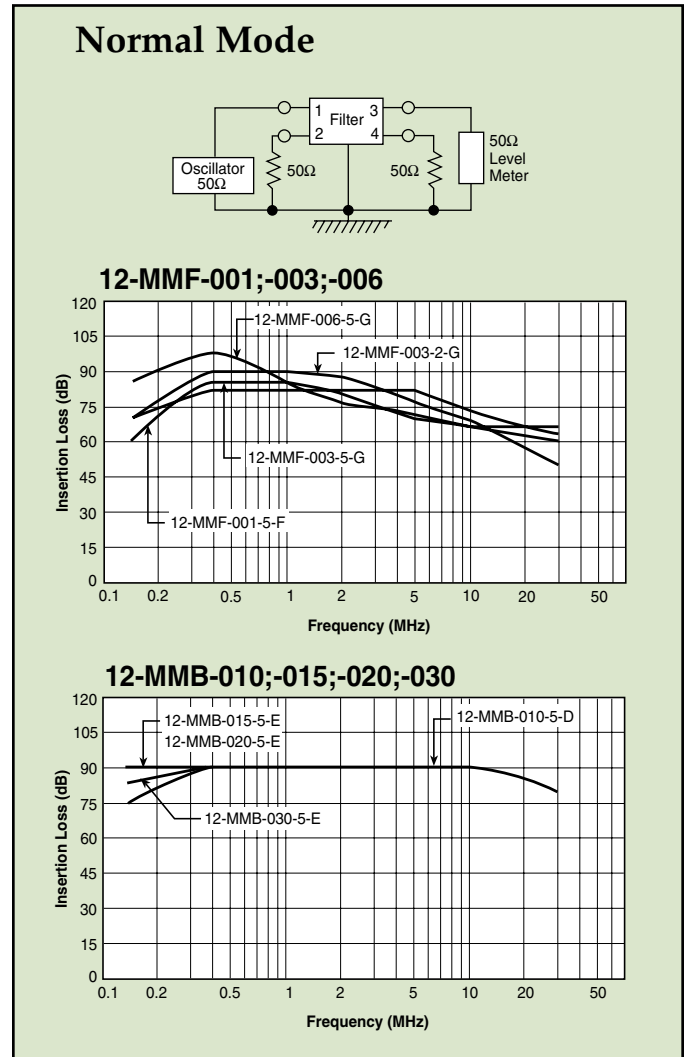
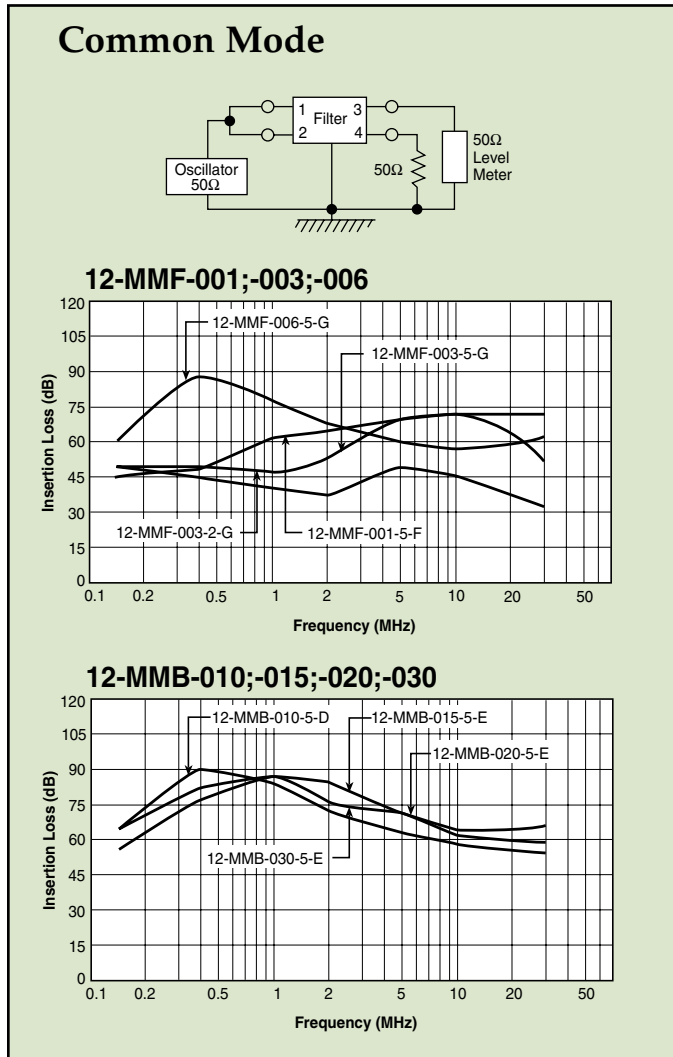

Figure D



Dimensions in inches (mm)



Power Line Filters Three Phase

Low Current/High Performance

62-PMB/63-PMF Series

Features

- Excellent attenuation for high voltage impulse
- Effective for both balanced and unbalanced three-phase loads
- Metal case provides effective EMI shielding
- Epoxy molded for internal component reliability
- Compact and economical
- Excellent filtering characteristics for both normal and common mode
- Various current ratings available: 3, 5, 8 and 16 Amps
- Safety agency approvals pending
- Operating temperature: -25°C to +85°C (including temperature rise, see graph on page PF81)

Applications

- Digital equipment
- Industrial equipment (UPS, inverters and converters)
- Automation equipment
- Computerized washing machines



Circuit Diagram

62-PMB-050-6-12 (5 Amp Delta)

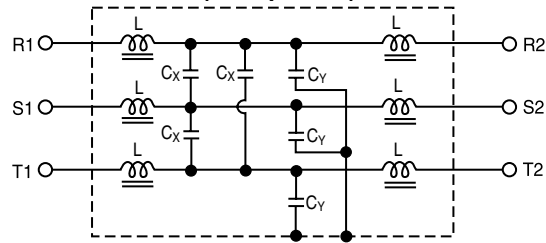

63-PMF-030-8-14 and 63-PMF-080-8-14 (3 and 8 Amp Wye)

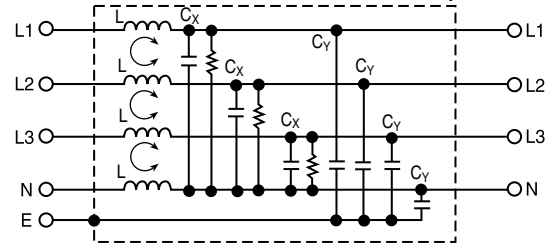

63-PMF-160-9-21 (16 Amp Wye)

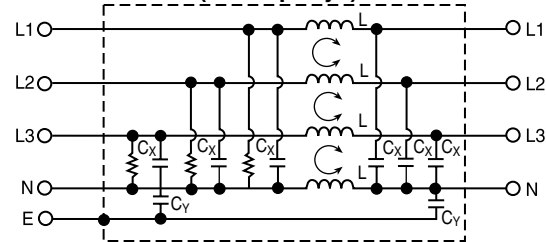

Specifications

Model	Rated Voltage (@ 50/60Hz)	Rated Current	Leakage Current (Max.)	Capacitance		Inductance (L ₁)	Temperature Rise (Max.)
				C _Y	C _X		
62-PMB-050-6-12	250VAC	5A	0.6mA	2200pF	0.22uF	115mH	45°C
63-PMF-030-8-14	480VAC	3A	1.0mA	4700pF (4X)	470uF (3X)	1.0mH (4X)	30°C
63-PMF-080-8-14		8A				0.74mH (4X)	40°C
63-PMF-160-9-21		16A	3.0mA			0.015uF (2X)	1.0uF (6X)

Note: Test Voltage 1500VAC one minute, line to ground.
 Insulation Resistance: 300 MΩ min. at 500VDC.
 Voltage Drop: 1V max. at rated current.
 Weight: 8.82 ounces (250 grams) for 63-PMF-030-8-14 and 63-PMF-080-8-14
 19.4 ounces (550 grams) for 62-PMB-050-6-12
 51.5 ounces (1450 grams) for 63-PMF-160-9-21

Power Line Filters Three Phase

Low Current/High Performance

62-PMB/63-PMF Series

62-PMB-050-6-12 (5 Amp)

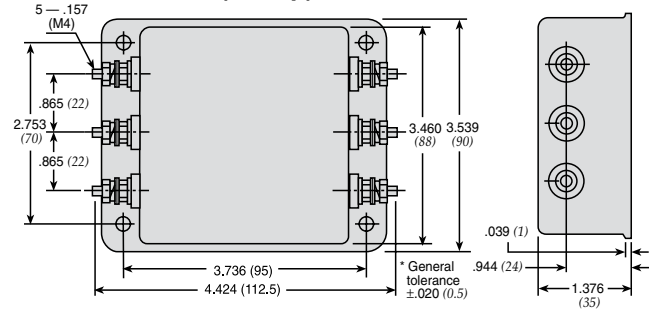

63-PMF-030-8-14 and 63-PMF-080-8-14 (3 and 8 Amp)

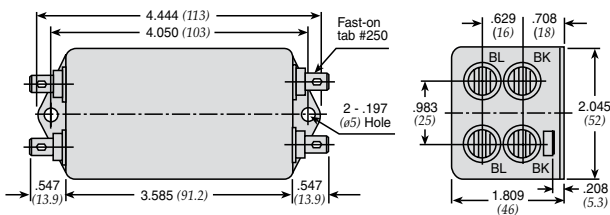

Dimensions in inches (mm)

63-PMF-160-9-21 (16 Amp)

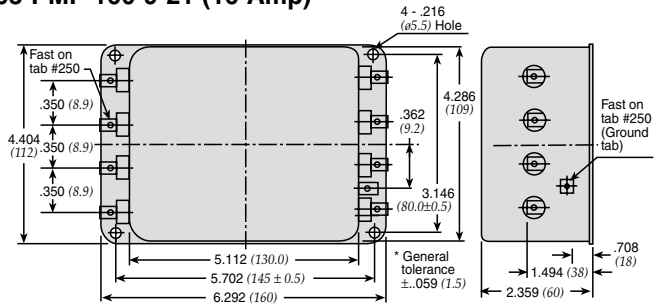

Normal Mode

62-PMB-050-6-12 (5 Amp)

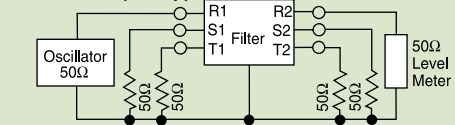

63-PMF (3, 8 and 16 Amp)

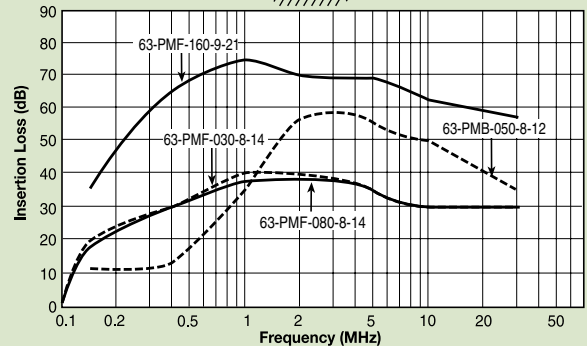
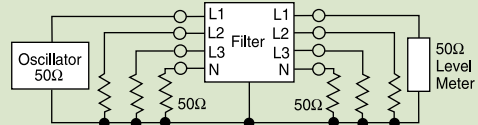

Common Mode

62-PMB-050-6-12 (5 Amp)

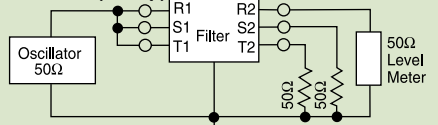

63-PMF (3, 8 and 16 Amp)

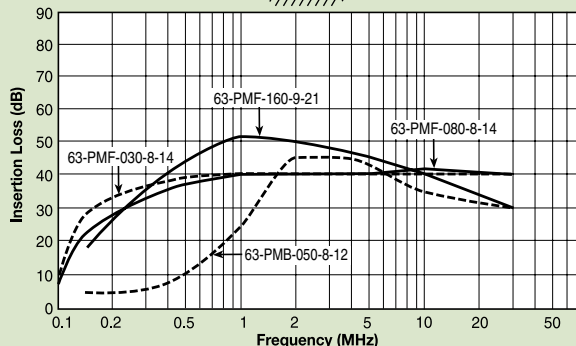
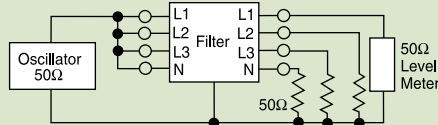

Power Line Filters Three Phase



13-PWF/PWL/PWB Series

Features

- Excellent attenuation for high voltage impulse
- Effective for both balanced and unbalanced three-phase loads
- Metal case provides effective EMI shielding
- Epoxy molded for internal component reliability
- Suitable for both Wye and Delta connection
- Excellent filtering characteristics for both normal and common mode
- Operating temperature: -40°C to +85°C
- Designed for 3-phase 4-line power supply systems

Applications

- Digital equipment
- Industrial equipment (UPS, inverters and converters)
- Automation equipment
- Computerized washing machines

Circuit Diagram

Circuit 1

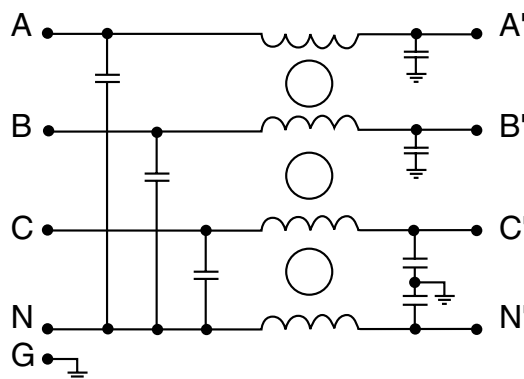

Circuit 2

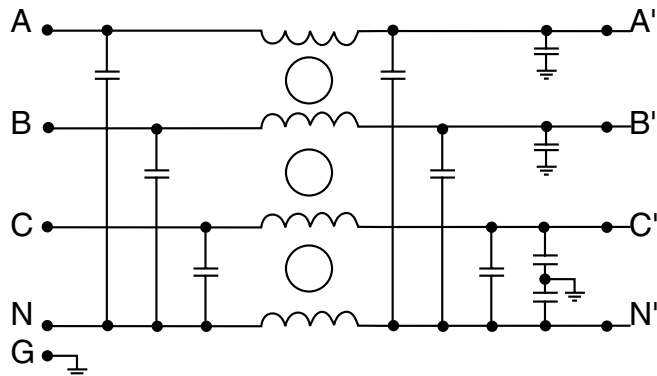

Specifications

Model	Rated Voltage (@ 50/60Hz)	Rated Current	Leakage Current (Max.)	Circuit Diagram	Figure	Temperature Rise (Max.)
13-PWF-005-12-H	440/250VAC	5A	1.5mA	1	A	30°C
13-PWL-005-12-C					B	
13-PWF-010-12-H		10A			A	
13-PWL-010-12-C					B	
13-PWB-010-12-D		2		30A	C	
13-PWB-015-12-D						
13-PWB-020-12-D						
13-PWB-025-12-D						
13-PWB-030-12-D						

Note: Test Voltage 1500VAC one minute, line to ground.
Insulation Resistance: 300 MΩ min. at 500VDC.
Voltage Drop: 1V max. at rated current.

Power Line Filters Three Phase

13-PWF/PWL/PWB Series

Figure A

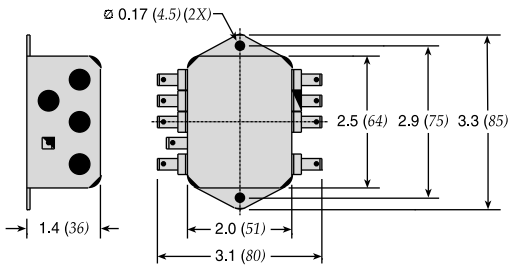

Figure B

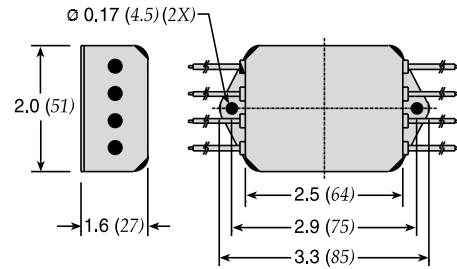
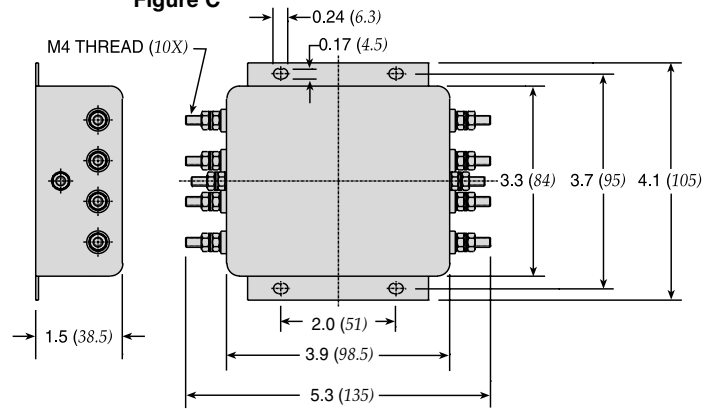
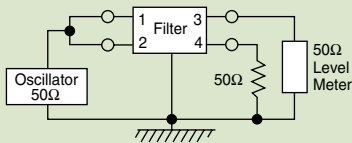

Figure C



Dimensions in inches (mm)

Common Mode



13-PWF-005;-010;-PWL-005;-010;-PWB-010

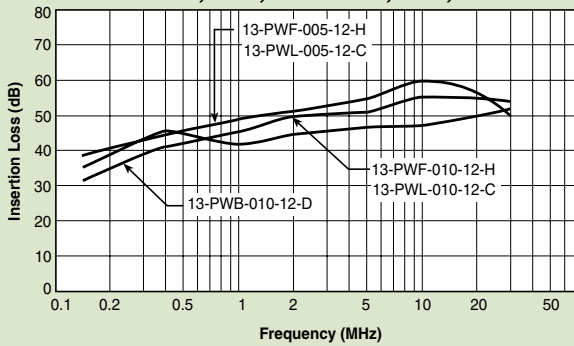

13-PWB-015;-020;-025;-030

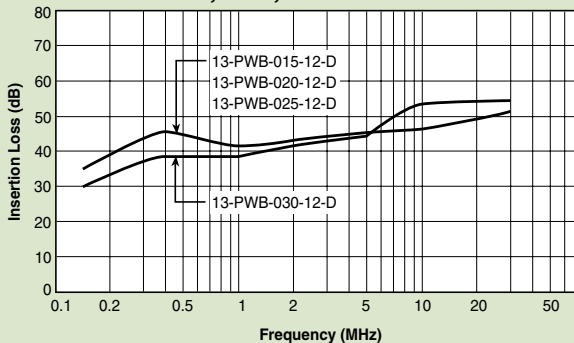

Normal Mode

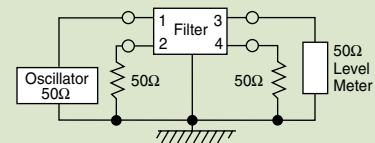

13-PWF-005;-010;-PWL-005;-010;-PWB-010

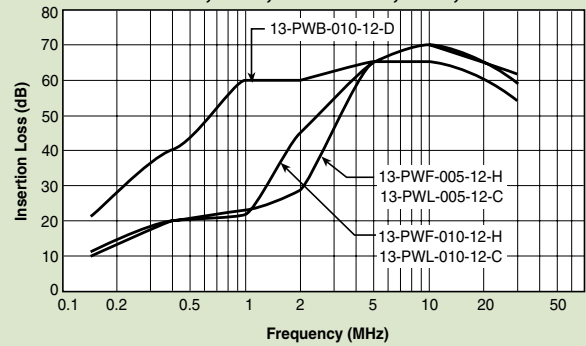

13-PWB-015;-020;-025;-030

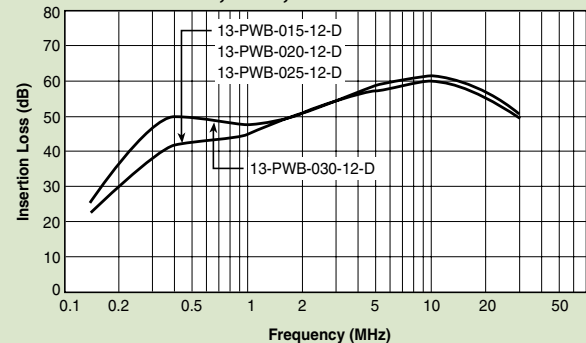

Power Line Filters Three Phase

High Performance

13-PDF/PDL/PDB Series

Features

- Excellent attenuation for high voltage impulse
- Effective for both balanced and unbalanced three-phase loads
- Metal case provides effective EMI shielding
- Epoxy molded for internal component reliability
- Compact and economical
- Excellent filtering characteristics for both normal and common mode
- Operating temperature: -40°C to +85°C
- Designed for 3-phase, 3-Delta connection system

Applications

- Digital equipment
- Industrial equipment (UPS, inverters and converters)
- Automation equipment
- Switching power supplies



Circuit Diagram

Circuit 1

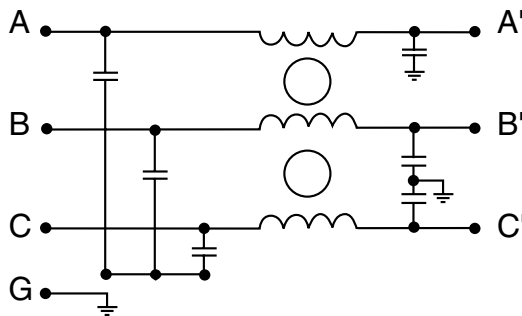

Circuit 2

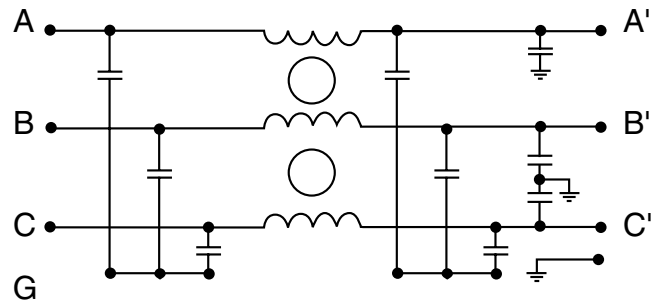

Specifications

Model	Rated Voltage (@ 50/60Hz)	Rated Current	Leakage Current (Max.)	Circuit Diagram	Figure	Temperature Rise (Max.)
13-PDF-005-11-J	440/250VAC	5A	1.5mA	1	A	30°C
13-PDL-005-11-D					B	
13-PDF-010-11-J		10A			A	
13-PDL-010-11-D					B	
13-PDB-010-11-D		2		30A	C	
13-PDB-015-11-D						
13-PDB-020-11-D						
13-PDB-025-11-D						
13-PDB-030-11-D						

Note: Test Voltage 1500VAC one minute, line to ground.
Insulation Resistance: 300 MΩ min. at 500VDC.
Voltage Drop: 1V max. at rated current.

Power Line Filters Three Phase

High Performance

13-PDF/PDL/PDB Series

Figure A

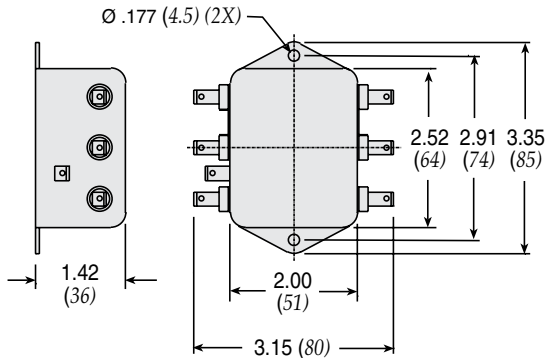

Dimensions in inches (mm)

Figure B

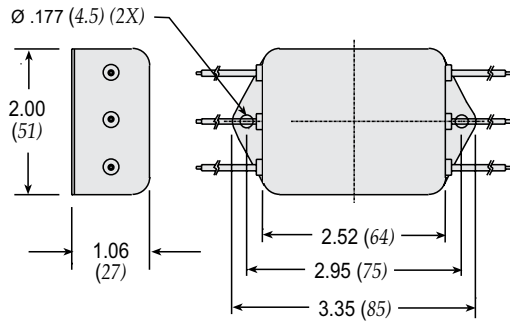
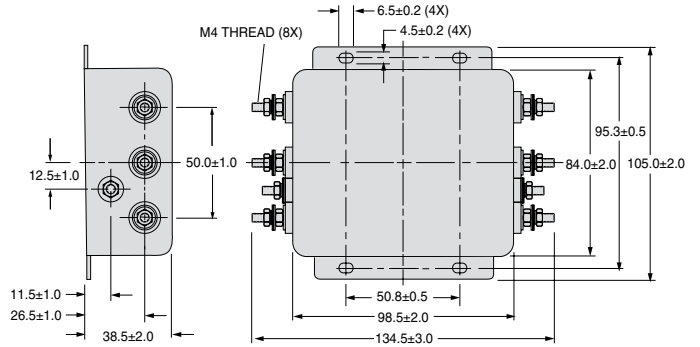
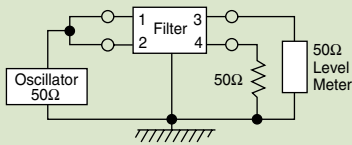

Figure C



Common Mode



13-PDF-005;-010; PDL-005;-010 PDB-010

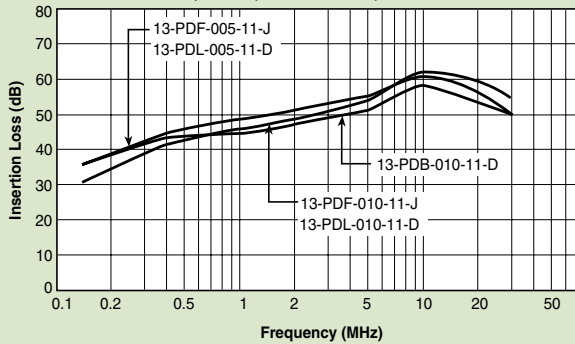

13-PDB-015;-020;-025;-030

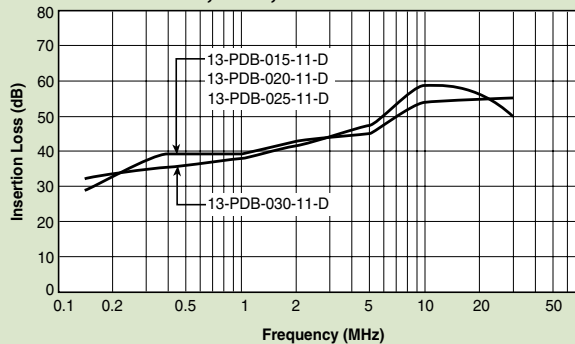

Normal Mode

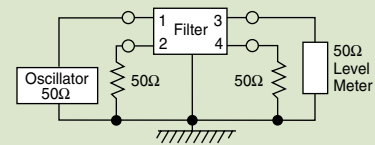

13-PDF-005;-010; PDL-005;-010 PDB-010

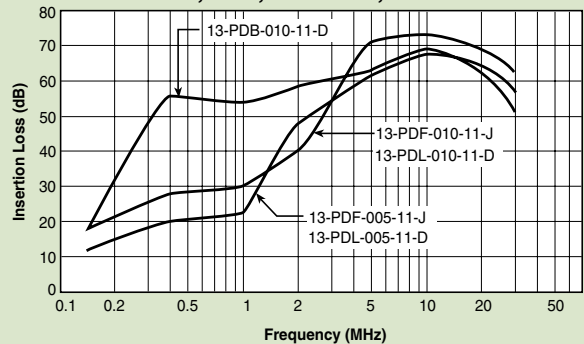

13-PDB-015;-020;-025;-030

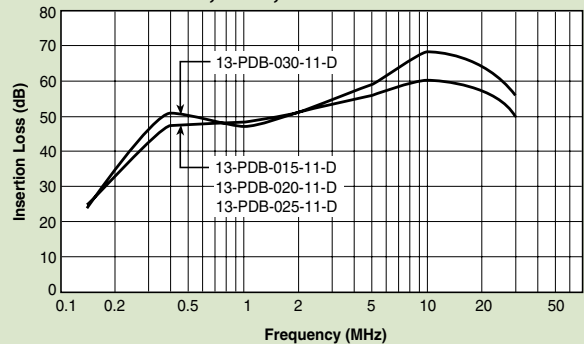

Power Line Filters Three Phase

High Performance

13-PWB Series

Features

- Excellent attenuation for high voltage impulse
- Metal case provides effective EMI shielding
- Epoxy molded for internal component reliability
- Excellent filtering characteristics for both normal and common mode
- Various current ratings available: from 5 to 150 Amps
- Operating temperature: -40°C to +85°C
- Designed for 3-phase, 4-line power systems

Applications

- Power supplies for data systems
- Industrial equipment (UPS, inverters and converters)
- Automation equipment
- Telecommunications systems and equipment



Circuit Diagram

Circuit 1

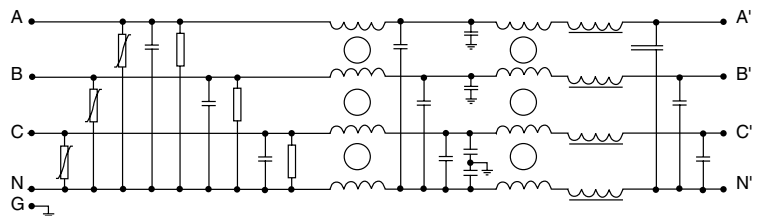

Circuit 2

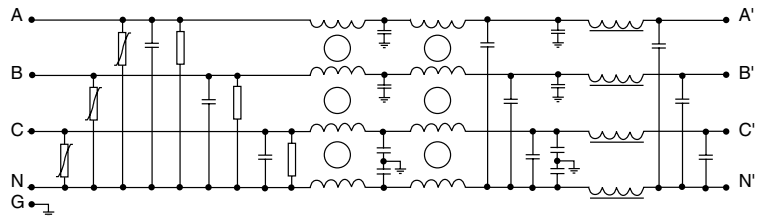

Specifications

Model	Rated Voltage (@ 50/60Hz)	Rated Current	Leakage Current (Max.)	Circuit Diagram	Temperature Rise (Max.)
13-PWB-005-12-A	480/277VAC	5A	4.5mA	1	30°C
13-PWB-010-12-B		10A			
13-PWB-020-12-B		20A			
13-PWB-035-12-C		35A			
13-PWB-050-13-C		50A	9.0mA	2	
13-PWB-080-14-D		80A	20mA		
13-PWB-100-14-D		100A			
13-PWB-150-14-E		150A			

Note: Test Voltage 1500VAC one minute, line to ground.
Insulation Resistance: 300 MΩ min. at 500VDC.
Voltage Drop: 1V max. at rated current.

Power Line Filters Three Phase

High Performance

13-PWB Series

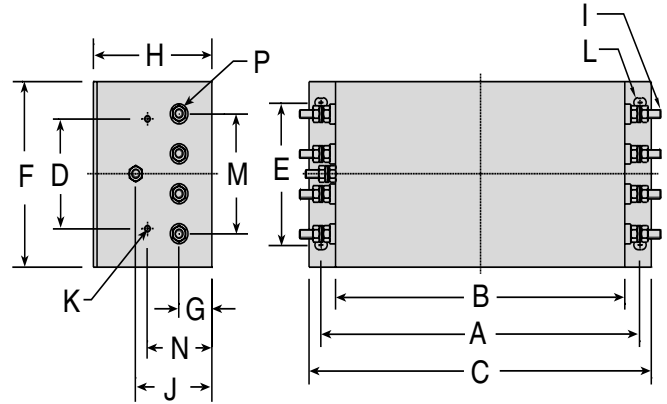

Dimensions

Dimensions in inches (mm)

Model	A	B	C	D	E	F	G	H	I	J	K	M	N	P	L						
13-PWB-005-12-A	7.2 (184)	6.3 (160)	7.9 (202)	2.4 (60)	1.7 (44)	3.5 (86)	.70 (18)	2.3 (58)	M4	1.5 (38)	-	-	-	M4	.25 x .37 (6.4 x 9.4)						
13-PWB-010-12-B	9.6 (243)	8.7 (220)	10.3 (261)			3.9 (100)	.98 (25)			3.5 (90)					1.8 (45)	M6	2.3 (58)	2.9 (74)	1.9 (49)	M6	.25 x .37 (6.4 x 9.5)
13-PWB-020-12-B						2.5 (64)									M6		2.5 (64)				.25 x .38 (6.4 x 9.6)
13-PWB-035-12-C	13.9 (354)	12.6 (320)	15.1 (384)	3.1 (81)	3.8 (96)	4.9 (125)	1.2 (30)	3.9 (100)	M8	2.4 (62)	M4	3.4 (86)	2.2 (56)	M8		.25 x .38 (6.4 x 9.7)					
13-PWB-050-13-C				2.5 (64)	M8	2.5 (64)									.25 x .38 (6.4 x 9.8)						
13-PWB-080-14-D				2.5 (64)		M8									2.5 (64)	.25 x .39 (6.4 x 9.9)					
13-PWB-100-14-D	7.5 (190)	8.7 (220)	1.4 (35)	2.4 (61)	M8		2.4 (61)	M8	2.4 (61)	M8	2.4 (61)	M8	2.4 (61)	M8	.25 x .36 (6.4 x 9.10)						
13-PWB-150-14-E						.25 x .36 (6.4 x 9.11)															

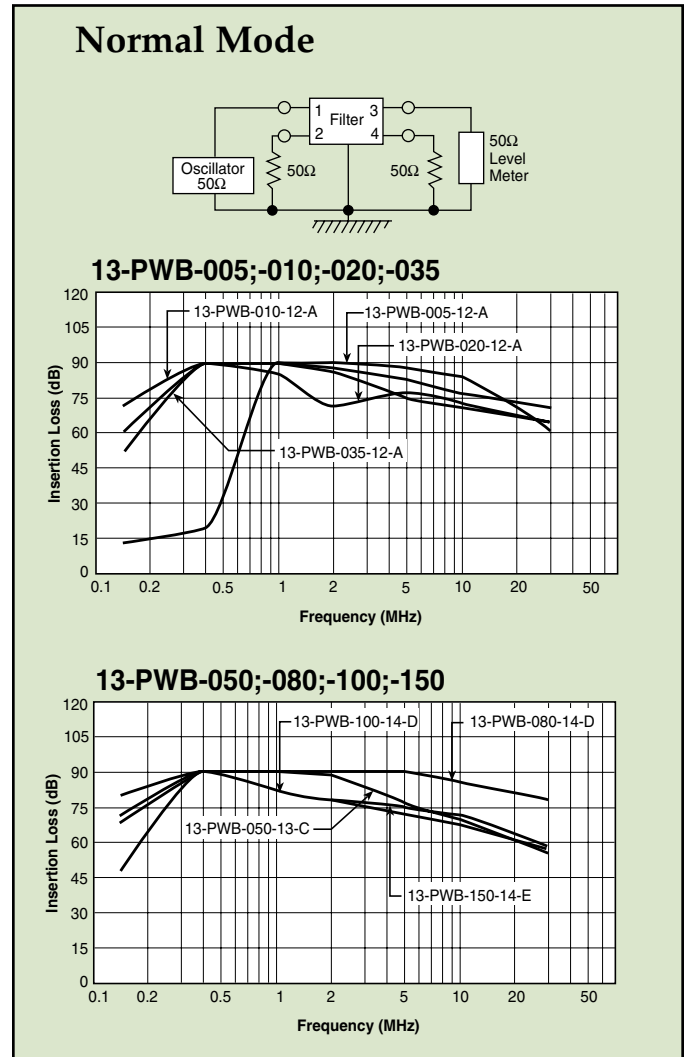
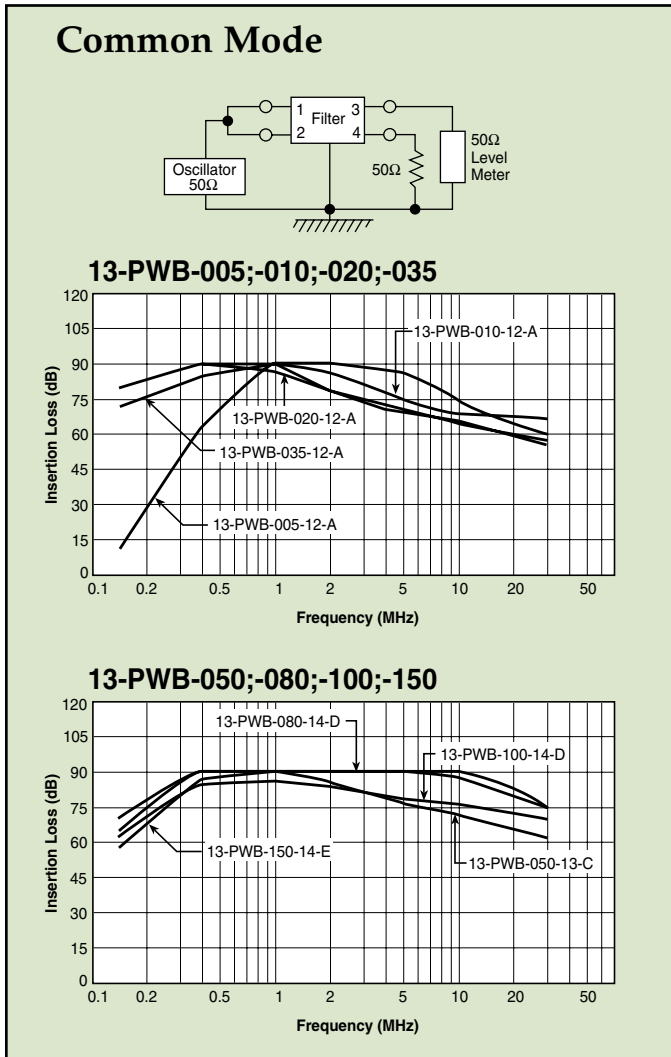

Power Line Filters Three Phase

High Performance

13-PDB Series

Features

- Excellent attenuation for high voltage impulse
- Metal case provides effective EMI shielding
- Epoxy molded for internal component reliability
- Excellent filtering characteristics for both normal and common mode
- Various current ratings available: from 5 to 200 Amps
- Operating temperature: -40°C to +85°C
- Designed for 3-phase, 3-line connection systems

Applications

- Digital equipment
- Industrial equipment (UPS, inverters and converters)



Circuit Diagram

Circuit 1

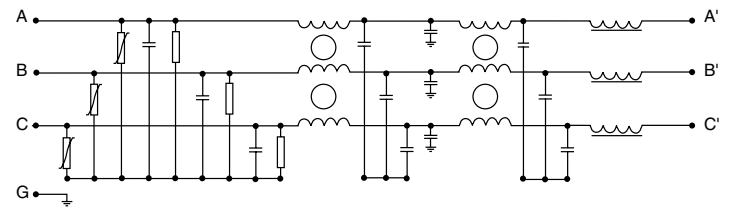

Circuit 2

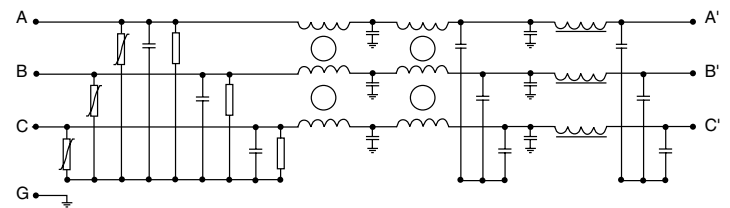

Specifications

Model	Rated Voltage (@ 50/60Hz)	Rated Current	Leakage Current (Max.)	Circuit Diagram	Temperature Rise (Max.)
13-PDB-005-12-A	480/277VAC	5A	4.5mA	1	30°C
13-PDB-010-12-A		10A			
13-PDB-020-12-B		20A			
13-PDB-035-12-B		35A			
13-PDB-050-12-B		50A			
13-PDB-080-13-C		80A	9.0mA	1	
13-PDB-100-14-C		100A			
13-PDB-150-14-C		150A			
13-PDB-200-14-D		200A			

Note: Test Voltage 2250VDC one minute, line to ground.
Insulation Resistance: 500MΩ.

Power Line Filters Three Phase

High Performance

13-PDB Series

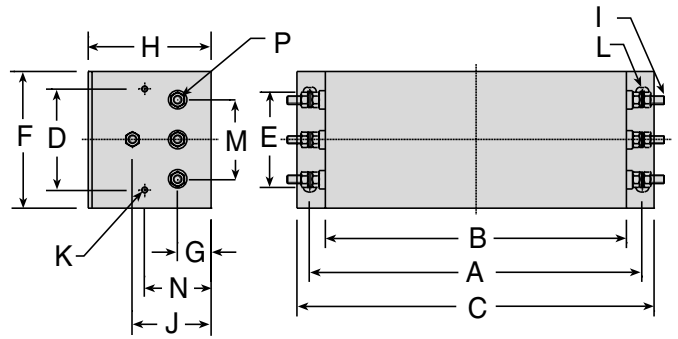

Dimensions

Dimensions in inches (mm)

Model	A	B	C	D	E	F	G	H	I	J	K	M	N	P	L
13-PDB-005-12-A	7.2 (184)	6.3 (160)	7.9 (202)	1.6 (42)	2.4 (60)	3.3 (86)	.70 (18)	2.3 (58)	M4	1.5 (38)	-	-	-	M4	.25 x .37 (6.4 x 9.4)
13-PDB-010-12-A															.25 x .37 (6.4 x 9.5)
13-PDB-020-12-B								3.5 (90)	M6	2.3 (58)	-	2.9 (74)	1.9 (49)	M6	.25 x .38 (6.4 x 9.6)
13-PDB-035-12-B	9.6 (243)	8.7 (220)	10.3 (261)	2.3 (58)	2.7 (70)	3.9 (100)	.98 (25)								.25 x .38 (6.4 x 9.7)
13-PDB-050-12-B															.25 x .38 (6.4 x 9.8)
13-PDB-080-13-C					6.1 (155)	7.3 (185)	1.2 (30)		M8	2.4 (62)	M4	3.3 (86)	2.2 (56)	M8	.25 x .39 (6.4 x 9.9)
13-PDB-100-14-C	13.9 (354)	12.6 (320)	15.1 (384)	2.5 (66)				.25 x .36 (6.4 x 9.10)							
13-PDB-150-14-C								.25 x .36 (6.4 x 9.11)							
13-PDB-200-14-D					7.5 (190)	8.6 (220)	1.4 (35)	3.9 (100)							

Common Mode

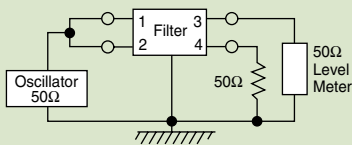

13-PDB-005;-010;-020;-035

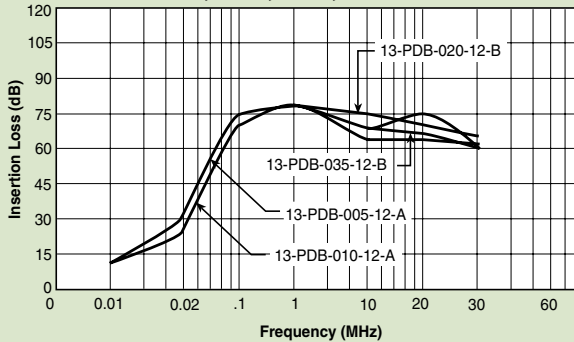

13-PDB-050;-080;-100;-150;-200

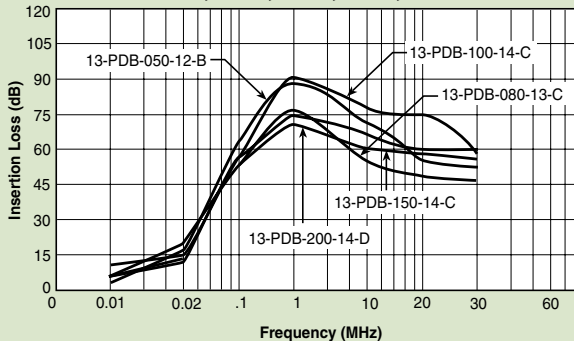

Normal Mode

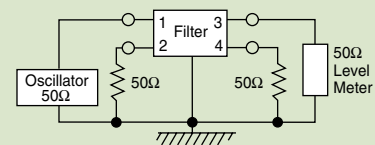

13-PDB-005;-010;-020;-035

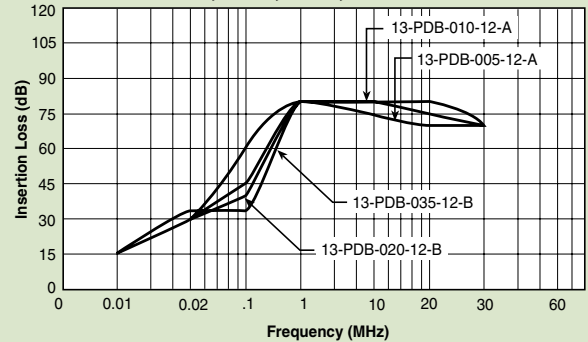

13-PDB-050;-080;-100;-150;-200

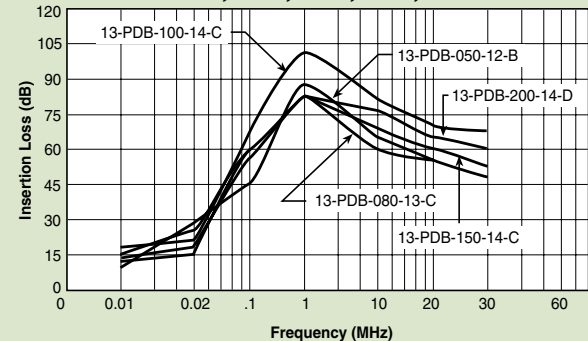

Commercial-Off-The-Shelf (COTS) Filters

API Technologies' Spectrum Control brand now offers COTS single line feed-through EMI filters that are the commercial equivalent to M15733-PRF/72, M15733-PRF/73 and M15733-PRF/74. These reliable AC and DC high performance filters provide an excellent source of filtering in a compact package and are well suited for the military and aerospace industries. They filter up to 500 A with an attenuation of 40 to 90 dB from 1 MHz to 1 GHz and voltage rating of 130 VDC to 250 VAC. Please reference API mechanical drawing.



Dimensions

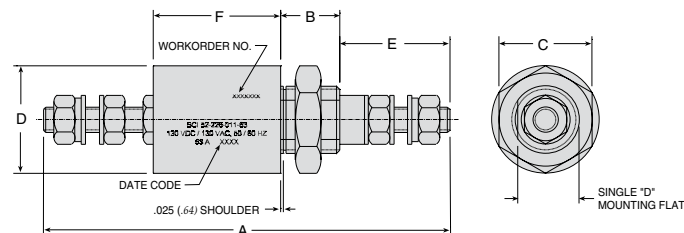

MIL part M15733/	Part Number	A ±0.100	B ±0.032	C ±0.010	D ±0.010	E ±0.100	F Max	Mounting Flat ±0.015
72-0034	5004-7053-100-A	6.750	0.375	0.930	1.500	0.750	4.875	0.656
72-0046	5004-7053-100-A	6.750	0.375	0.930	1.500	0.750	4.875	0.656
72-0043	5004-7053-100-A	6.750	0.375	0.930	1.500	0.750	4.875	0.656
72-0049	5004-7059-100-A	7.250	0.375	0.930	2.000	0.750	5.375	0.656
72-0053	5004-7065-100-A	8.781	0.531	1.625	2.250	1.000	6.250	1.046
73-0034	5004-7058-125-A	7.250	0.375	0.930	2.000	0.750	5.375	0.656
73-0043	5004-7058-125-A	7.250	0.375	0.930	2.000	0.750	5.375	0.656
73-0046	5004-7052-125-A	6.750	0.375	0.930	1.500	0.750	4.875	0.656
73-0049	5004-7058-125-A	7.250	0.375	0.930	2.000	0.750	5.375	0.656
73-0051	5004-7059-250-A	7.250	0.375	0.930	2.000	0.750	5.375	0.656
73-0053	5004-7064-125-A	8.781	0.531	1.625	2.250	1.000	6.250	1.046
74-0030	5004-7041-250-A	4.750	0.310	0.616	1.000	0.600	3.400	0.437
74-0036	5004-7047-250-A	6.500	0.310	0.616	1.000	0.750	4.750	0.473
74-0042	5004-7053-250-A	6.750	0.375	0.930	1.500	0.750	4.875	0.656
74-0045	5004-7059-250-A	7.250	0.375	0.930	2.000	0.750	5.375	0.656

Shielded Filters

API has developed a new MRI filter product line which provides MRI/RF shielding solutions for medical, commercial and government applications. Offers 100 dB insertion loss per MIL-STD 220 from 14 KHZ to 10 GHZ.

Shielded Room Filters

P/N Series	Configuration*	Description
52-1490	1 x 5	1 x 5 A, 277 VAC
	1 x 30	1 x 30 A, 277 VAC
	1 x 100	1 x 100 A, 277 VAC
	1 x 150	1 x 150 A, 277 VAC
	1 x 200	1 x 200 A, 277 VAC
	1 x 225	1 x 225 A, 277 VAC
	2 x 0.5	Speaker Filter
	2 x 1 ALRM	Fire Alarm Filter
	2 x 5	2 x 5 A, 277 VAC
	2 x 20	2 x 20 A, 277 VAC
	2 x 30	2 x 30 A, 277 VAC
	2 x 50	2 x 50 A, 277 VAC
	2 x 60	2 x 60 A, 277 VAC

* Add to P/N series (eg. 52-1490-1x5)

Options are available with or without discharge light "L" at the end of the part (52-1490-1x5L). Custom configurations are available. Consult factory.



Military/Aerospace Multisection Filters

API Technologies' Spectrum Control brand will address virtually any requirement for a military/custom power product. Our engineering expertise and vertical integrations reduce your speed to market as well as saves you money. Our electromagnetic compatibility expertise in the tempest arena can help you meet MIL-F-15733 and MIL-STD 461 standard requirements.

Features

- High common and differential mode attenuation
- Standard designs up to 400 Amps
- Excellent insertion loss characteristics up to 10 GHz
- Voltage rating 115-250VAC and 400VDC up to 400 Hz
- Available to meet TEMPEST and FCC requirements
- Custom designs for application-specific requirements

Test Specifications

The high performance power line filters shown on pages 59 and 60 are designed to meet the following criteria.

The information shown can be used as a basis for filter specifications. (Contact factory for additional details).



Applications

- Military
- Commercial and military/aerospace
- Secured communications
- Switching power supplies
- Data processing equipment
- Ruggedized computers
- Radar
- Electronic warfare
- Ground/air weapon systems
- Satellites
- Ship board systems
- Land based vehicles
- Fixed and mobile control stations

Test Group	Order of Test	Examination or Test	Test Method (Per MIL-STD-202)	Post Test Requirements
IIA	1	Voltage Drop	Paragraph 4.6.8 of MIL-F-15733	Three percent of rated voltage max.
	2	Leakage Current	UL 1283	Per applicable specification
	3	Temperature Rise	MIL-F-15733 Paragraph 4.6.4	25°C max.
	4	Terminal Strength	Method 211, Condition A	No evidence of loosening or rupture. 5 lb. applied force. Line Cords: 35 Lbs.
IIB	1	Shock, Medium Impact	Method 213, Condition G	Must pass DWV and Insertion Loss
	2	Vibration, High Frequency	Method 204, Condition A	Monitor for shorts or open
	3	Thermal Shock	Method 107, Test Condition A	Pass 90% DWV IR to be 30% of initial
	4	Humidity	Method 107, Condition B, except temperature equals 25°C	Pass 90% DWV IR to be 30% of initial
III	1	Life	Method 108, Condition D 1.2 x Rated AC voltage at max. operating temp. or 1.4 x DC voltage	Pass 90% DWV insulation resistance to be 30% of initial.

Military/Aerospace Multisection Filters

Insertion Loss

52-600-001

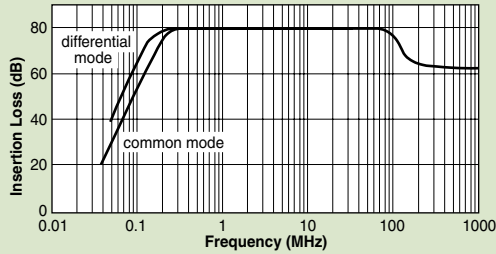

52-600-002

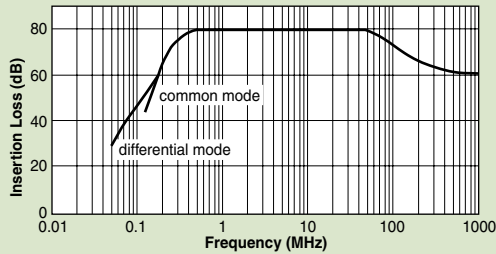

Circuit Schematic

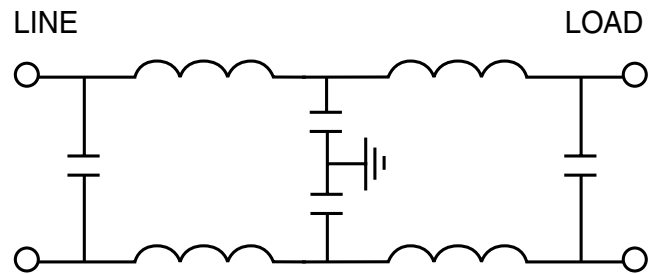

Dimensions

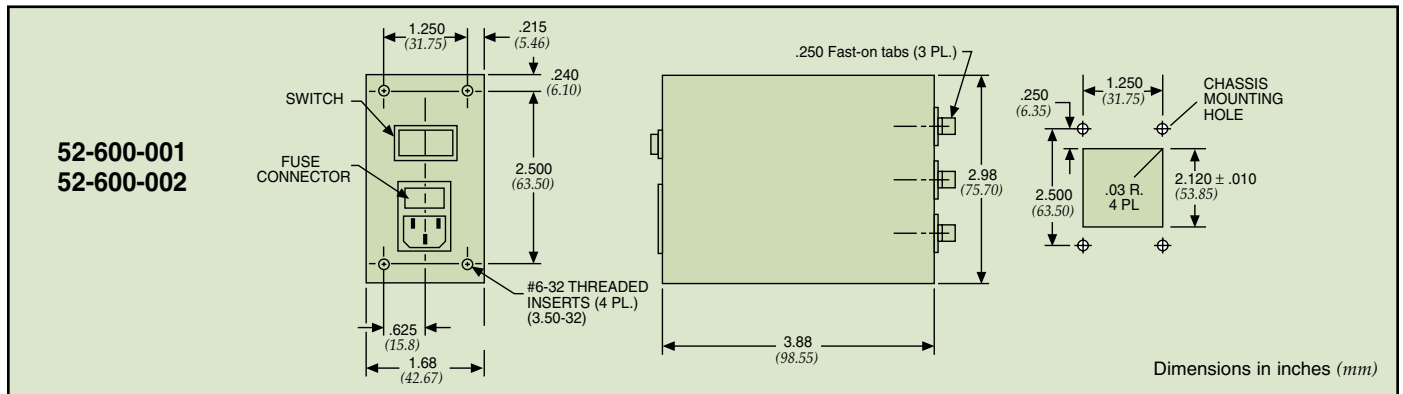

Model	Current Rating	Voltage Rating	Temperature Rating	DCR. max. (ohms)	Leakage Current (max.)	Mode (max.)	Minimum Insertion Loss (db) Per MIL-STD-220						
							50K	150K	300K	1M	10M	100M	1G
52-600-001	5A	120/240VAC 60 Hz	-40°C to +65°C	.20	1 mA	COMM	33	65	80	80	80	80	60
							DIFF	37	65	80	80	80	-
52-600-002	10A	120/240VAC 60 Hz	-40°C to +65°C	.10	1 mA	COMM		-	50	70	80	80	70
							DIFF	25	50	75	80	80	-

Consult factory for UL/CSA approval availability.

Military/Aerospace Multisection Filters

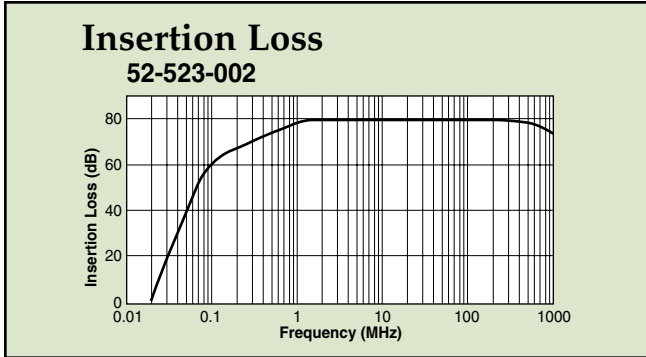

Circuit Schematic

52-523-002

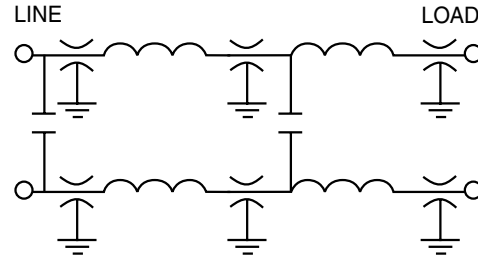

Dimensions

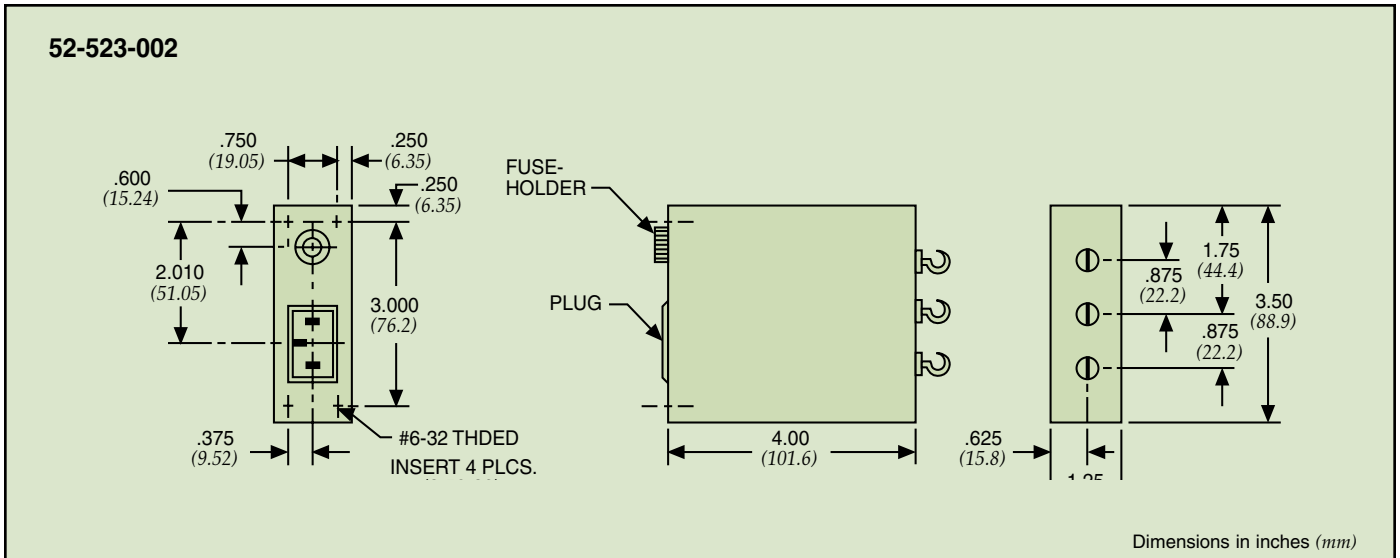

Model	Current Rating	Voltage Rating	Temperature Rating	DCR max. (ohms)	Leakage Current (max.)	Mode (max.)	Minimum Insertion Loss (db) Per MIL-STD-220						
							50K	150K	300K	1M	10M	100M	1G
52-523-002	5A	120/240VAC 60 Hz	-40°C to +65°C	.25	1 mA	COMM	-	55	60	80	80	70	60
							-	50	60	80	80	-	-

Consult factory for UL/CSA approval availability.

Military/Aerospace Multisection Filters

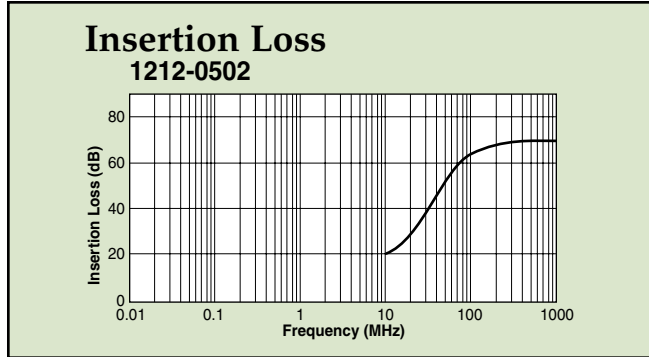
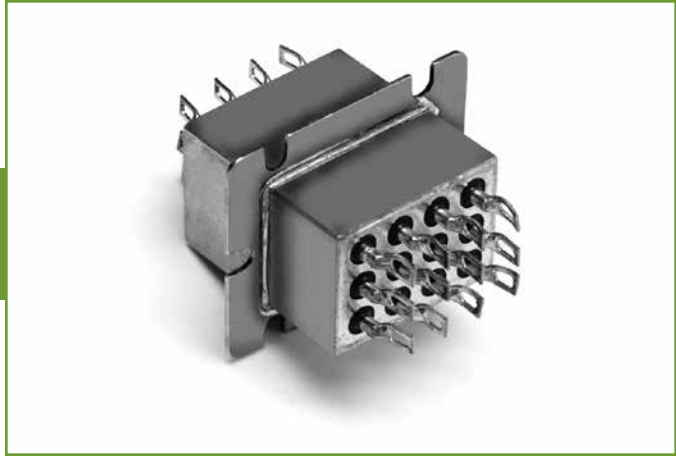

Circuit Schematic

1212-0502

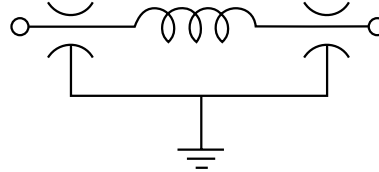

Dimensions

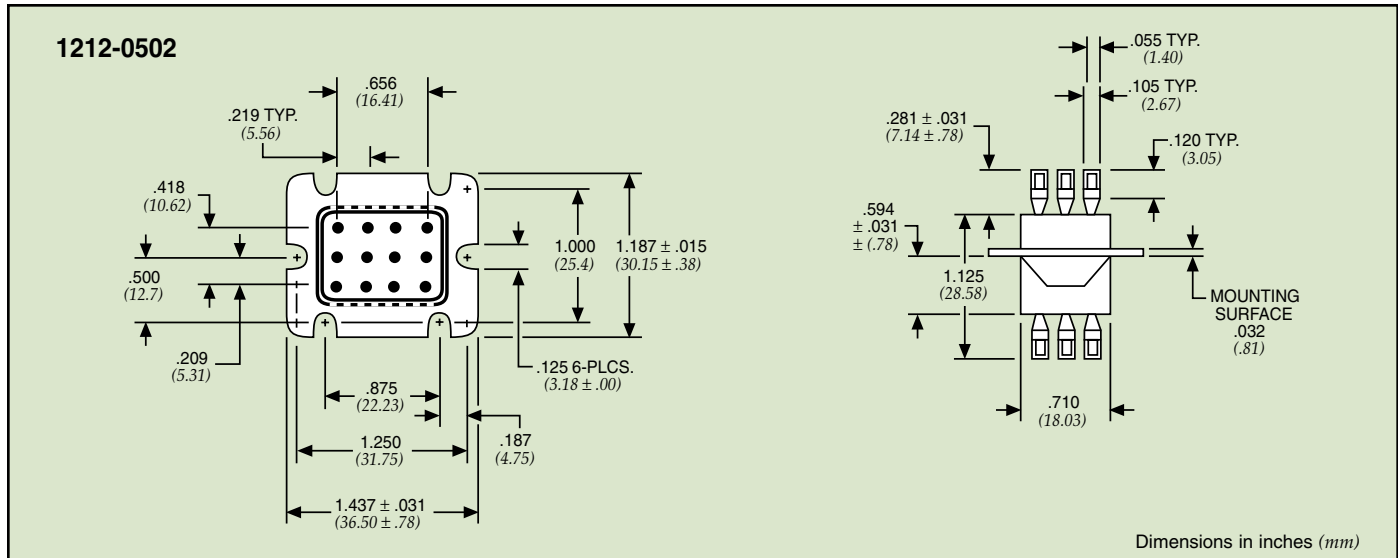

Model	Current Rating	Voltage Rating	Temperature Rating	DCR max. (ohms)	Leakage Current (max.)	C _x Value	Minimum Insertion Loss (db) Per MIL-STD-220			
							10M	100M	500M	1G
1212-0502	10A	350VDC 240VAC 60 Hz	-55°C to +125°C	.01	1 mA	5000pF	20	65	70	70

Consult factory for UL/CSA approval availability.

Military/Aerospace Multisection Filters

Secure Communications

API's electromagnetic compatibility expertise in the secure communication or "TEMPEST" arena is represented by this group of high performance filters. These units are especially well suited for use in MIL-STD-461 applications to reduce conducted emissions. The filters are manufactured with glass sealed terminals and connectors.

Features

- Excellent insertion loss profile
- Available for DC & AC applications up to 400 Hz
- Available for 3-14 Amp applications
- Custom systems can be designed to your specific needs



Filter Schematic A

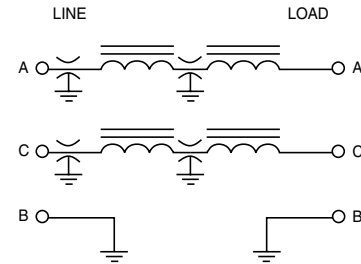

Filter Schematic B

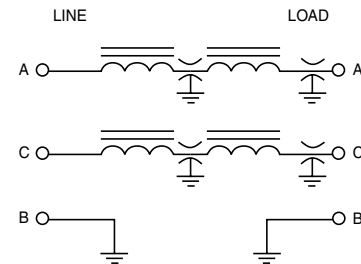

Dimensions

52-378-002

Dimensions in inches (mm)

#8-32 UNC THD. INSERTS (4.17-32)
.350 DEEP, 2 PLACES (8.89)

CONNECTOR #8001-14S-7P-A3
MATES WITH MS-3106-14S-7S

Insertion Loss

52-378-002, -004 MIL-STD-220

Model	Current Rating	Voltage Rating	Temperature Range	DCR max. (ohms)	Leakage Current (max.)	Schematic	Minimum Insertion Loss (db)						
							50 KHz	150 KHz	300 KHz	1 MHz	10 MHz	100 MHz	1 GHz
52-378-001	3 Amps	240VAC 60 Hz Line to Line	-55°C to 85°C	.3	50 mA	A	30	60	70	80	80	70	70
52-378-002	5 Amps	240VAC 60 Hz Line to Line	-55°C to 85°C	.2	50 mA	B	24	64	70	80	80	70	70
52-378-004	5 Amps	240VAC 60 Hz Line to Line	-55°C to 85°C	.2	50 mA	A	34	64	70	80	80	70	70
52-378-005	3 Amps	240VAC 60 Hz Line to Line	-55°C to 85°C	.3	50 mA	B	40	70	80	80	80	70	60

Military/Aerospace Multisection Filters

Insertion Loss

52-387-010, -003 MIL-STD-220
52-409-001 MIL-STD-220

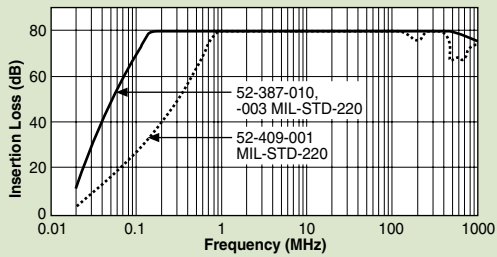

Filter Schematic C

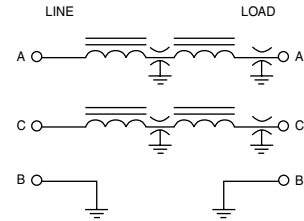

Filter Schematic D

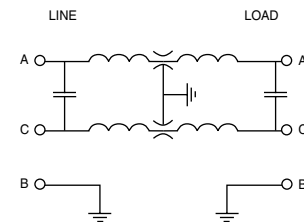

Filter Schematic E

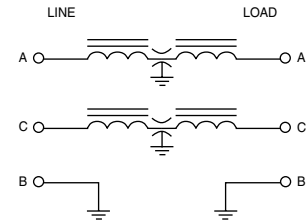

3 Phase and 400 Hz models available.
Please consult the factory.

Dimensions

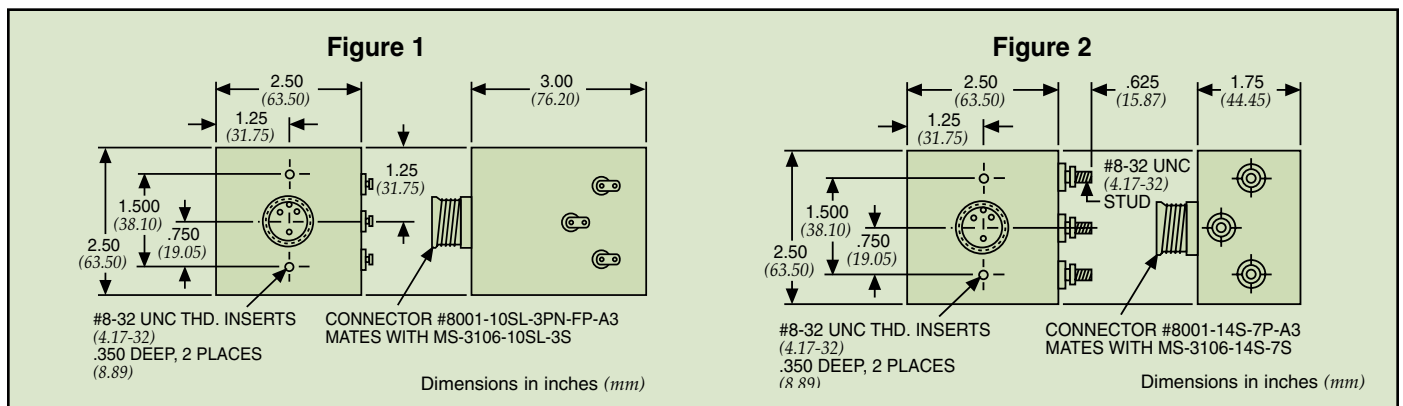

Model	Fig.	Current Rating	Voltage Rating	Temperature Range	DCR max. (ohms)	Leakage Current (max.)	Sch.	Mode	Minimum Insertion Loss (db)						
									50 KHz	150 KHz	300 KHz	1.0 MHz	10 MHz	100 MHz	1 GHz
52-387-010 70	1	10 Amps	240VAC 60 Hz Line to Line	-55°C to 85°C	.2	50 mA	C	common	24	60	70	80	80	70	
52-387-012	1	5 Amps	240VAC 400 Hz Line to Line	-55°C to 85°C	.2	5 mA	D	common	34	64	70	80	80	70	70
								differential	30	30	70	80	80	-	-
52-409-001 60	2	14 Amps	240VAC 60 Hz Line to Line	-55°C to 85°C	.04	50 mA	E	common	14	30	45	80	80	70	

Military/Aerospace Multisection Filters

Secure Communications

Features

- Meets applicable sections of MIL-F-15733
- Excellent performance
- Integral IEC connector
- Available with integral fused IEC connector and two pole switch
- Current ratings to 15 Amps
- Custom designs available

Electrical Specifications

Rated current ranges 3, 6, 10, 15 Amps

Rated voltage 115-250VAC

Operating frequency 50-60 Hz

Maximum leakage current

 @ 115VAC 60 Hz 1.2 mA

 @ 250VAC 50 Hz 2.5 mA

Test voltage

 Line-to-Line 1450VDC

 Line-to-Ground 2250VDC



Part Numbering System:

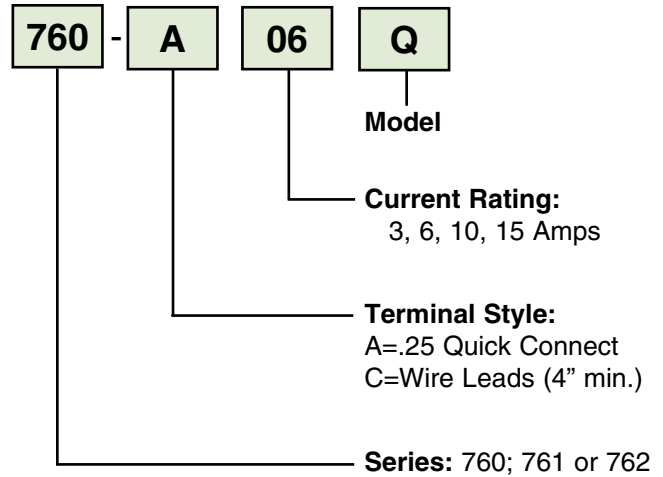

Insertion Loss

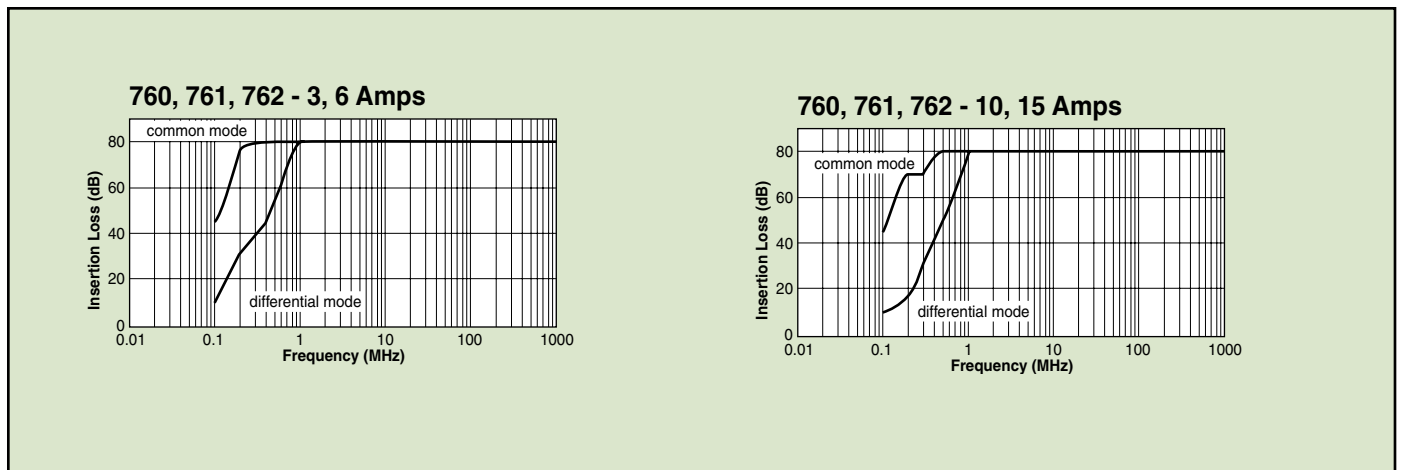

Common Mode (CM) is tested in a 50 ohm system with all lines tied together on the line and load sides of the filter.
Differential Mode (DM) is tested in a 50 ohm system using a 180° phase splitter on both sides of the filter.

Military/Aerospace Multisection Filters

Dimensions - 760 Series

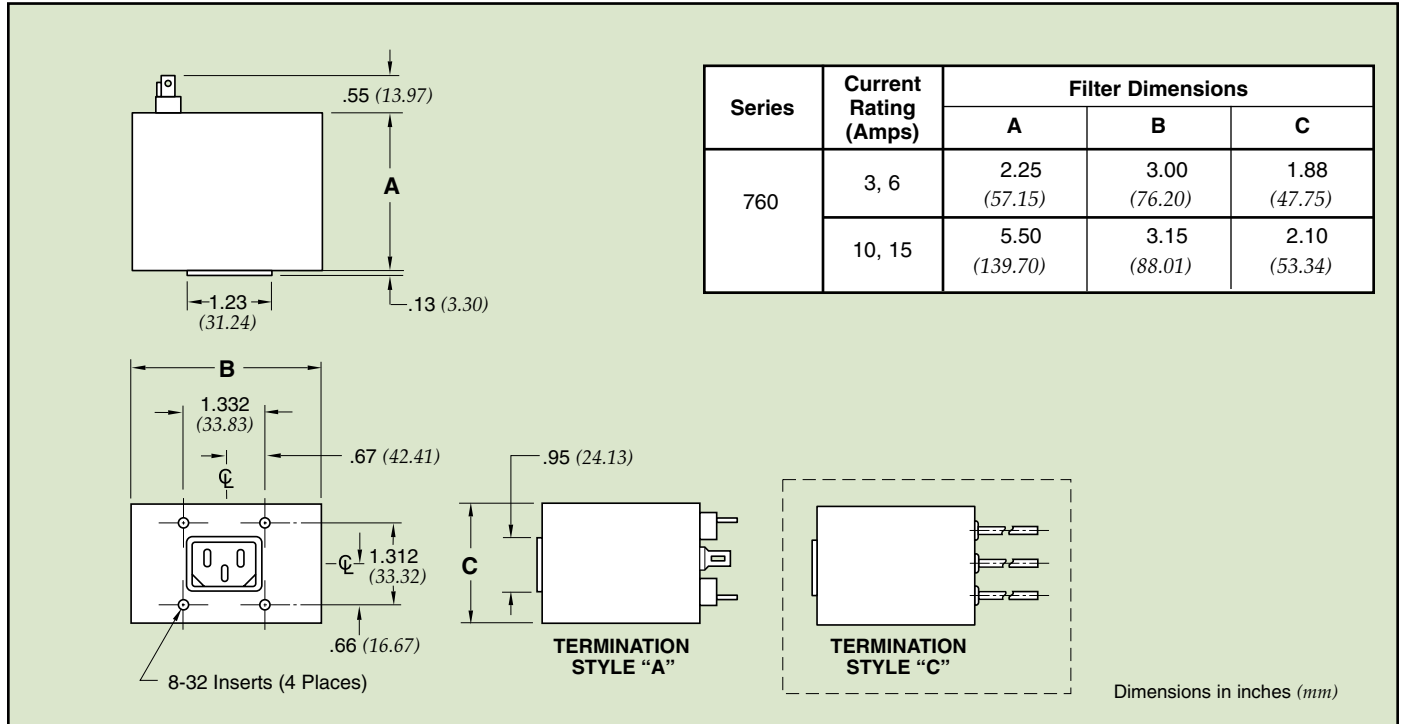

Dimensions - 761, 762 Series

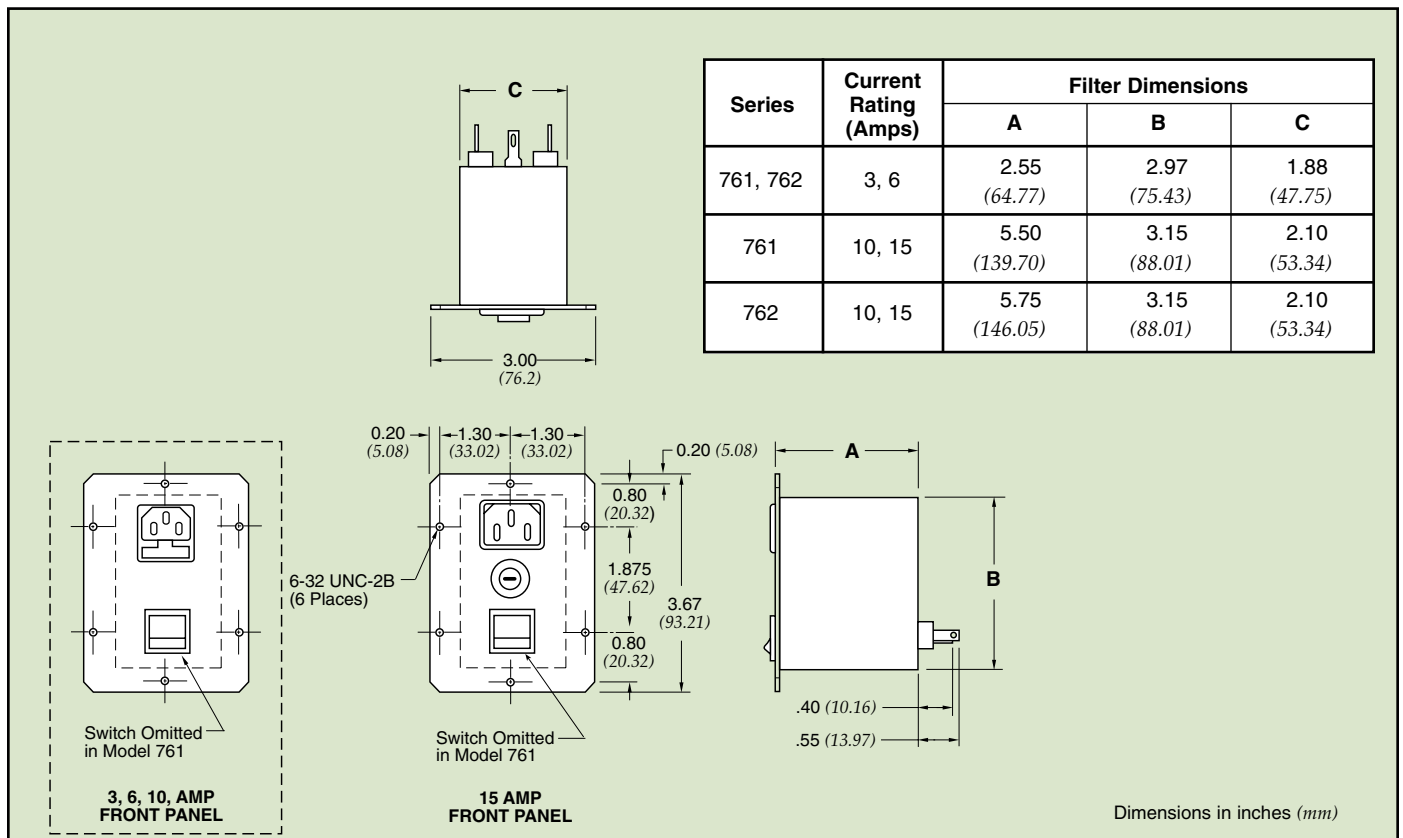

EMI Power Filter Solutions

Military and Aerospace

API Technologies has a long history of partnering with leading suppliers of the defense industry. Our ability to find solutions to suppress or eliminate electromagnetic interference (EMI) allows us to provide the high reliability filters required for military and aerospace applications. API's Spectrum Control brand can design your custom filter with a unique mechanical package for those unusual or tight fitting spaces, higher performance filtering and the voltage rating you need to address all of your AC and DC power issues.

Communications

API's Spectrum line of power filter solutions can create an agency-approved product that will filter and condition the power to your communications infrastructure equipment, as well as eliminate emissions that can contaminate your distributed AC and DC power. Our custom power filters will incorporate all the components and the filtering in one complete package to save you space, time and money. And as a vertically integrated supplier, API offers global low cost manufacturing which allows us to produce fast prototypes and a quicker time to market.

Medical

Our many years of experience in providing EMI/RFI solutions has given us the know-how to design products to meet the specific constraints and requirements of the medical industry. Much of the medical equipment used today requires complete suppression of any and all EMI, as well as low-leakage, nonmagnetic properties to prevent negatively affecting surrounding equipment. We will design and build a high reliability, high performance custom power filter to meet your system and all EN requirements.

Industrial

At API, we do everything from package design and metalworking to EMI filtering to EMC testing, which means a lower cost for you. Our engineers will design and build a custom power filter that will satisfy global EMC regulations, improve speed-to-market times, overcome space constraints and withstand harsh environmental conditions. Our plug-and-play designs cover a range of industrial and instrumentation applications that will address any of your power filtering needs with current ratings as high as 500 Amps.

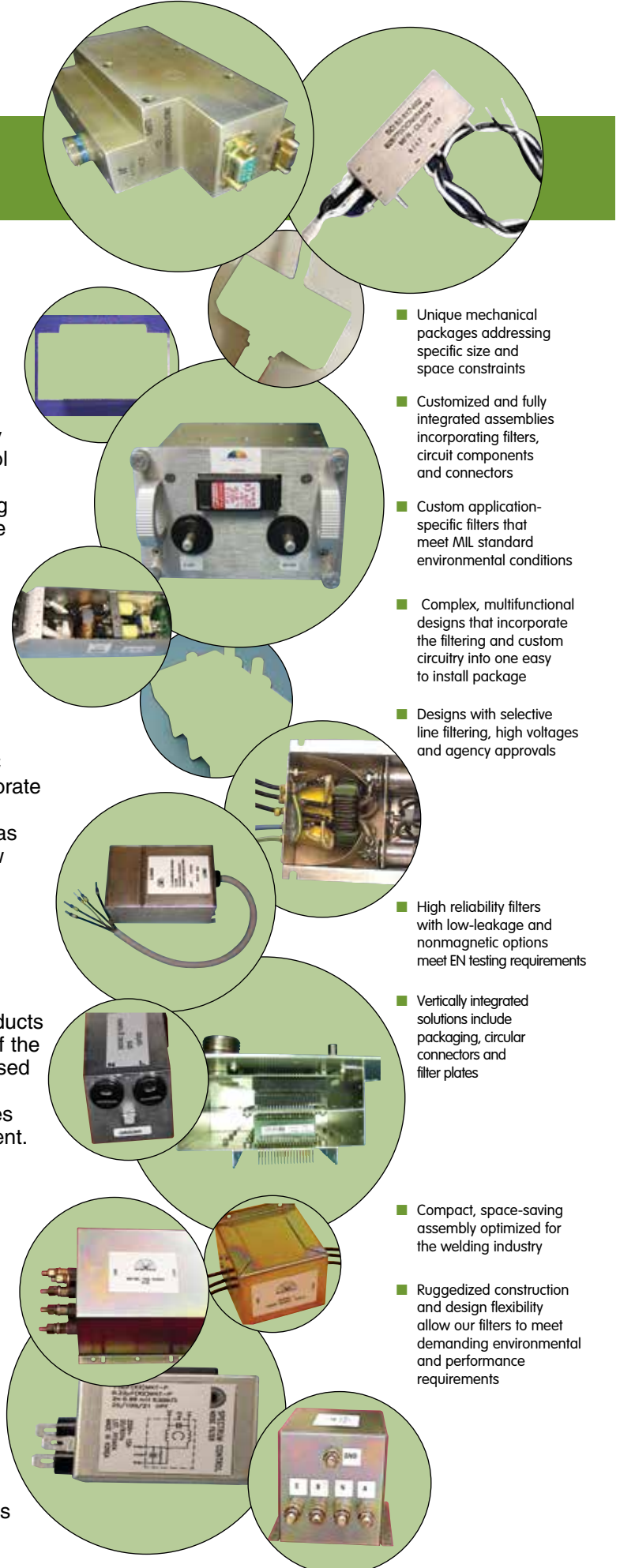

- Unique mechanical packages addressing specific size and space constraints
- Customized and fully integrated assemblies incorporating filters, circuit components and connectors
- Custom application-specific filters that meet MIL standard environmental conditions
- Complex, multifunctional designs that incorporate the filtering and custom circuitry into one easy to install package
- Designs with selective line filtering, high voltages and agency approvals
- High reliability filters with low-leakage and nonmagnetic options meet EN testing requirements
- Vertically integrated solutions include packaging, circular connectors and filter plates
- Compact, space-saving assembly optimized for the welding industry
- Ruggedized construction and design flexibility allow our filters to meet demanding environmental and performance requirements